

FAX UNIT

(Machine Code: A891)

This manual explains the Fax Unit, as well as the following.

- EXFUNC board - Fax Function Expander (Machine Code: A892)
- Handset (Machine Code: A646)
- PCFE board - PC Fax Expander(Machine Code: A894)
- ISDN kit (Machine Code: A890) :Europe model only
- (EXMEM board – Expansion Memory)

May 17th, 1999
Subject to change.

Lithium Batteries

CAUTION

The danger of explosion exists if batteries on the FCU and EXMEM boards are incorrectly replaced.

Replace only with the same or an equivalent type recommended by the manufacturer. Discard used batteries in accordance with the manufacturer's instructions.

CE 0682 X

The interface complies with the requirements for Council Decision 98/482/EC.

98/482/EC:

Council Decision of 20 July 1998 on a common technical Regulation for the requirements for connection to the analogue public switched telephone networks (PSTNs) of terminal equipment (excluding terminal equipment supporting the voice telephony justified case service) in which network addressing, if provided, is by means of dual tone multi-frequency (DTMF) signaling.

Network compatibility declaration for the EU.

Fax Option Type 185 is designed to work on all EU networks.

TABLE OF CONTENTS

| | |
|--|------------|
| 1. OVERALL MACHINE INFORMATION | 1-1 |
| 1.1 SPECIFICATIONS | 1-1 |
| 1.2 FEATURES..... | 1-2 |
| 1.2.1 FEATURES LIST | 1-2 |
| 1.2.2 CAPABILITIES OF PROGRAMMABLE ITEMS | 1-5 |
| 1.3 OVERALL MACHINE CONTROL | 1-6 |
| 1.3.1 SYSTEM CONTROL..... | 1-6 |
| 1.3.2 POWER DISTRIBUTION AND CONTROL | 1-7 |
| 1.3.3 MEMORY BACK-UP | 1-7 |
| 1.4 VIDEO DATA PATH | 1-8 |
| 1.4.1 TRANSMISSION..... | 1-8 |
| 1.4.2 RECEPTION | 1-10 |
| 1.4.3 PC FAX COMMUNICATION | 1-11 |
| 1.4.4 SCANNING AND PRINTING | 1-13 |
| 2. DETAILED SECTION DESCRIPTIONS..... | 2-1 |
| 2.1 AUTOMATIC SERVICE CALLS..... | 2-1 |
| 2.1.1 SERVICE CALL CONDITIONS..... | 2-1 |
| 2.1.2 PERIODIC SERVICE CALL..... | 2-3 |
| 2.1.3 PM CALL | 2-3 |
| 2.1.4 EFFECTIVE TERM OF SERVICE CALLS | 2-3 |
| 2.2 SCANNING FEATURES..... | 2-4 |
| 2.2.1 PAGE SPLIT TRANSMISSION (BOOK TRANSMISSION)..... | 2-4 |
| 2.2.2 IMAGE ROTATION BEFORE TRANSMISSION | 2-5 |
| 2.3 PRINTING FEATURES..... | 2-7 |
| 2.3.1 PAPER SIZE SELECTION | 2-7 |
| 2.3.2 JUST SIZE PRINTING | 2-13 |
| 2.4 FAX COMMUNICATION FEATURES..... | 2-14 |
| 2.4.1 SEP/SUB/PWD/SID | 2-14 |
| 2.4.2 JBIG COMPRESSION | 2-16 |
| 2.4.3 V.8/V.34 PROTOCOL | 2-17 |
| 2.5 LINE TYPE CHANGE | 2-20 |
| 2.6 PCBS..... | 2-21 |
| 2.6.1 FCU | 2-21 |
| 2.6.2 NCU (US)..... | 2-23 |
| 2.6.3 NCU (EUROPE/ASIA) | 2-24 |
| 2.6.4 EXFUNC BOARD | 2-25 |
| 3. INSTALLATION..... | 3-1 |
| 3.1 FAX UNIT | 3-1 |
| 3.2 EXFUNC BOARD (FAX FUNCTION UPGRADE)..... | 3-10 |
| 3.3 PCFE UNIT (PC-FAX EXPANDER UPGRADE) | 3-12 |
| 3.4 HANDSET (USA MODELS ONLY) | 3-15 |
| 3.5 EXMEM BOARD (EXPANSION MEMORY)..... | 3-16 |

| | |
|--|------------|
| 4. SERVICE TABLES | 4-1 |
| 4.1 SERVICE LEVEL FUNCTIONS | 4-1 |
| 4.1.1 HOW TO ENTER AND EXIT THE FAX SERVICE MODE | 4-1 |
| 4.1.2 BIT SWITCH PROGRAMMING (FUNCTION 01)..... | 4-1 |
| 4.1.3 SYSTEM PARAMETER LISTS (FUNCTION 02) | 4-2 |
| 4.1.4 FCU ROM VERSION DISPLAY (FUNCTION 02) | 4-4 |
| 4.1.5 MODEM PROGRAM VERSION DISPLAY (FUNCTION 02)..... | 4-4 |
| 4.1.6 ERROR CODE DISPLAY (FUNCTION 03)..... | 4-4 |
| 4.1.7 SERVICE MONITOR REPORT (FUNCTION 04)..... | 4-4 |
| 4.1.8 G3 PROTOCOL DUMP LIST (FUNCTION 05) | 4-5 |
| 4.1.9 G4 PROTOCOL DUMP LIST (FUNCTION 05) | 4-5 |
| 4.1.10 RAM DISPLAY AND REWRITE (FUNCTION 06) | 4-6 |
| 4.1.11 NCU PARAMETERS (FUNCTION 06)..... | 4-6 |
| 4.1.12 RAM DUMP (FUNCTION 06)..... | 4-7 |
| 4.1.13 RAM CLEAR (FUNCTION 07) | 4-7 |
| 4.1.14 FCU REBOOT | 4-7 |
| 4.1.15 SERVICE STATION FAX NUMBER (FUNCTION 09) | 4-8 |
| 4.1.16 SERIAL NUMBER (FUNCTION 10)..... | 4-8 |
| 4.1.17 MODEM TEST (FUNCTION 11) | 4-8 |
| 4.1.18 V.34 MODEM TEST (FUNCTION 11)..... | 4-9 |
| 4.1.19 DTMF TEST (FUNCTION 11)..... | 4-9 |
| 4.1.20 RINGER TEST (FUNCTION 11)..... | 4-10 |
| 4.1.21 MEMORY TEST (FUNCTION 11)..... | 4-10 |
| 4.1.22 FILE PRINTOUT (FUNCTION 13) | 4-11 |
| 4.1.23 JOURNAL PRINTOUT (FUNCTION 14) | 4-11 |
| 4.1.24 USAGE LOG PRINTOUT (FUNCTION 15)..... | 4-11 |
| 4.1.25 DATA TRANSFER (FUNCTION 16) | 4-12 |
| 4.2 BIT SWITCHES | 4-13 |
| 4.2.1 SYSTEM SWITCHES | 4-13 |
| 4.2.2 SCANNER SWITCHES | 4-27 |
| 4.2.3 PRINTER SWITCHES | 4-32 |
| 4.2.4 COMMUNICATION SWITCHES | 4-37 |
| 4.2.5 G3 SWITCHES | 4-44 |
| 4.3 NCU PARAMETERS | 4-53 |
| 4.4 DEDICATED TRANSMISSION PARAMETERS | 4-63 |
| 4.4.1 PROGRAMMING PROCEDURE | 4-63 |
| 4.4.2 PARAMETERS | 4-64 |
| 4.5 SERVICE RAM ADDRESSES | 4-68 |
| | |
| 5. PREVENTIVE MAINTENANCE | 5-1 |
| 5.1 SPECIAL TOOLS AND LUBRICANTS | 5-1 |
| 5.2 PM TABLE | 5-1 |
| | |
| 6. REMOVAL AND REPLACEMENT | 6-1 |
| 6.1 PRECAUTION | 6-1 |
| 6.2 NCU AND SPEAKER..... | 6-1 |
| 6.3 FCU | 6-2 |
| 6.3.1 REMOVAL | 6-2 |

| | | |
|-----------|--|------------|
| 6.3.2 | SRAM DATA RESTORE FROM FCU..... | 6-2 |
| 6.3.3 | SRAM DATA RESTORE FROM FLASH CARD BACKUP | 6-4 |
| 6.4 | FIRMWARE UPDATE..... | 6-6 |
| 6.4.1 | FCU FIRMWARE DOWNLOAD | 6-6 |
| 6.4.2 | FCU ROM UPLOAD | 6-8 |
| 6.5 | SRAM DATA BACKUP AND RESTORE | 6-10 |
| 6.5.1 | SRAM BACKUP TO A FLASH MEMORY CARD..... | 6-10 |
| 6.5.2 | SRAM RESTORE FROM A FLASH MEMORY CARD..... | 6-11 |
| 7. | TROUBLESHOOTING..... | 7-1 |
| 7.1 | ERROR CODES | 7-1 |
| 7.2 | FAX SC CODES | 7-10 |
| 7.2.1 | OVERVIEW | 7-10 |
| 7.2.2 | SC1201 | 7-10 |
| 7.2.3 | SC1207 | 7-10 |
| 7.2.4 | FAX SC CODE TABLE | 7-11 |

1. OVERALL MACHINE INFORMATION

1.1 SPECIFICATIONS

Type

Desktop type transceiver

Circuit

PSTN, PABX, ISDN (Europe model only)

Connection

Direct couple

Original Size (Book)

Maximum Length: 432 mm [17 ins]

Maximum Width: 297 mm [11.7 ins]

Original Size (ADF)

Length: 128 - 1200 mm [5.0 – 47.2 ins]

Width: 105 - 297 mm [4.1 - 11.7 ins]

Thickness: 40 - 128 g/m² [10 - 34 lbs]

Scanning Method

Flat bed, with CCD

Scan Width

210 mm [8.3 ins] ± 1% (A4)

216 mm [8.5 ins] ± 1% (8.5" x 11")

256 mm [10.1 ins] ± 1% (B4)

279 mm [11.0 ins] ± 1% (11" x 17")

297 mm [11.7 ins] ± 1% (A3)

Resolutions

8 x 3.85 lines/mm (G3 only)

8 x 7.7 lines/mm (G3 only)

8 x 15.4 lines/mm (G3 only)

16 x 15.4 lines/mm (G3 only)

200 x 100 dpi

200 x 200 dpi

400 x 400 dpi

Note:

To use the 8 x 15.4 lines/mm, 16 x 15.4 lines/mm and 400 x 400 dpi resolutions, an optional EXMEM is required.

Memory Capacity

ECM: 128 Kbytes

SAF:

Standard: 2 Mbytes (160 pages)

With optional memory board (EXFUNC + EXMEM) :

30 Mbytes (3000 pages)

Measured using an ITU-T #1 test document (Slerexe letter)

Compression

MH, MR, MMR

JBIG (EXFUNC is required, G3/IG3 only)
(MMR only with ECM and G4)

SAF storage for memory tx: MMR and/or raw data

Protocol

Group 3 with ECM

Group 4 (ISDN unit required)

Modulation

V.34, V.33, V.17 (TCM), V.29 (QAM),

V.27ter (PHM), V.8, V.21 (FM)

Data Rate (bps)

G3:

33600/31200/28800/26400/24000/21600/
19200/16800/14400/12000/9600/7200/4800
/2400, Automatic fallback

G4 (option): 64 kbps/56 kbps

I/O Rate

With ECM: 0 ms/line

Without ECM: 2.5, 5, 10, 20, or 40 ms/line

Transmission Time

G3: 3 s at 28800 bps; Measured with G3 ECM using memory for an ITU-T #1 test document (Slerexe letter) at 8 x 3.85 l/mm resolution

G4 (option): 3 s at 64 kbps; Measured with an ITU-T #1 test document (Slerexe letter) at 200 x 200 dpi resolution

1.2 FEATURES

1.2.1 FEATURES LIST

KEY:

O = Used, X = Not Used,
 (A = Optional EXMEM required)
 B = Optional EXFUNC required
 C = Optional PCFE required
 D = Optional ISDN unit required
 (only available in the Europe)

| Video Processing Features | |
|--|---|
| Automatic image density selection | O |
| Contrast | O |
| Halftone (Basic & Error Diffusion) | O |
| JBIG compression | B |
| MTF | O |
| Reduction before tx | O |
| Scanning Resolution – Standard | O |
| Scanning Resolution – Detail | O |
| Scanning Resolution – Fine | A |
| Scanning Resolution – Superfine | A |
| Smoothing to 400 x 400 dpi when printing | O |

| Communication Features – Automatic | |
|--------------------------------------|---|
| Automatic fallback | O |
| Automatic redialing (Memory tx only) | O |
| Dual Access | O |
| Length Reduction | O |
| Resolutions available for reception | |
| Detail | O |
| Fine | A |
| Superfine | A |
| Substitute reception | O |
| V34 communication | O |

| Communication Features - User Selectable | |
|--|---|
| 90° Image Rotation before tx | O |
| Action as a transfer broadcaster | X |
| AI Redial (last ten numbers) | O |
| Answering machine interface | X |
| Authorized Reception | O |
| Auto Document | O |
| Automatic dialing (pulse or DTMF) | O |
| Automatic Voice Message | X |
| Batch Transmission | O |
| Book Original tx | O |
| Broadcasting | O |
| Chain Dialing | O |
| Communication Record Display | O |
| Confidential ID Override | O |
| Confidential Reception | O |
| Confidential Transmission | O |
| Direct Fax Number Entry | O |
| Economy Transmission | O |
| Fax on demand | X |
| Forwarding | O |
| Free Polling | O |
| Groups (Standard: 9 groups) | O |
| Hold | X |
| ID Transmission | O |
| Immediate Redialing | O |
| Immediate Transmission | O |
| ISDN | D |
| Keystroke Programs | O |
| Memory transmission | O |
| Multi-step Transfer | X |
| Non-standard original size transmission | O |
| OMR | X |
| On Hook Dial | O |
| Ordering Toner | X |
| Page Count | O |
| Page separation mark | O |
| Parallel memory transmission | O |
| Partial Image Area Scanning | X |

| Communication Features - User Selectable | |
|---|---|
| Personal Codes | O |
| Personal Codes with Conf. ID | X |
| Polling Reception | O |
| Polling Transmission | O |
| Polling tx file lifetime in the SAF | O |
| Quick Dial (Standard: 32 stations) | O |
| Reception modes (Fax, Tel) | O |
| Remote control features | X |
| Remote Transfer | X |
| Restricted Access | O |
| Secured Polling | O |
| Secured Polling with Stored ID Override | O |
| Send Later | O |
| SEP/SUB/PWD/SID | O |
| Silent ringing detection | X |
| Specified Image area | X |
| Speed Dial (Standard: 100 stations) | O |
| Stamp | O |
| Telephone Directory | O |
| Tonal Signal Transmission | O |
| Transfer Request | O |
| Transmission Deadline (TRD) | O |
| Turnaround Polling | X |
| Two in one | O |
| Voice Request (immed. tx only) | X |

| Communication Features - Service Selectable | |
|--|---|
| AI Short Protocol | O |
| Auto-reduction override option | O |
| Busy tone detection | O |
| Cable Equalizer | O |
| Closed Network | O |
| Continuous Polling Reception | O |
| Dedicated tx parameters | O |
| ECM | O |
| EFC | X |
| Inch-mm conversion before tx | O |
| Length Reduction | O |
| Page retransmission times | O |

| Communication Features - Service Selectable | |
|--|---|
| Protection against wrong connection | O |
| Short Preamble | X |

| Other User Features | |
|-----------------------------------|---------|
| Area code prefix | X |
| Center mark | O |
| Checkered mark | O |
| Clearing a memory file | O |
| Clearing a polling file | O |
| Clock | O |
| Confidential ID | O |
| Counters | O |
| Daylight Saving Time | O |
| Destination Check | X |
| Direct entry of names | O |
| Energy Saver | O |
| File Retention Time | O |
| File Retransmission | O |
| Function Programs (F1 – F4) | O |
| Hard Disk Filing System | X |
| ID Code | O |
| Label Insertion ("To xxx") | O |
| Language Selection | SP mode |
| Memory Lock | X |
| Modifying a memory file (tx) | O |
| Multi Sort Document Reception | X |
| Own telephone number | O |
| Print density control | X |
| RDS on/off | O |
| Reception Mode Switching Timer | X |
| Reception time printing | O |
| Remaining memory indicator | O |
| Reverse Order Printing | O |
| RTI, TTI, CSI | O |
| Service Report Transmission | O |
| Speaker volume control | O |
| Specified Cassette Selection | O |
| Substitute reception on/off | O |
| Telephone line type | O |
| Toner Saving Mode | X |
| TTI/CIL on/off | O |

| Other User Features | |
|-----------------------------|---|
| User Function Keys (4 keys) | O |
| User Parameters | O |
| Wild Cards | O |

| Reports - Automatic | |
|------------------------------|---|
| Charge Control Report | X |
| Communication Failure Report | O |
| Confidential File Report | O |
| Error Report | O |
| Fax On Demand Report | X |
| File Clear Report | O |
| File Reserve Report | O |
| Journal | O |
| Polling Result Report | O |
| Power Failure Report | O |
| Transfer Result Report | X |
| Transmission Result Report | O |

| Reports - User-initiated | |
|-----------------------------------|---|
| Authorized Reception List | O |
| Charge Control Report | X |
| File List | O |
| Forwarding List | O |
| Group List | O |
| Hard Disk File List | X |
| Journal | O |
| Personal Code List | O |
| Program List | O |
| Quick Dial Label | O |
| Quick Dial List | O |
| Specified Cassette Selection List | X |
| Speed Dial List | O |
| Transmission Status Report | X |
| User Function List | X |
| User Parameter List | O |

| Service Mode Features | |
|-------------------------|---------|
| Back-to-back test | O |
| Bit switch programming | O |
| Cable equalizer | O |
| Comm. parameter display | O |
| Counter check | SP mode |

| Service Mode Features | |
|---|---------|
| Country code | O |
| DTMF tone test | O |
| Echo countermeasure | O |
| Effective term of service calls | O |
| Error code display | O |
| Excessive jam alarm | O |
| File Transfer (all files) | O |
| LCD contrast adjustment | SP mode |
| Line error mark | X |
| Memory file printout (all files) | O |
| Modem Software Download | X |
| Modem test (include V.34 / V.8) | O |
| NCU parameters | O |
| Periodic service call | O |
| PM Call | O |
| Printing all communication records kept in memory | O |
| Protocol dump list | O |
| RAM display/rewrite | O |
| RAM dump | O |
| RAM test | O |
| RDS | |
| - RAM read/write | O |
| - Dial data transfer (Quick/Speed) | O |
| - Software transfer | O |
| Ringer test | O |
| ROM version display (FCU) | SP mode |
| Serial number | O |
| Service monitor report | O |
| Service station number | O |
| Software Upload/Download | O |
| SRAM data backup/restore | O |
| System parameter list | O |
| Technical data on the Journal | O |

1.2.2 CAPABILITIES OF PROGRAMMABLE ITEMS

The following table shows how the capabilities of each programmable item will change after the optional function upgrade card is installed.

| Item | Standard | With optional function board (EXFUNC) |
|--|--|--|
| Maximum number of memory files | 200 | 1000 |
| Maximum number of destinations per file | 232 | 500 |
| Maximum number of destinations overall | 300 | 2000 |
| Maximum number of pages overall | 400 | 3000 |
| Number of Quick Dials | 32 | 32 |
| Number of Speed Dials | 100 | 1000 |
| Number of Groups | 9 | 30 |
| Maximum number of destinations per Group | 232 | 500 |
| Maximum number of destinations dialed from the ten-key pad overall | 100 | 1000 |
| Maximum number of programs | 32 (programmed in 32 Quick Dial keys) | 32 (programmed in 32 Quick Dial keys) |
| Maximum number of Auto Documents | 6 (programmed in 6 Quick Dial keys) | 18 (programmed in 18 Quick Dial keys) |
| Maximum number of communication records for the TCR (Journal) stored in the memory | 100 | 900 |
| Maximum number of addresses specified for features such as Authorized Reception and Specified Cassette Selection | 30 | 50 |
| Maximum number of user function keys | 4 | 4 |
| Maximum number of personal codes | 20 | 50 |

1.3 OVERALL MACHINE CONTROL

1.3.1 SYSTEM CONTROL

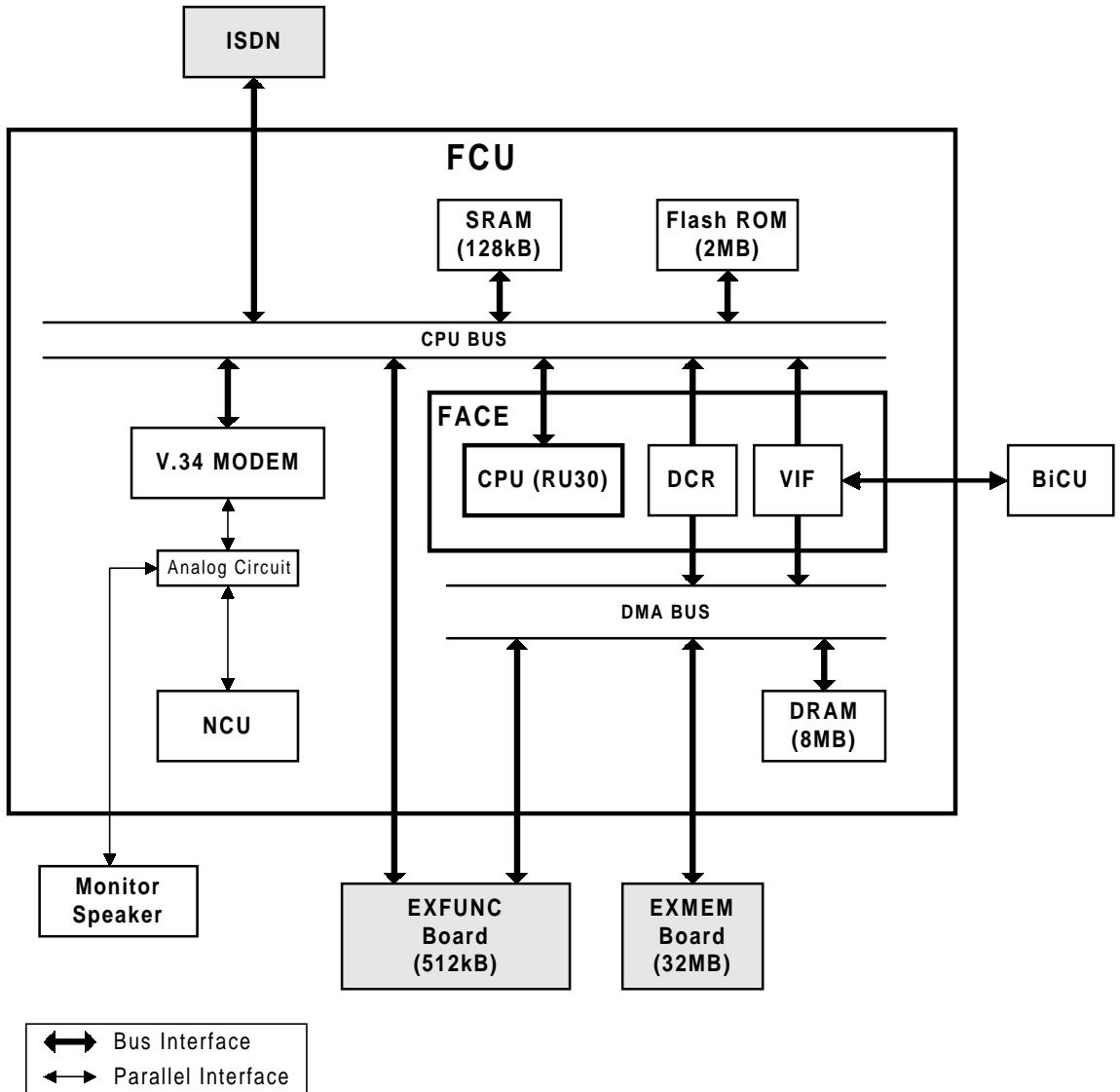

A891V500.WMF

The basic fax unit consists of two PCBs: an FCU and an NCU.

The FCU controls all the fax communications and fax features, in cooperation with the base copier's main board, the BiCU. The NCU switches the analog line between the fax unit and the external telephone.

Fax Options

1. EXFUNC board: JBIG compression becomes available. In addition, this expands the system's SRAM capacity to hold programmed telephone numbers, communication records, etc.
2. PC fax expander: Class 2 fax communication from a PC and local printing from a PC fax application become available (PC fax application required). Also, local scanning from the machine's scanner using TWAIN API becomes available (CFM Twain driver required).
3. ISDN unit (Europe model only): This allows the fax unit to communicate over an ISDN (Integrated Services Digital Network) line.
4. EXMEM board: This expands the SAF memory capacity. Also, this expands the page memory capacity to enable 400 dpi communications.)

1.3.2 POWER DISTRIBUTION AND CONTROL

The FCU power is supplied from the base copier's BiCU (+24V, +12V, -12V, and +5V). Refer to the base copier's service manual for details.

1.3.3 MEMORY BACK-UP

The system parameters and programmed items in the SRAM on the FCU and the EXFUNC board are backed up by batteries (long-term backup), in case the base copier's main switch is turned off.

The SAF memory (DRAM) on the FCU and the EXMEM board are backed up by rechargeable batteries for 1 hour.

1.4 VIDEO DATA PATH

1.4.1 TRANSMISSION

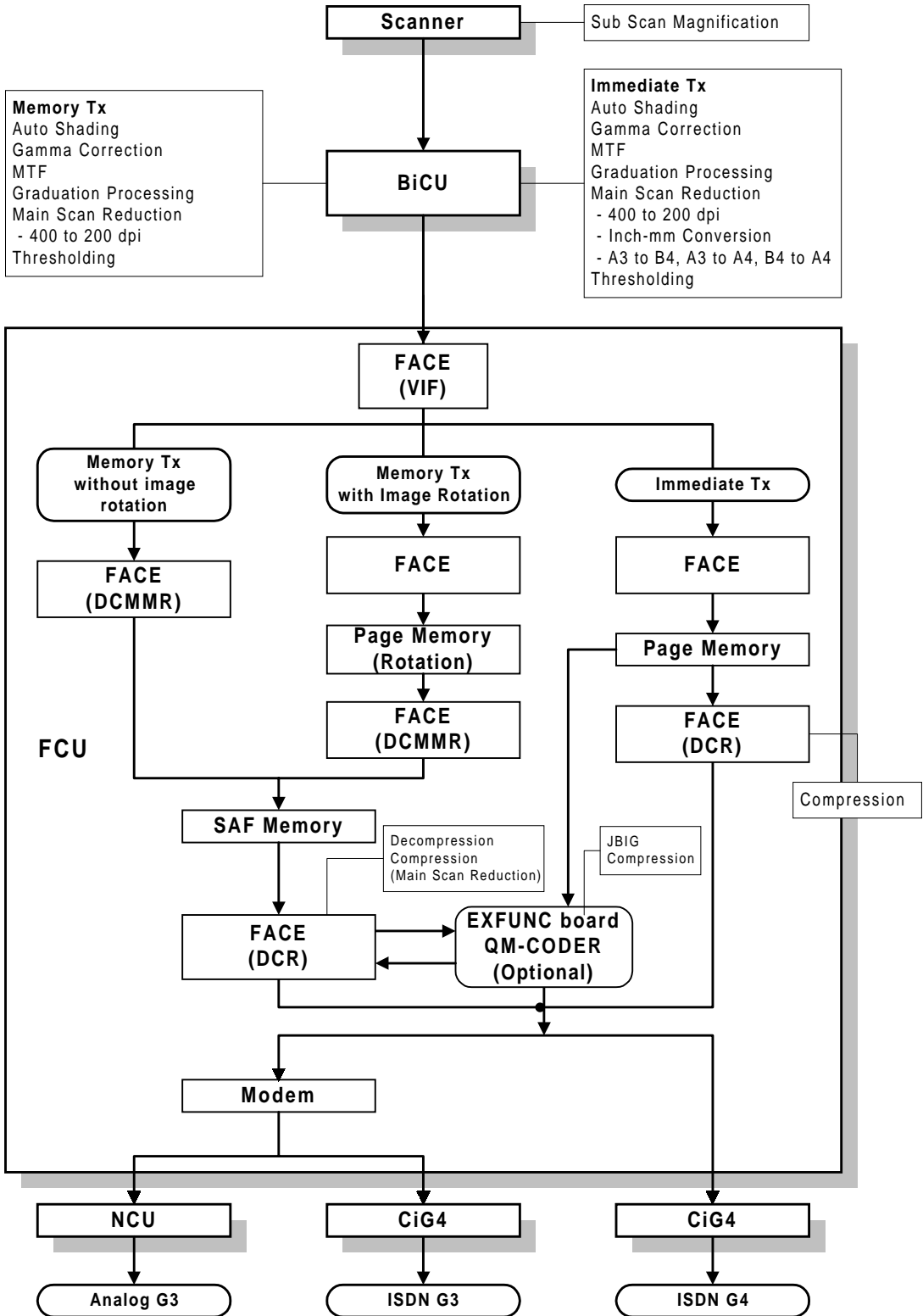

Memory Transmission and Parallel Memory Transmission

The base copier's scanner scans the original at the selected resolution in inch format. The BiCU processes the data and transfers it to the FCU.

NOTE: When scanning a fax original, the BiCU uses the MTF and thresholding parameter settings programmed in the fax unit's scanner bit switches, not the copier's SP modes.

Then, the FCU converts the data to mm format, and compresses the data in MMR or raw format to store it in the SAF memory. If image rotation is possible, the image is rotated in page memory before compression.

At the time of transmission, the FCU decompresses the stored data, then re-compresses and/or reduces the data if necessary for transmission. Either the NCU or CiG4 (optional) transmits the data to the line.

Immediate Transmission

The base copier's scanner scans the original at the resolution agreed with the receiving terminal. The BiCU video processes the data and transfers it to the FCU.

NOTE: When scanning a fax original, the BiCU uses the MTF and thresholding parameter settings programmed in the fax unit's scanner bit switches, not the copier's SP modes.

Then the FCU stores the data in page memory, and compresses the data for transmission. Either the NCU or CiG4 (optional) transmits the data to the line.

JBIG Transmission

- **Memory transmission:** With memory transmission, if the receiver has JBIG compression, the data goes from the FACE (DCR) to the EXFUNC for JBIG compression. Then either the NCU or CiG4 (ISDN G3) transmits the data to the line.
- **Immediate transmission:** With immediate transmission, if the receiver has JBIG compression, the data goes from the page memory to the EXFUNC for JBIG compression. Then either the NCU or CiG4 (ISDN G3) transmits the data to the line.

1.4.2 RECEPTION

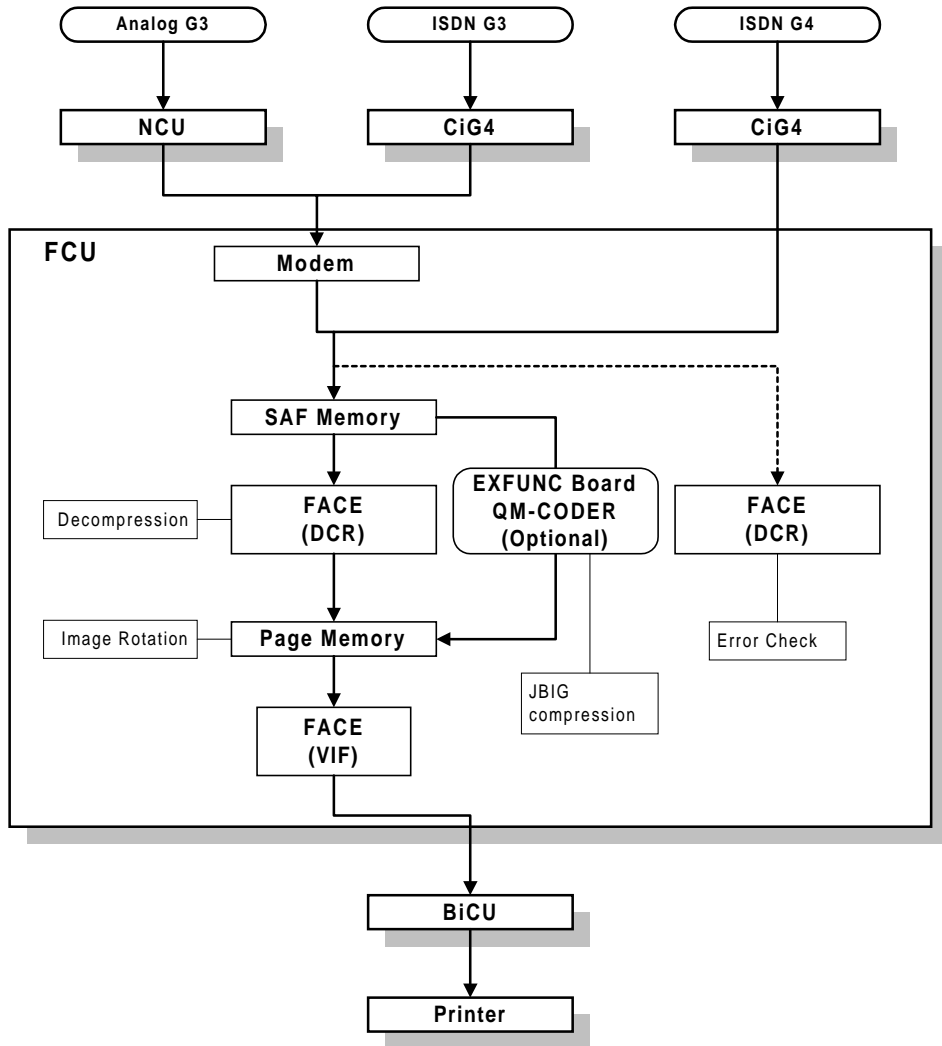

A891V502.WMF

First, the FCU stores the data from either an analog line or an ISDN line to the SAF memory. (The data goes in parallel to the FACE, and is checked for error lines/frames.)

The FCU then decompresses the data and transfers it to page memory. If image rotation is possible, the image is rotated in the page memory. The data is transferred to the BiCU.

JBIG Reception

When the machine receives data compressed with JBIG, the data is sent to EXFUNC for decompression. Then the data is stored in the page memory, and transferred to the BiCU.

1.4.3 PC FAX COMMUNICATION

Direct transmission

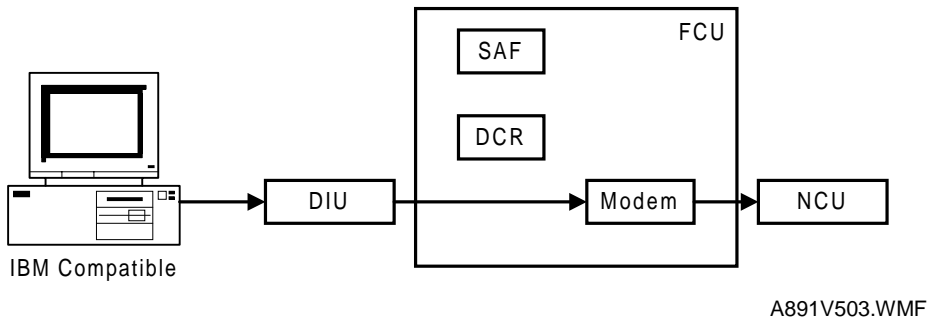

The host computer sends commands and image data to the machine through the DIU during transmission.

- NOTE:**
- 1) Group dials programmed in the machine cannot be used.
 - 2) T.30 optional protocols (e.g., BFT) are not supported by class 2 fax communication.
 - 3) ISDN G4 numbers programmed in quick or speed dials cannot be used. (Only for Europe model)
 - 4) If ISDN is selected for G3 communication (system switch 0A, bit 6), the G3 numbers must have been programmed in quick or speed dial. (Only for Europe model)

Memory transmission

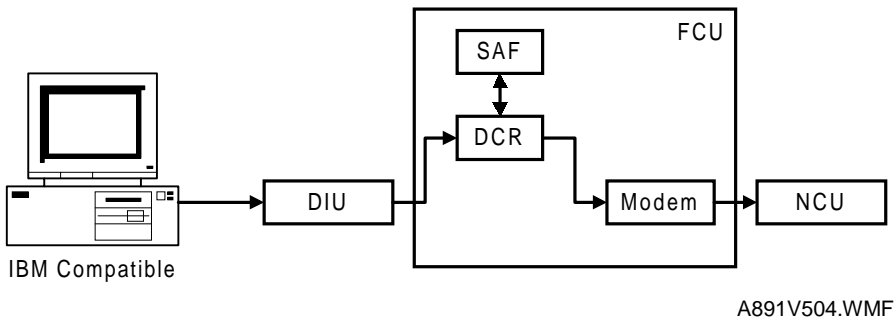

The host computer sends destination number(s) and image data to the machine through the DIU during transmission. The machine stores the image in the SAF memory, then makes a fax transmission.

- NOTE:**
- 1) If the memory overflows while storing the first page into SAF memory, the machine does not start the transmission.
 - 2) If the memory overflows while storing the second or subsequent page into SAF memory, the machine transmits all the successfully stored pages.
 - 3) When fax numbers programmed in the machine's quick or speed dials are specified using the PC fax application, all the specified numbers must have been programmed in the fax machine.
 - 4) T.30 optional protocols (e.g., BFT) are not supported by class 2 fax communication.

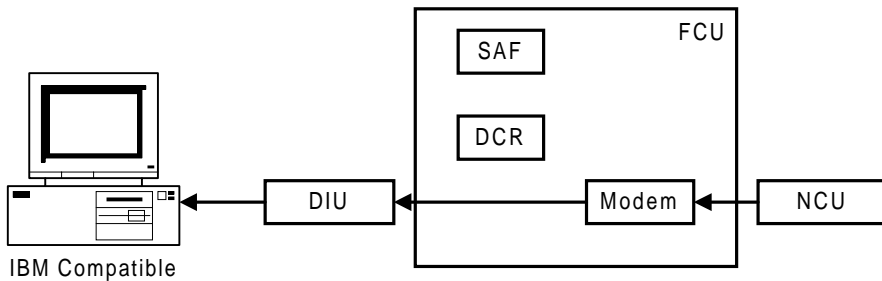
Direct reception

A891V505.WMF

The machine transfers received image data directly to the host PC without storing it into SAF memory.

- NOTE:**
- 1) If the host PC is not ready to receive a fax message, the machine receives the message into SAF memory.
 - 2) Even if the SAF memory is full, the machine starts fax reception. However, the machine will not continue reception if the host computer is not ready to receive a message.
 - 3) The “Number of rings to answer” parameter in the PC fax application must not exceed 4.

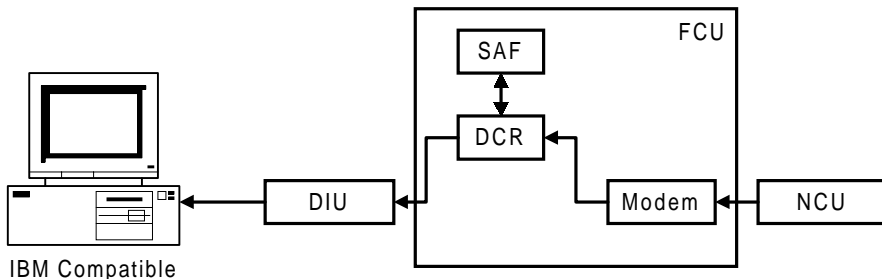
Memory reception

A891V506.WMF

The machine receives a fax message in the SAF memory, then transfers data to the host computer after the reception has finished. The machine prints the received message after transferring data to the host if user parameter 21 – bit 2 is set to “1: Print”.

- NOTE:**
- 1) If an error occurs due to cable disconnection, the PC fax application must be restarted to receive the message.
 - 2) Memory reception is not possible when forwarding is enabled.
 - 3) Manual reception from the PC fax application is not supported.
 - 4) The “Number of rings to answer” parameter in the PC fax application must not exceed 4.

1.4.4 SCANNING AND PRINTING

SCANNING

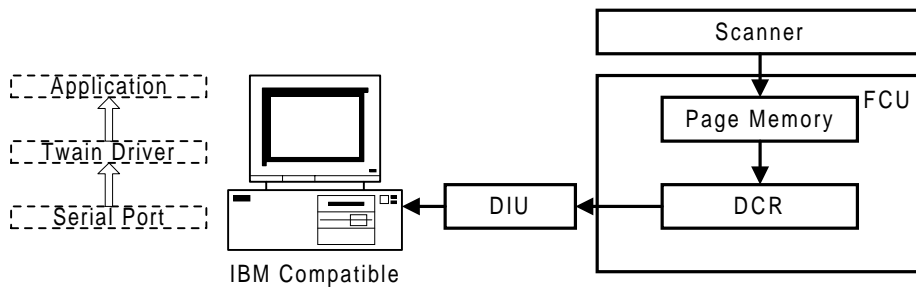

A824D005.WMF

The machine scans an original into page memory, then transfers the data to the host PC. The data is sent to the application through the CFM Twain driver.

NOTE: 1) The maximum resolution is 200 x 200 dpi.

PRINTING

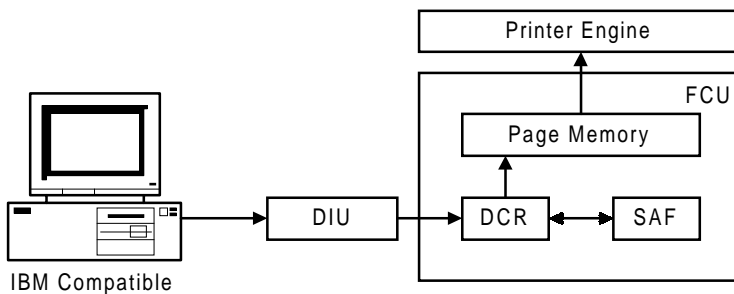

A824D006.WMF

The machine receives print data into SAF memory as fax image data, then prints it after all the data has been transferred from the host PC.

The destination number "0000" informed from the host PC identifies a print job.

- NOTE:**
- 1) If SAF memory runs out while receiving print data, the machine prints up to the successfully received data.
 - 2) The machine cannot receive print data while printing a message from the SAF memory. The data will be received after printing.
 - 3) If a fax destination is specified together with the print destination "0000", the destinations specified after "0000" will be delayed until the machine prints all pages in the message.

2. DETAILED SECTION DESCRIPTIONS

2.1 AUTOMATIC SERVICE CALLS

2.1.1 SERVICE CALL CONDITIONS

The fax unit makes an automatic service call when an SC code other than the codes stored in the following RAM is informed from the base copier's BiCU.

NOTE: The service station's fax number has to be programmed in advance, or the machine cannot make a service call.

Exceptions

| Address (H) | Definition | Default | SC code |
|------------------|--|---------|------------------------------------|
| 680DC8 | 1st SC code - High byte (BCD) | 03 | 329 |
| 680DC9 | 1st SC code - Low byte (BCD) | 29 | Laser beam pitch adjustment error |
| 680DCA | 2nd SC code - High byte (BCD) | 03 | 361 |
| 680DCB | 2nd SC code - Low byte (BCD) | 61 | Hard disk drive error 2 |
| 680DCC | 3rd SC code - High byte (BCD) | 03 | 365 |
| 680DCD | 3rd SC code - Low byte (BCD) | 65 | Image storage address error |
| 680DCE | 4th SC code - High byte (BCD) | 05 | 548 |
| 680DCF | 4th SC code - Low byte (BCD) | 48 | Fusing unit installation error |
| 680DD0 | 5th SC code - High byte (BCD) | 06 | 630 |
| 680DD1 | 5th SC code - Low byte (BCD) | 30 | CSS communication error Japan only |
| 680DD2 | 6th SC code - High byte (BCD) | 09 | 9AA |
| 680DD3 | 6th SC code - Low byte (BCD) | AA | From 900 to 999 |
| 680DD4 to 680DEF | 7th SC code - High byte (BCD) to 20th SC code - Low byte (BCD) | FF(H) | Not Programmed |

To add additional SC codes, program them in the blank addresses.

Wild Cards

This function allows 'A' or 'a', to be used as a wild card instead of numbers from 0 to 9. For example, '1AA' or '1aa' means all the SC codes from 100 to 199, and '39A' or '39a' means all the SC codes from 390 to 399.

The fax unit cannot make an automatic service call when a Fax SC code condition has occurred. Refer to the Troubleshooting section for Fax SC code details.

Manual Service Call

If the service station needs a report, the user can make a service call manually, by changing bit 7 of User Parameter 14 (0E) to '1'.

A sample auto service report

```
* * * Auto Service Report (Date and Time) * * *  
  
ProblemReason of the call - "SC Code" or "PM Call"  
S C Latest 10 copier's SC codes  
J A M BJ A M 2FEED 0000000000
```

Diagram labels:

- Total print counter
- Paper Feed Station
- Jam Location

Service Monitor Report Contents

System Parameter List Contents

2.1.2 PERIODIC SERVICE CALL

The periodic service call notifies the service station of the machine's condition. The call is made at a time interval programmed in the following RAM addresses:

| Parameters | | Address (H) |
|--|---------------------------|---------------|
| Call interval: 01 through 15 months (BCD) 00: Periodic service call disabled | | 6803A1 |
| Date and time of the next call | Day: 01 through 31 (BCD) | 6803A4 |
| | Hour: 01 through 24 (BCD) | 6803A5 |

To change these settings after programming, change the call interval. The machine then automatically changes the remaining parameters by referring to the interval and the current date and time.

2.1.3 PM CALL

If PM alarm is enabled with the base copier's SP mode and PM call is enabled with system switch 01, the machine will make an automatic service call when the base copier's PM counter reaches the PM interval.

Cross reference

- PM service call on/off: System switch 01, bit 0
- PM alarm setting: SP mode 5-912 (default: 80K)

2.1.4 EFFECTIVE TERM OF SERVICE CALLS

If a time limit for the effectiveness of service calls is programmed, the machine stops making automatic service calls after the time limit.

Program the time limit at the following addresses. This function is disabled when all of these addresses are 00(H).

| Parameters | Address (H) |
|--|---------------|
| Year: last two digits of the year (BCD) | 6803AB |
| Month: 01 through 12 (BCD) | 6803AC |
| Day: 01 through 31 (BCD) | 6803AD |

2.2 SCANNING FEATURES

2.2.1 PAGE SPLIT TRANSMISSION (BOOK TRANSMISSION)

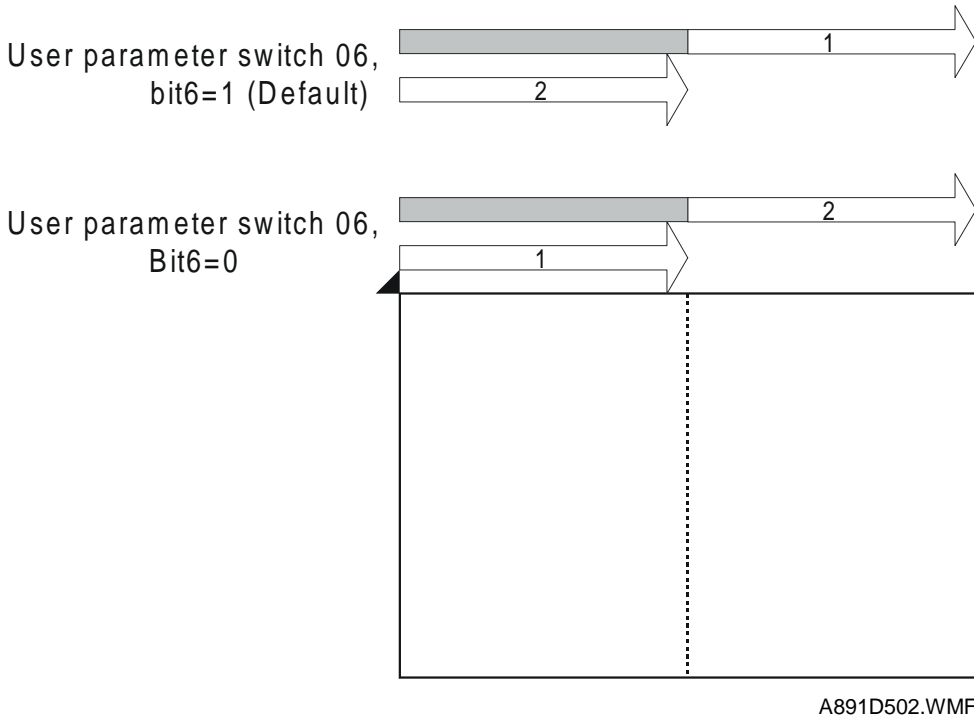

This function allows a B4, A4/8.5 x 11", or A3/11 x 17" size book original to be sent as two separate pages.

When this function is selected, the machine scans the original twice and transmits the pages in the same sequence as they were scanned.

With the default setting, the right page is sent first, then the left page is sent. If the setting is changed, the order is reversed.

Cross Reference

- Scanning start page – User parameter switch 06, bit 6
- Default setting is 1. (Start scan from the right)

- NOTE:**
- 1) This function is only possible when sending a book original from the exposure glass.
 - 2) If this function is used for an A3 or 11 x 17" original, the pages may be transmitted in a lengthwise direction, depending on the setting of "Image Rotation before Transmission" (see the next page).

2.2.2 IMAGE ROTATION BEFORE TRANSMISSION

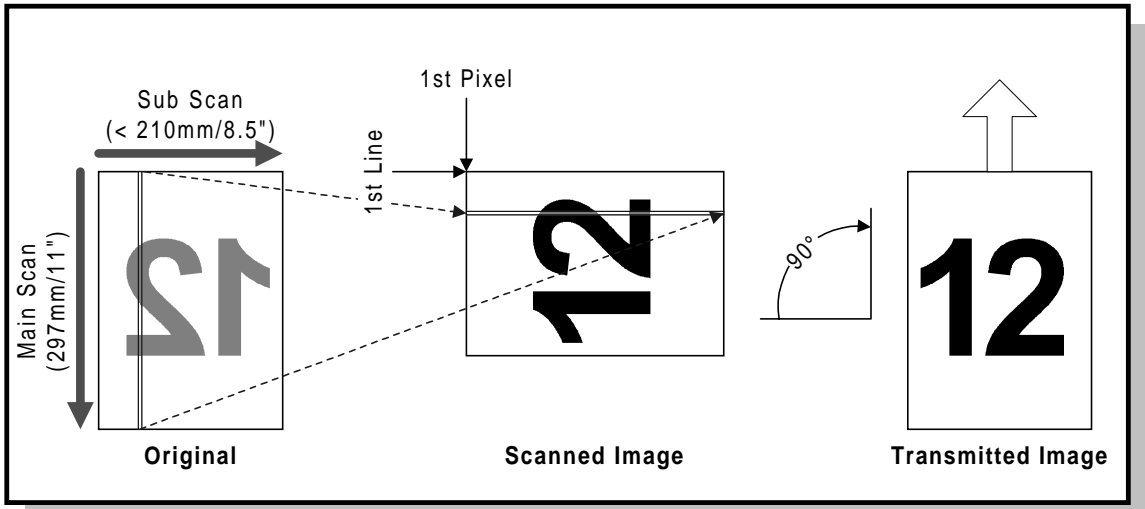

A891D503.WMF

A4 or 8.5 x 11" sideways

This function avoids the unintentional reduction of an A4 or 8.5 x 11" sideways original. When the machine detects a sideways A4 or 8.5 x 11" original in the ADF or on the exposure glass, the fax unit rotates the scanned image clockwise by 90 degrees before transmission, as shown above.

A5 or HLT lengthwise

This function avoids a blank space in the main scan direction. When the machine detects an A5 or HLT original placed lengthwise in the ADF or on the exposure glass, the fax unit rotates the scanned image clockwise by 90 degrees before transmission, as shown above.

- NOTE:**
- 1) Even if Parallel Memory Transmission is enabled, the machine uses normal memory transmission to send an A4 or 8.5 x 11" sideways original.
 - 2) If the machine carries out this function while printing, the machine stops printing until scanning is completed.
 - 3) The machine determines if it will rotate the image after the paper size is determined.
 - 4) This feature is not performed during parallel memory transmission.
 - 5) In Book mode, the machine determines image rotation for each page scanned.
In ADF mode, the machine determines image rotation for the first page. If it is rotated, the machine will check each page. If the first page need not be rotated, the machine will not check the rest of the pages.
 - 6) When this feature is enabled for A5 or HLT lengthwise, 'APS small original detection' must be changed. This allows the machine to detect an A5/HLT size original. With the default setting, the machine does not detect A5 or HLT lengthwise in book mode.

Cross Reference

- Image rotation before Tx A3 or 11" width original on/off
 - Scanner switch 0F, bit 0 (Default setting is enabled)
- Image rotation before Tx A5 or HLT width original on/off
 - Scanner switch 0F, bit 2 (Default setting is disabled)
- Image rotation before Tx B5 width original on/off
 - User Parameter switch 19, bit 3 (Default setting is disabled)
- APS small size original detection
 - Base copier's SP 4-303 (Default setting is "Not detected")
 - Scanner switch 0C, bits 1 and 2
(Default setting is "Depends on the setting of the base copier")

2.3 PRINTING FEATURES

2.3.1 PAPER SIZE SELECTION

This section explains how the FCU selects the appropriate paper size for printing a received fax image.

Width Priority and Length Priority

When 'Width Priority' is selected, a paper size of the same width as the received fax image has a higher priority. The fax image may be printed on several pages.

When 'Length Priority' is selected, a paper size that has enough length to print the received fax image has higher priority. The fax image is printed on one sheet of paper, but the printed fax may have wide margins on the left and right.

Cross Reference

- Paper selection priority - Printer switch 0E, bit 0 (Default: Width)
- Paper size selection priority for an A4 size fax message when A4/LT size paper is not available. - User Parameter switch 16, bit 2
0: A3 has priority (Default setting), 1: B4 has priority

Image Rotation Before Printing

If the machine has the same size paper as the received fax image size, but in sideways orientation, the fax unit rotates the image by 90 degrees clockwise, and prints it sideways.

This feature is only possible when the received fax image is one of the following sizes: A4 lengthwise, 8.5 x 11" lengthwise, B5 lengthwise

NOTE: This function can not be disabled.

Sub-Scan Reduction and Page Separation

Sub-scan Reduction Disabled

When Sub-scan Reduction is disabled, the received fax image is printed unreduced.

If the image is longer than the paper length + 6 mm, the image is separated onto two pages (see the top drawing below).

If the image is shorter than the paper length + 6 mm but longer than the paper length - 4 mm, the part of the image after paper length - 4 mm will be lost (see the bottom drawing below).

NOTE: The page separation threshold is adjustable between 0 and 15 mm (the default is paper length + 6 mm). Refer to Printer Switch 03, bits 4 to 7 for more details.

The 2 mm gaps at the leading and trailing edges depend on the leading and trailing edge margin settings.

The 10 mm image duplication can be adjusted or disabled.

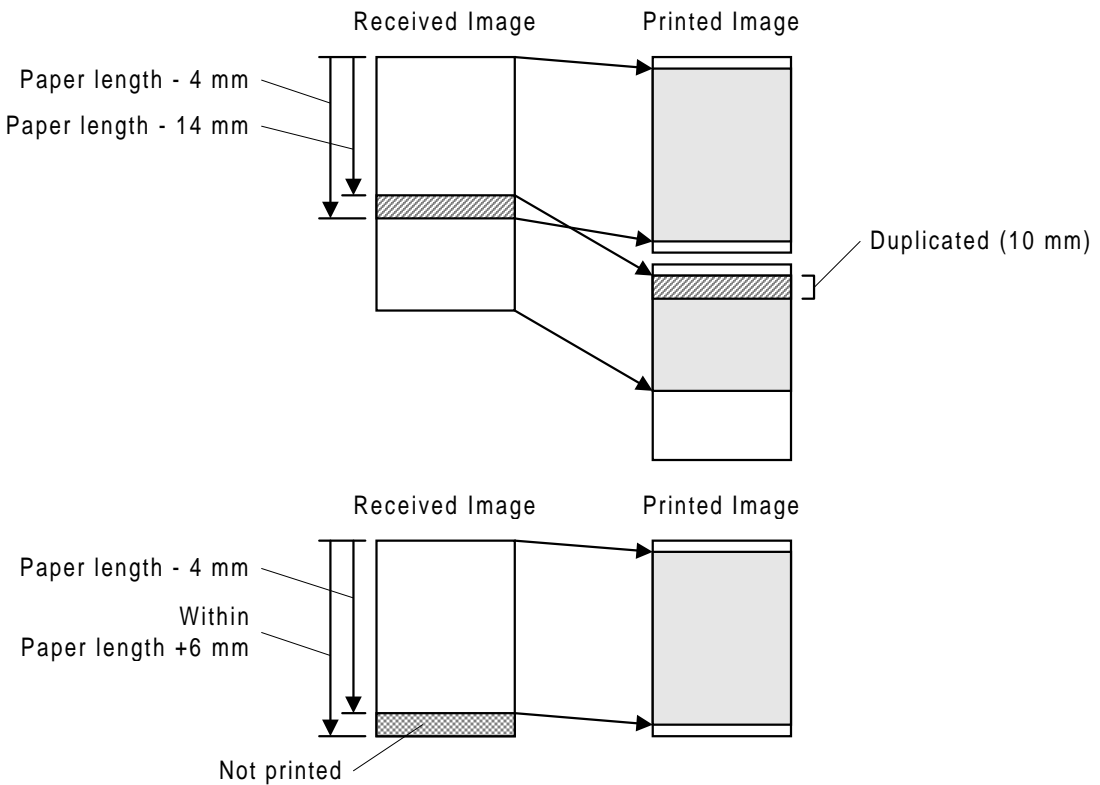

Sub-scan Reduction Enabled

When Sub-scan Reduction is enabled, the received fax image is reduced in the page memory to fit on the selected paper, if the received image length is between [paper length - 4 mm] and [paper length + 20 mm]. See the drawing below.

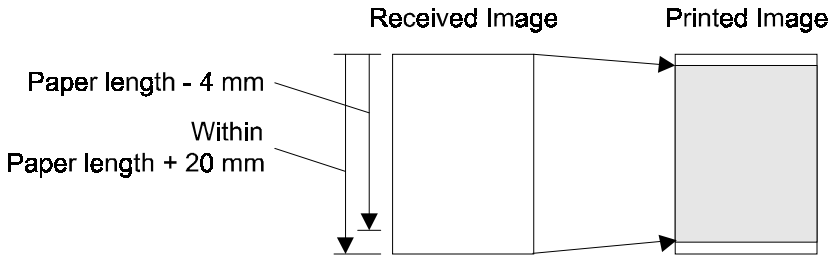

A891D525.WMF

Detailed Descriptions

NOTE: The upper limit (page length + 20 mm) is adjustable between 0 and 155 mm. Refer to Printer Switch 04, bits 0 to 4 for more details.

If the FCU detects that the image must be separated into more than one page after reduction, what happens to the data depends on the Reduction Rate Equalization setting (Printer Switch 0E, bit 7).

- Reduction Rate Equalization Off (Example Diagram: Two-page Printout) -

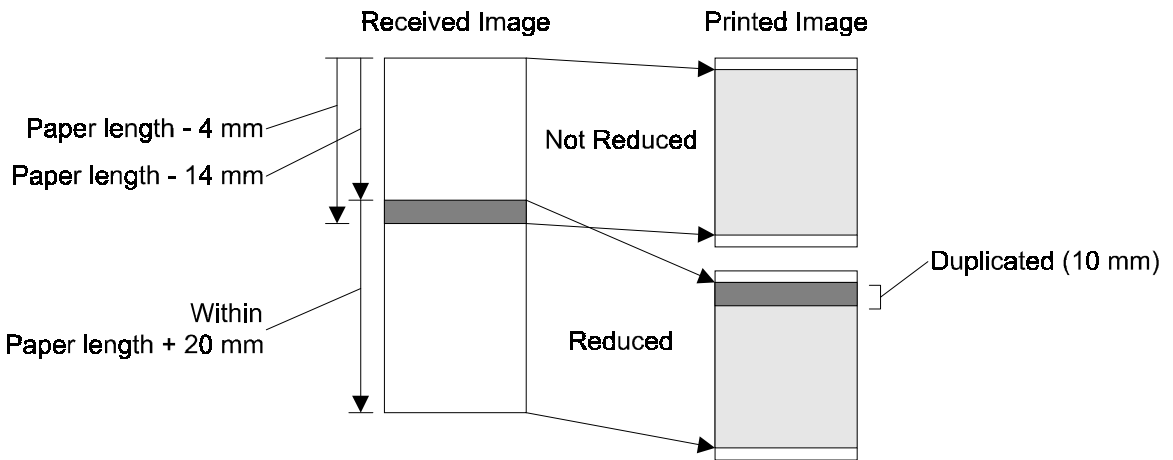

A891D524.WMF

1. The data up to [page length - 4 mm] will be printed on page 1, without reduction.
2. The last 10 mm of this data will be repeated at the top of the next page (this length can be adjusted or repetition can be switched off).
3. The remaining data will be printed on page 2, with reduction, if it is within [paper length + 20 mm].
4. If it is longer than this, page separation is done again. Data up to [page length - 4 mm] will be printed on page 2, without reduction.
5. The process for page 3 and subsequent pages will repeat from step 2.

- Reduction Rate Equalization On (Example Diagram: Two-page Printout) -

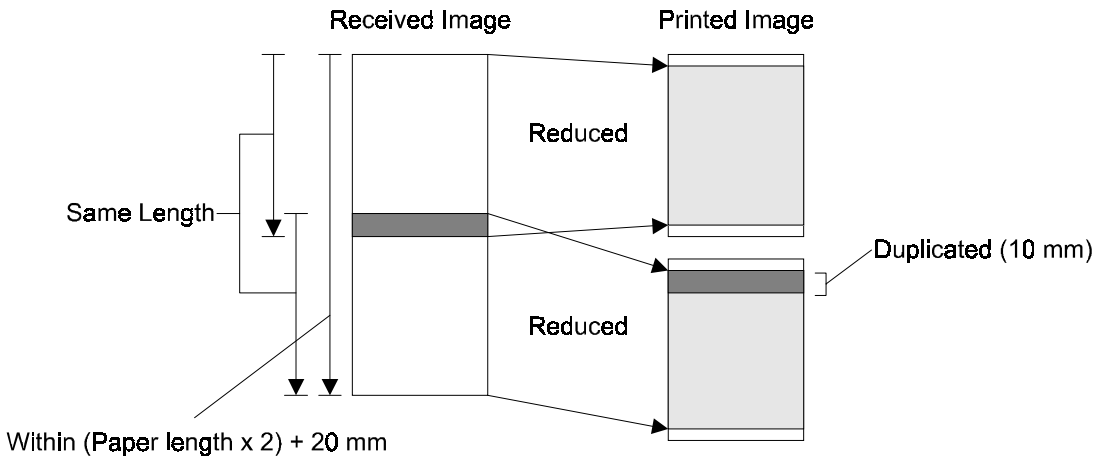

A891D528.WMF

1. The machine determines how many pages will be needed to print the message, taking the following into account:

The final page (n) is such that the received image length is within (paper length x n) + 20 mm

The data must be reduced to fit on pages of length (paper length - 4 mm), with an equal reduction rate for each page.

The last 10 mm of the previous page will be repeated at the top of the next page (this length can be adjusted or repetition can be disabled).

2. The machine prints all the pages, at the same reduction rate.

If the customer does not want to receive a fax message on separate pages, page separation can be disabled. However, once it has been disabled, the machine does not print the received fax message until a paper size which can hold the received fax image on one page is set in a cassette. Keep page separation enabled if the customer expects to receive fax messages longer than the installed paper.

Cross Reference

| Parameter | Switch | Default Setting |
|--|-----------------------------|--------------------------|
| Reduction in sub-scan direction on/off | Printer Switch 03, bit 0 | Enabled (except Germany) |
| Equalizing reduction rate among separated pages | Printer Switch 0E, bit 7 | Enabled |
| Page separation threshold when reduction is disabled | Printer Switch 03, bits 4-7 | 6 mm |
| Page separation threshold when reduction is enabled | Printer Switch 04, bits 0-4 | 20 mm |
| Page separation on/off | Printer Switch 0E, bit 2 | Enabled |
| Page separation mark on/off | Printer Switch 00, bit 0 | Enabled |
| Image duplication with page separation, on/off | Printer Switch 00, bit 1 | Enabled |
| Length of the repeated image on the next page | Printer Switch 04, bits 5-6 | 10 mm |

Page Reduction

This function allows a received fax image to be printed on paper with less width than the fax image.

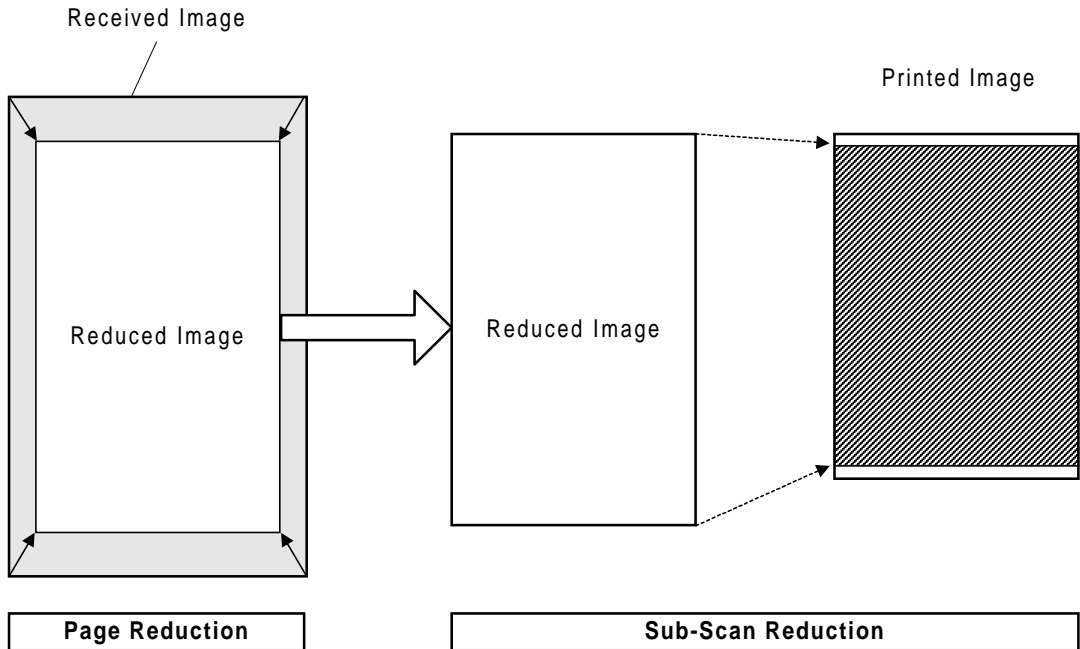

A891D507.WMF

First, the received image is reduced by a fixed reduction rate in the main and sub-scan directions. The available reduction rates are as follows:

- 84% - A3 to B4 reduction
- 82% - B4 to A4 lengthwise reduction

Then, the reduced image is further reduced (if necessary) in the sub-scan direction so that it can be printed on one page. However, if the FCU detects that the image does not fit on one page after sub-scan reduction, the FCU cancels the page reduction, but uses normal sub-scan reduction on the received fax image.

NOTE: 1) Sub-scan reduction is automatically enabled when Page Reduction is enabled.
2) A3 to A4 reduction is not available.

Cross Reference

- Page reduction on/off - User parameter 10 (0A), bit 3 (Default: Disabled)

Examples

1. When printing a B4 size fax image on 8.5" x 11" lengthwise paper
 - Fax image size: 256 x 364 mm (10.7 x 14.3")
 - Paper size: 216 x 279 mm (8.5 x 11")
 - Reduction rate used: 82%
 - Page separation threshold: 20 mm

The received image is printed on one 8.5 x 11" sheet, because the image length after page reduction ($364 \text{ mm} \times 82\% = 298.5 \text{ mm}$) is shorter than the paper length (279 mm) plus 20 mm.

2. When printing a non-standard size (256 x 400 mm) fax image on 8.5 x 11" lengthwise paper
 - Fax image size: 256 x 400 mm (10.7 x 15.7")
 - Paper size: 216 x 279 mm (8.5 x 11")
 - Reduction rate used: 82%
 - Page separation threshold: 20 mm

The received fax image is printed on two 8.5 x 11" sheets after page separation and image rotation, because the image length after page reduction ($400 \text{ mm} \times 82\% = 328 \text{ mm}$) is longer than the paper length (279 mm) plus 20 mm.

Two In One

This function allows two small pages to be printed on one sheet of paper. However, this function only works when the machine does not have the following size of paper in the cassette.

- The same size of paper as the received image
- Paper which has the same width and sufficient length

Cross Reference

- Two in one on/off - User parameter 10 (0A), bit 1 (Default: Disabled)

2.3.2 JUST SIZE PRINTING

This function restricts the machine so that it can only print a received message on paper with the highest priority paper size.

NOTE:

- 1) Example:
 - A: The machine has A4 (lengthwise) and B4.
 - B: The A4 paper tray is empty
 - C: The machine receives an A4 (lengthwise) size message.
When just size printing is disabled, the machine prints the received image on B4 paper. When just size printing is enabled, the machine will not print on B4 paper. If the machine has A4 (sideways), the machine prints using image rotation.
- 2) When the paper tray with the highest priority paper size is empty, the machine displays 'Paper designated to print Fax/lists are empty. Refill -- size'.
- 3) When both page reduction and just size printing are enabled, page reduction is given priority

Cross Reference

- Just size printing on/off – User parameter switch 05, bit 5
Default setting is 0: Just size printing is disabled
- Just size printing while a paper cassette is pulled out – Printer switch 06, bit 0
Default setting is 0: Printing will not start

2.4 FAX COMMUNICATION FEATURES

2.4.1 SEP/SUB/PWD/SID

In 1996, ITU-T introduced the following protocol signals into the T.30 recommendations. These signals enable confidential transmission and secured polling between machines produced by different manufacturers.

SEP (Selective Polling): This signal informs the other terminal of a polling ID to enable secured (ID) polling or to select a document to poll. Up to 20 digits or characters can be sent in a SEP frame.

PWD (Password): This signal informs the other terminal of a password to enable extra security. Up to 20 digits or characters can be sent in a PWD frame.

SUB (Sub-address): This signal informs a sub-address of a destination. Some fax servers use this information to route a received fax message to a specific address in the local network.

Up to 20 digits or characters can be sent in a SUB frame.

SID (Sender ID): This signal informs the other terminal of the sender ID to identify the transmitter.

Up to 20 digits or characters can be sent in a SID frame.

The ITU-T recommendation only clarifies transmission requirements, and does not specify reception requirements. How the receiving terminal treats these signals varies with receiver terminal and manufacturer.

This machine is capable of sending SEP, SUB, PWD and SID codes in transmission or for polling reception, but it is not capable of receiving PWD and SID codes. If the machine receives one of these frames, the machine disconnects.

Selective Polling (SEP/PWD)

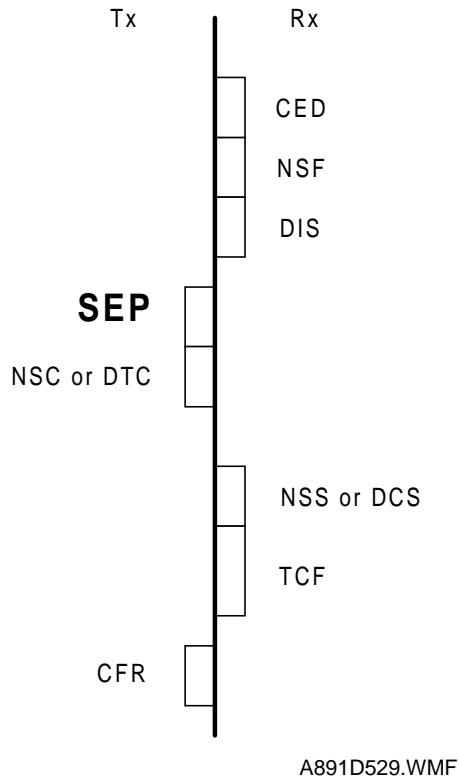

Detailed Descriptions

Sub-address (SUB)

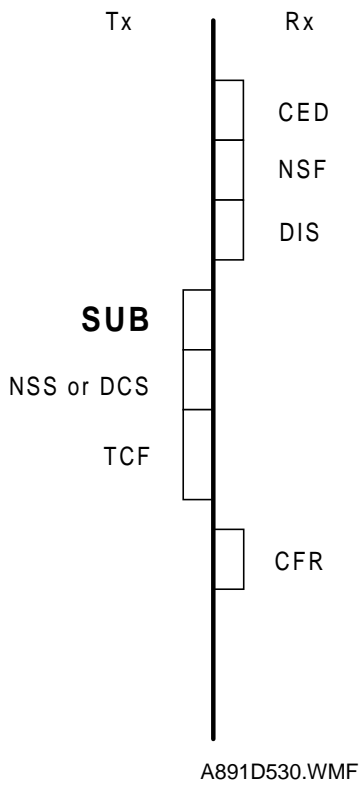

2.4.2 JBIG COMPRESSION

JBIG (Joint Bi-Level Image Coding Expert Group) is a working group which consists of members of ITU-T T.82 and ISO11544. The JBIG compression method allows data compression of approximately 1.2 to 1.3 times the MMR method in text mode, and 2 to 10 times in halftone mode.

JBIG compressed data is referred to as a Bi-level Image Entity (BIE).

The BIE consists of a header frame (BIH: Bi-level Image Header) and a compressed data frame (BID: Bi-level Image Data).

The BIH frame contains information such as main scan width (pixels), sub-scan length, and compression mode (standard/optional).

The BID frame contains the actual data.

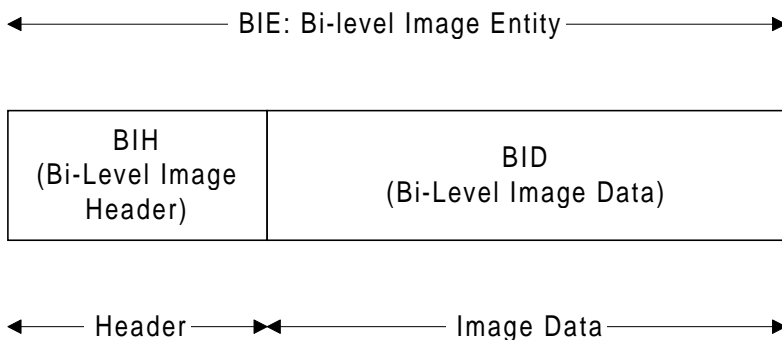

A891D531.WMF

The optional EXFUNC board is required for JBIG compression.

JBIG compression is disabled when any of the following conditions occur.

- When JBIG compression is turned off with communication switch 00.
- When ECM is turned off with communication switch 01.
- When the receiving terminal does not have the JBIG feature.
- When the receiving terminal does not have the ECM feature.

There are two modes for JBIG compression.

- Standard mode: one stripe (data block) consists of 128 lines.
- Optional mode: one stripe of one page (transmission speed with this mode is faster).

This machine supports both modes for transmission and reception. The mode used is determined during handshaking.

Cross reference: Section 4.2 Bit switches

- JBIG reception mode : Communication bit switch 00 bit 5
 0: Standard mode only 1: Standard mode and optional mode (default)
- Priority of JBIG mode used for transmission: Communication bit switch 00 bit 6
 0: Standard mode 1: Optional mode (default)

2.4.3 V.8/V.34 PROTOCOL

- NOTE:** 1) Refer to “V.8/V.34 Training Manual” for overall information about V.8/V.34 protocol.
 2) This section explains machine specific functions only.

V.8 in Manual Reception

This machine starts the V.8 procedure in order to allow V.34 communication in manual reception, though some other fax machines do not. Refer to “V.8/V.34 Training Manual – section 3.1” for detailed procedures.

Shift-down Conditions

One-step Shift-Down from the Receiving Terminal

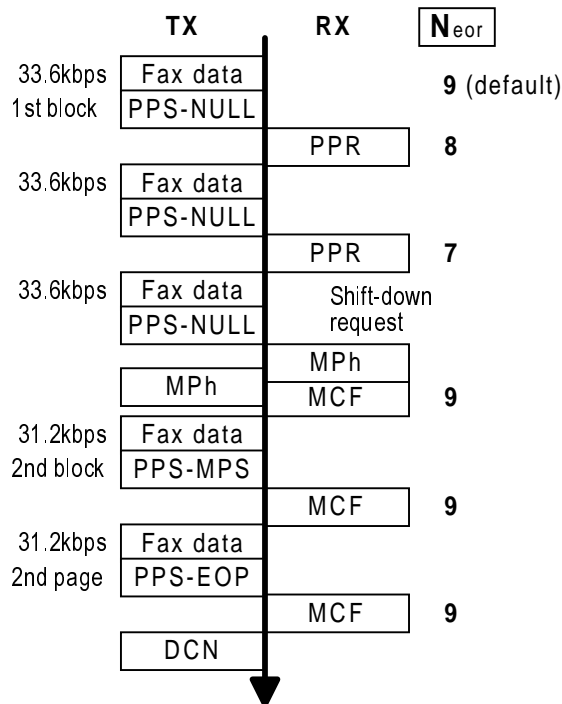

A891D532.WMF

The diagram shows the protocol used by this model acting as the receiving terminal.

If the machine has sent two PPRs for one ECM block, it will request the sending terminal to make a one-step shift-down in the next control channel.

N_{eor} : Number of frame re-transmissions remaining until the Tx terminal sends DCN to terminate the communication. This is fixed at “9”, and is not adjustable.

Two-step Shift-down from the Sending Terminal

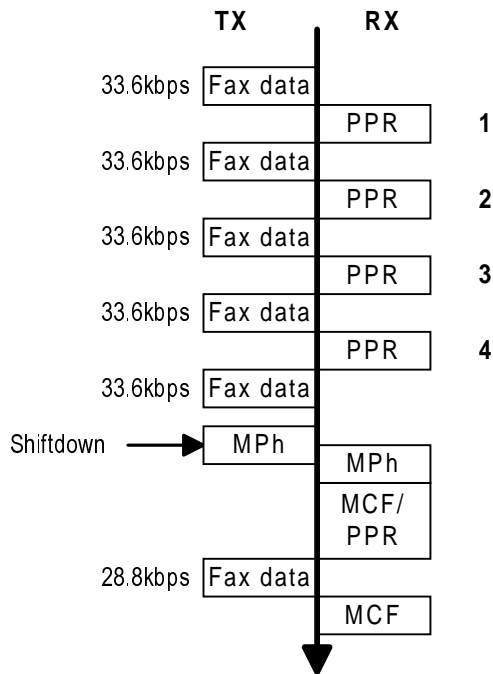

A891D533.WMF

The diagram shows the protocol used by this model acting as the sending terminal.

If this machine has received four PPRs for one ECM block, it will request the receiving terminal to accept a two-step shift-down in the next control channel.

One-step Shift-up from the Receiving Terminal

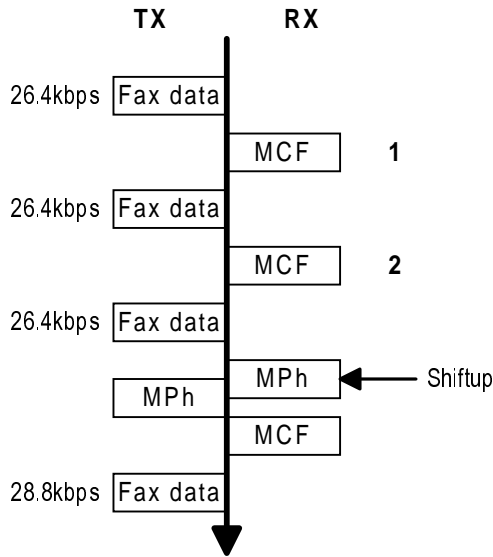

A891D534.WMF

The diagram shows the protocol used by this model acting as the receiving terminal.

If this machine has sent two consecutive MCFs and it could detect good line condition, it will request the sending terminal to make a one-step shift-up in the next control channel

Detailed Descriptions

2.5 LINE TYPE CHANGE

When the machine is initially used only with the PSTN, the line type programmed with phone numbers in Quick Dials and the Speed Dials is stored as PSTN G3. Later, if the line connection is changed so that G3 is to be used only with the ISDN, the communication port for all stored Quick and Speed Dials must be changed to ISDN G3.

This feature allows the communication mode and port to be changed for all stored numbers at once.

Procedure:

- 1) Change the data in the following RAM addresses.

68E8E4(H) - Current line type setting.

68E8E5(H) - Line type to be used after this procedure.

The default setting for the above addresses are FF(H).

- 2) Turn the main switch off and on.

Then, the machine checks all phone numbers stored in Quick Dials, Speed Dials, AI Redial, and Forwarding Stations. If the communication mode and the port setting for a number is the same as specified for the "current setting" in the above address, the machine changes these to the new setting.

- 3) After this procedure, the data programmed automatically returns to FF(H).

Setting:

Bit 0 and 1: Communication mode

| Bit | 1 | 0 | Setting |
|-----|---|---|----------|
| | 0 | 0 | G3 |
| | 0 | 1 | G4 |
| | 1 | 0 | Not used |

Bit 2 to 4: Communication port

| Bit | 4 | 3 | 2 | Setting |
|-----|---|---|---|--------------------|
| | 0 | 0 | 0 | PSTN |
| | 0 | 0 | 1 | Not used |
| | 0 | 1 | 1 | ISDN |
| | 1 | 0 | 0 | Any available port |

(This setting can be used only when an optional G3 or G4 unit is installed in the machine.)

Other settings - Not used

Bit 5 to 7: Not used

Example:

If you wish to change the port setting from PSTN G3 to ISDN G3, change the data to 00(H) (0000 0000) in the address 68E8E4(H)
change the data to 0C(H) (00001100) in the address 68E8E5(H)

Do not use this procedure if there are any files stored in the memory awaiting transmission.

2.6 PCBS

2.6.1 FCU

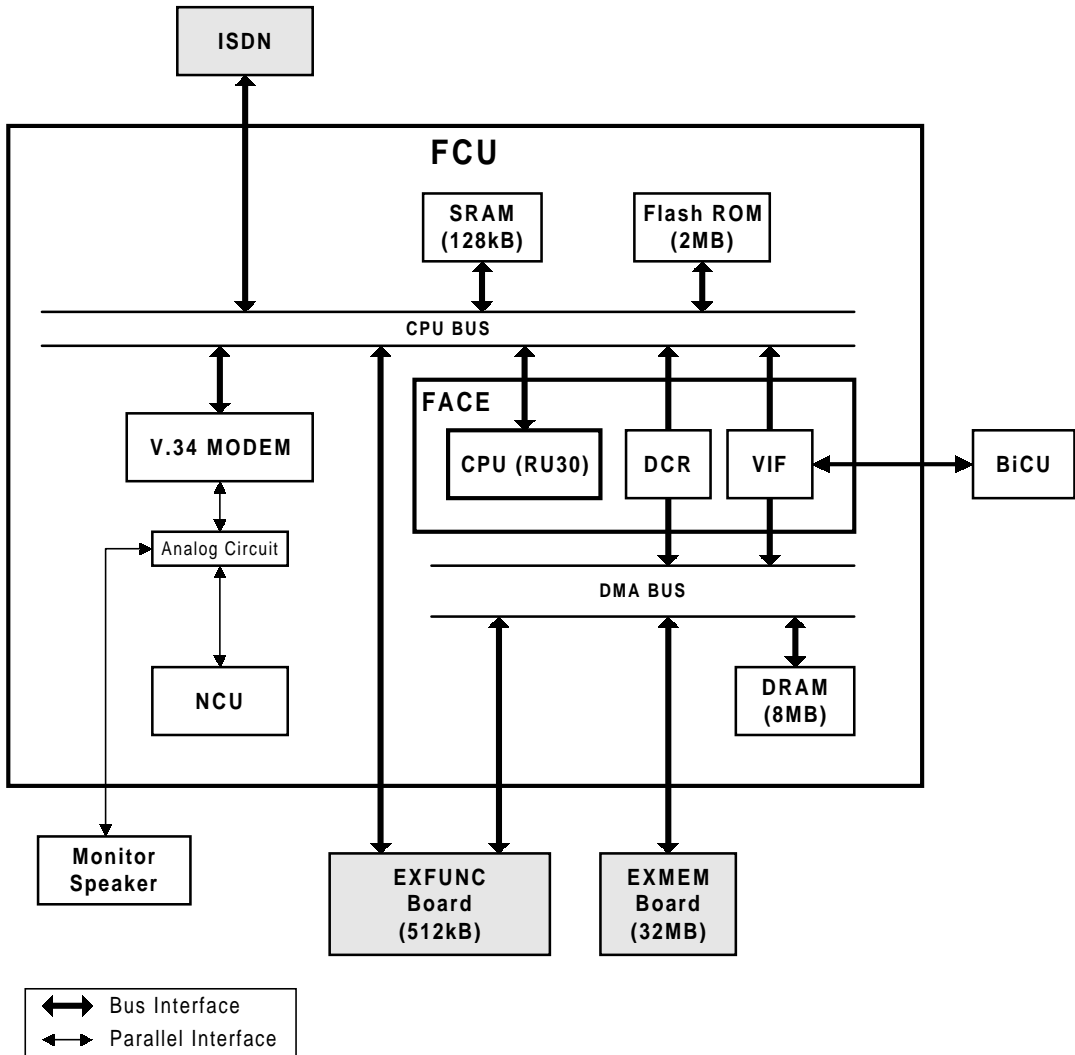

A891V500.WMF

The FCU (Facsimile Control Unit) controls fax communications, the video interface to the base copier's engine, and all the fax options.

FACE

- CPU
- Data compression and reconstruction (DCR)
- DMA control
- Clock generation
- DRAM backup control
- Ringing signal/tone detection
- Video and command interface to the BiCU (VIF)

Modem (Rockwell R288F)

- V.34, V17, V.29, V.27ter, V.21, and V.8

ROM

- 2MB (16 Mbit) flash ROM for system software storage

DRAM

- The 8 MB of DRAM is shared between SAF memory, ECM buffer, page memory, working memory, line buffer, and so on.
- The SAF memory (2MB) is backed up by a rechargeable battery.

SRAM

- The 128 KB SRAM for system and user parameter storage is backed up by a lithium battery.

Switches

| Item | Description |
|-------------|--|
| SW1 | Switches the data transfer direction between the FCU and the flash memory card |
| SW2 | Reset switch, to reboot the FCU board |
| SW3 | Switches the SRAM backup battery on/off |

2.6.2 NCU (US)

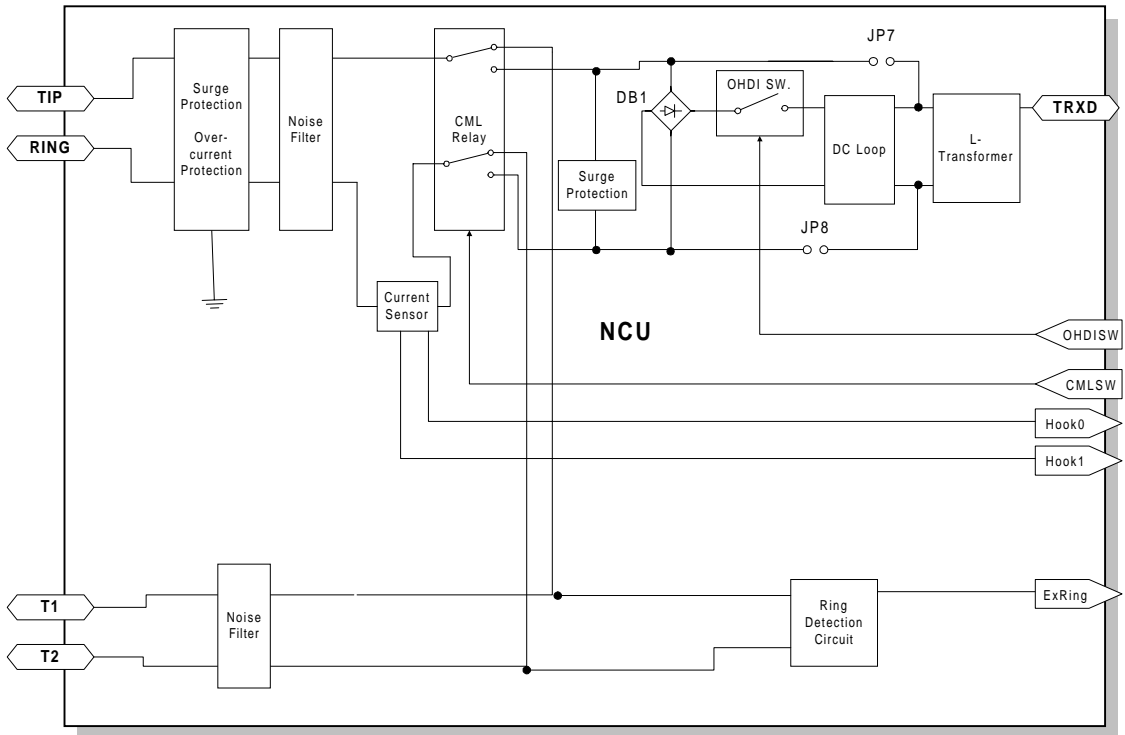

A891D520.WMF

Detailed Descriptions

Jumpers

| Item | Description |
|------|--|
| JP7 | These jumpers should be shorted when the machine is connected to a dry line. |
| JP8 | |
| DB1 | Also remove DB1 when the machine is connected to a dry line. |

2.6.4 EXFUNC BOARD

EXFUNC BOARD

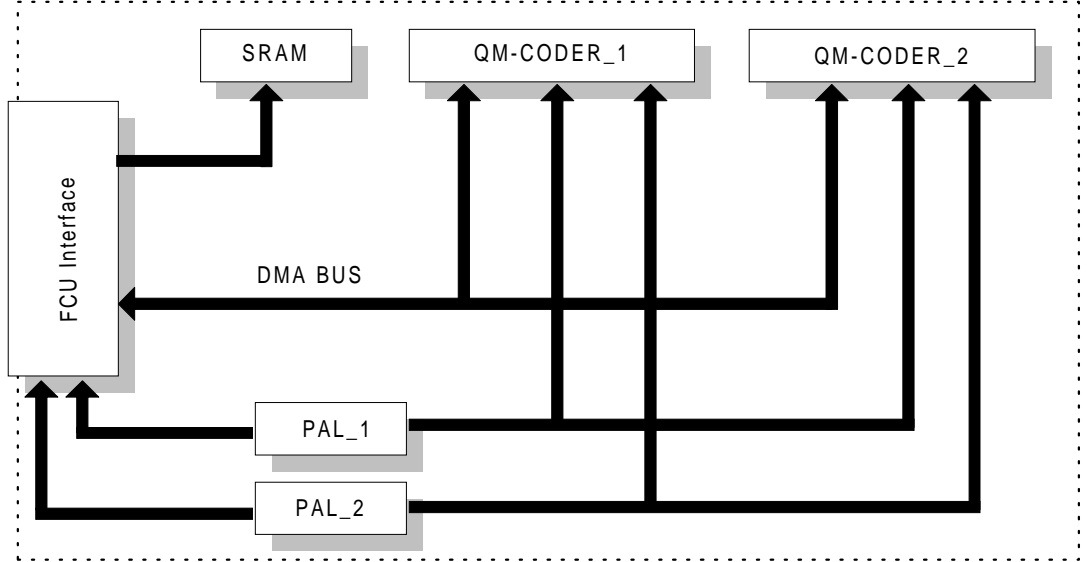

A891D522.WMF

Detailed Descriptions

The EXFUNC board allows JBIG compression and some additional features become available. In addition, this board expands the SRAM capacity.

QM Coder

- 2 QM coders for JBIG compression.

PAL (PALCE16V8H-15PC)

- 2 PALs make a strobe control signal. This is used for DMA selection.

SRAM

- 512KB SRAM for telephone numbers and other user parameters.

Lithium battery

- Backs up the SRAM.

Switches

| Item | Description |
|------|------------------------------------|
| SW1 | Switches the backup battery on/off |

3. INSTALLATION

3.1 FAX UNIT

- NOTE:**
- 1) Never install telephone wiring during a lightning storm.
 - 2) Never install telephone jacks in wet locations unless the jack is specifically designed for wet locations.
 - 3) Never touch uninsulated telephone wires or terminals unless the telephone line has been disconnected at the network interface.
 - 4) Use caution when installing or modifying telephone lines.
 - 5) Avoid using a telephone (other than a cordless type) during an electrical storm. There may be a remote risk of electric shock from lightning.
 - 6) If there is a gas leak, do not use the telephone in the vicinity of the leak to report it.

| |
|--|
|  CAUTION |
|--|

- | |
|--|
| <ol style="list-style-type: none">1. Before installing the fax unit, switch off the main power and operation switches, and disconnect the power cord.2. The fax unit contains a lithium battery. The danger of explosion exists if a battery of this type is incorrectly replaced. Replace only with the same or an equivalent type recommended by the manufacturer. Discard used batteries in accordance with the manufacturer's instructions. |
|--|

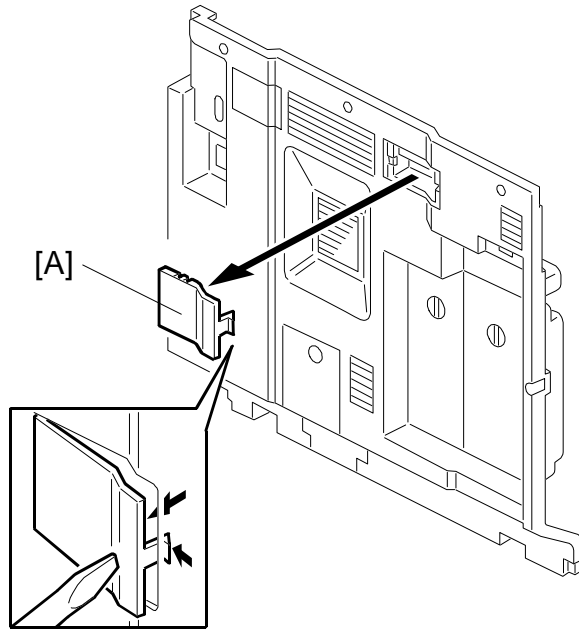

A8911516.WMF

⚠ CAUTION

Before installing this option, do the following:

- 1. If there is a printer option in the machine, print out all data in the printer buffer.**
- 2. Turn off the main switch and disconnect the power cord and the LAN cable.**

If a printer unit was installed, remove it before installing the fax unit.

1. Remove the current NCU cover [A] from the copier rear cover.

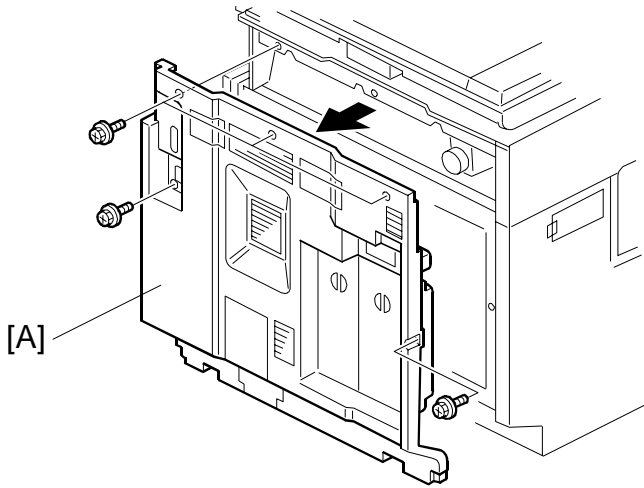

A8911575.WMF

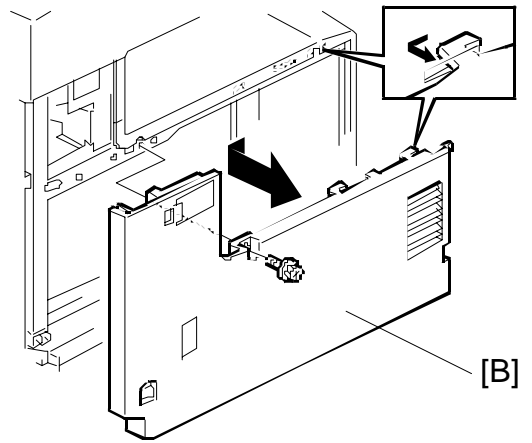

A8911576.WMF

2. Remove the rear cover [A] (5 screws).
3. Remove the left cover [B], as shown (1 screw).

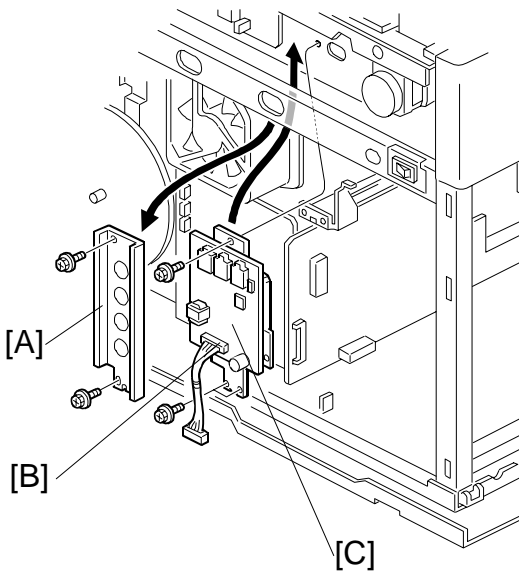

A8911593.WMF

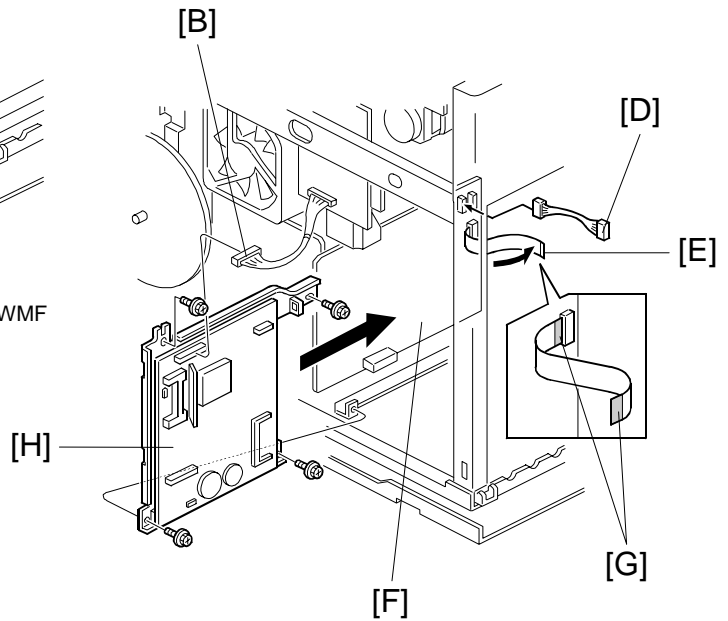

A8911521.WMF

4. Remove the bracket [A].
5. Connect the NCU connector [B] (CN3) to the NCU board [C], and install the NCU board (3 screws).
6. Connect the power supply cable [D] (CN114) and flat cable [E] (CN113) to the BiCU board [F].

Note: When connecting the flat cable, make sure that the blue edges [G] of flat cable face the left side of the machine (i.e., away from the BiCU board).
7. Install the FCU board assembly [H] (4 screws).

Note: When installing the FCU board assembly, make sure not to pinch the harnesses and flat cable.

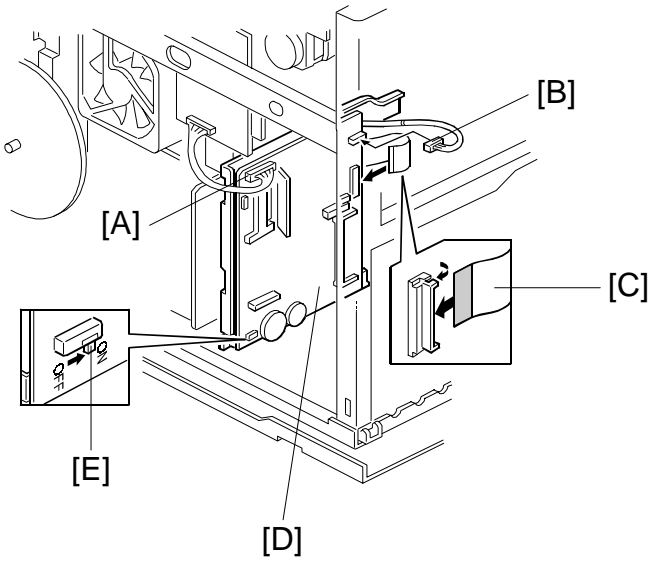

A891I522.WMF

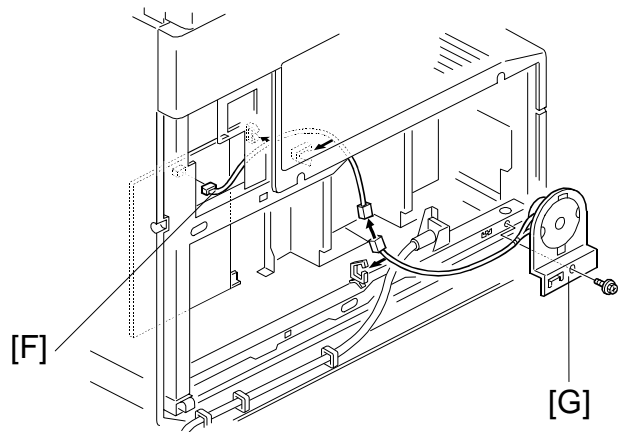

A891I520.WMF

8. Connect the NCU connector [A] (CN605), FCU connector [B] (CN651), and flat cable [C] (CN650) to the FCU board [D].
9. Turn on the FCU battery switch (SW3) [E].
10. Install the cable [F] (CN607) and the speaker assembly [G] (1 screw and 1 connector), and secure the cables to the clamps, as shown.
11. Re-install the rear and left covers.

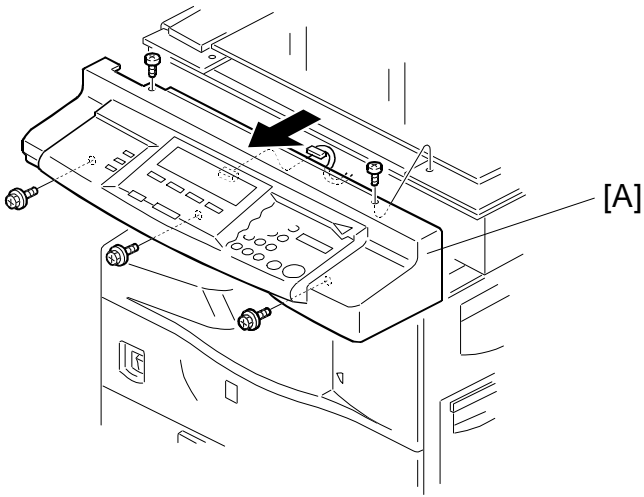

A8911523.WMF

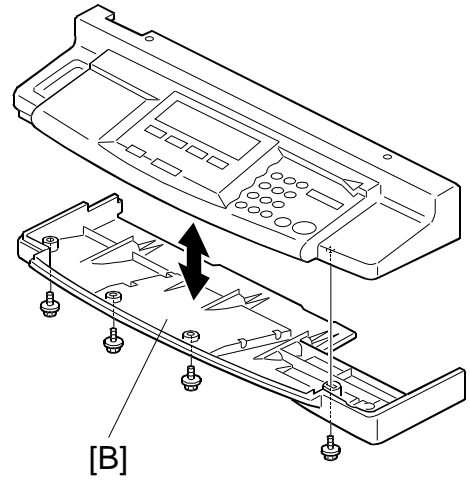

A8911553.WMF

12. Remove the operation panel [A] (5 screws and 1 connector).
13. Remove the lower operation panel cover [B] (4 screws).

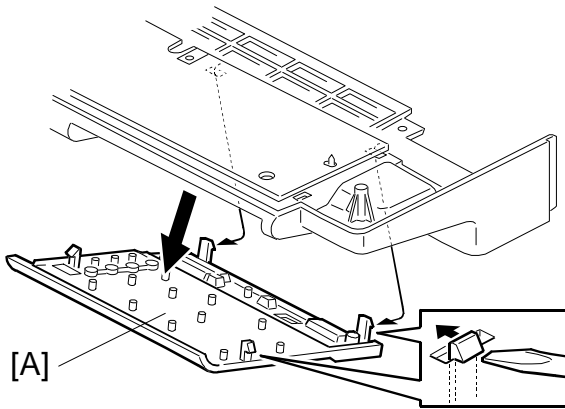

A8911524.WMF

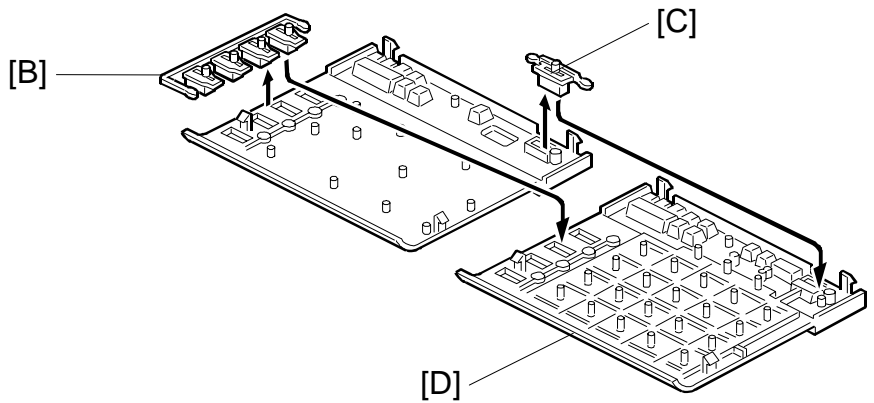

A8911525.WMF

14. Remove the left panel [A] (4 hooks).
15. Remove the parts [B] and [C] from the left panel and install them on the left panel [D] for the fax.
16. Install the left panel.

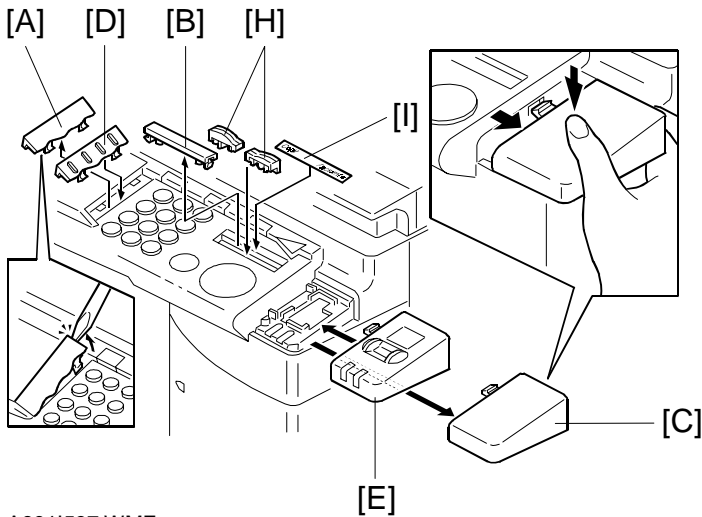

A8911537.WMF

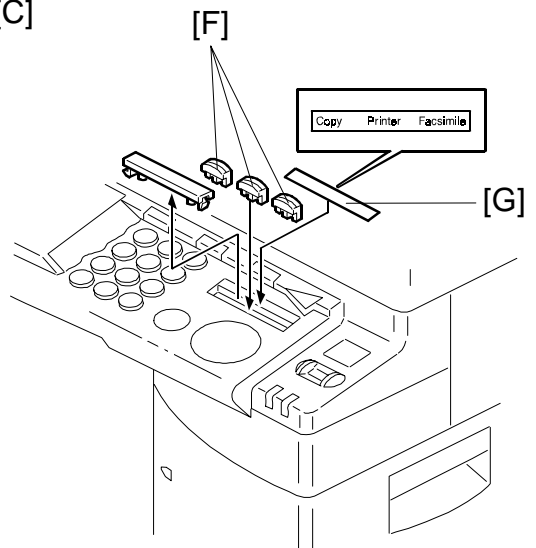

A8911539.WMF

17. Re-install the lower operation panel cover.
18. Re-install the operation panel.
19. Remove parts [A], [B] and [C] from the operation panel.
20. Install parts [D] and [E] on the operation panel.
21. **If the machine has the printer controller option:** Install the keys [F] and the decal [G] (instead of the basic decal) as shown. The decal [G] has "Copy," "Printer," and "Facsimile" on it.
If the machine does not have the printer controller option: Install the keys [H] and the decal [I] as shown. The decal [I] has "Copy" and "Facsimile" on it.

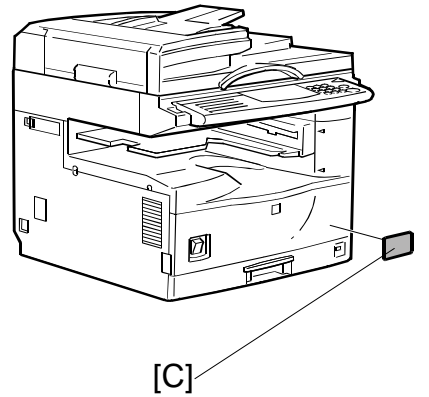
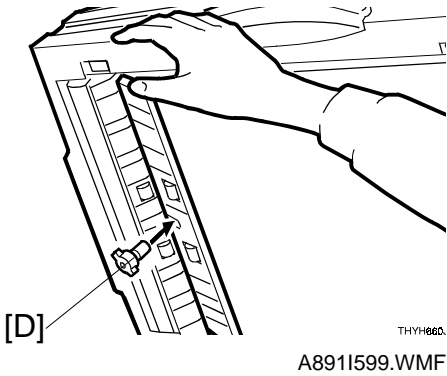
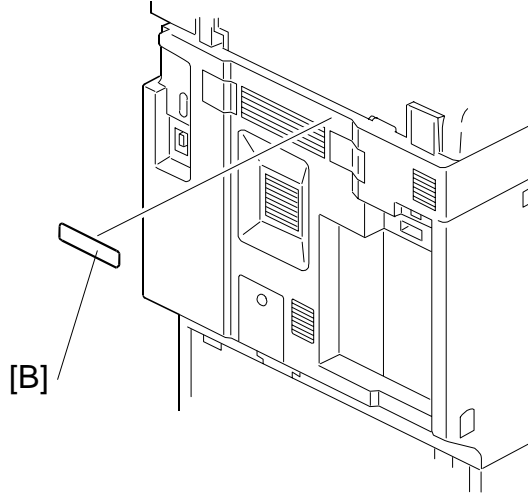
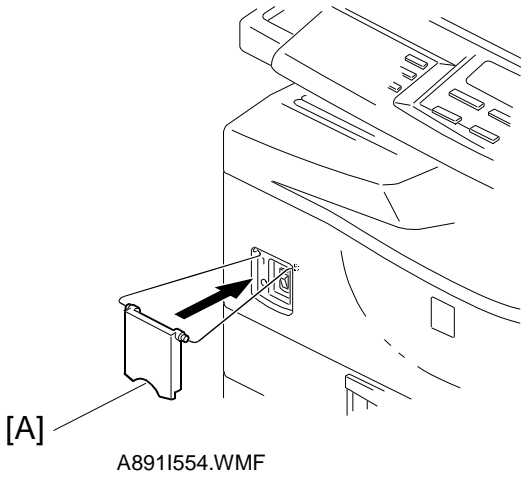

22. Install the main switch cover [A].
23. Attach the FCC decal [B] to the rear cover, and the Super G3 decal [C] to the front cover.
24. Install the stamp [D] as shown.
25. Turn on the machine. The machine displays "SC1201".
NOTE: The machine always displays "SC1201" the first time the fax unit is powered up. Please ignore it.



3.2 EXFUNC BOARD (FAX FUNCTION UPGRADE)

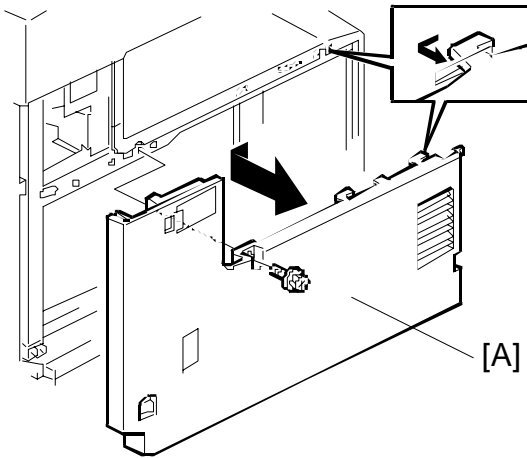

A8911576.WMF

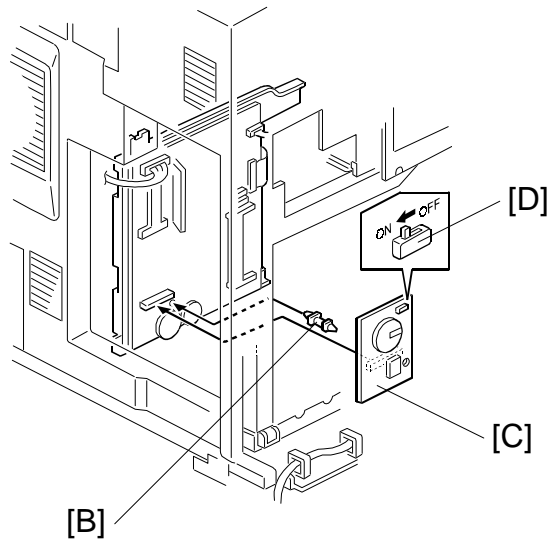

A8911519.WMF

⚠ CAUTION

Before installing this option, do the following:

1. **Print out all messages stored in the memory, the lists of user-programmed items, and the system parameter list.**
2. **If there is a printer option in the machine, print out all data in the printer buffer.**
3. **Turn off the main switch and disconnect the power cord, the telephone line, and the LAN cable.**

- NOTE:** 1) If a printer unit was installed, remove it before installing the EXFUNC board.
- 2) After installing or removing the EXFUNC board, the following message will appear: 'Adding FAX Feature Expander causes data loss. Turn Main Power Switch off and remove it to avoid loss. To continue, press yes.' If the customer does not wish to lose the data stored in the machine so far (such as Speed Dials), do the following:
- a) Do not press Yes. Switch off and take out the EXFUNC card.
 - b) Copy the SRAM settings to a flash card (see Removal and Adjustment – SRAM Data Backup and Restore).
 - c) Put the EXFUNC card back in and switch on the machine.
 - d) When the message appears again, press Yes.
 - e) Restore the SRAM settings from the flash card.

1. Remove the left cover [A], as shown (1 screw).
2. Install the locking support [B].
3. Install the EXFUNC board [C].
4. Turn on the battery switch (SW1) [D].
5. Re-install the left cover.
6. Turn on the machine. The machine displays "SC1207".
NOTE: The machine always displays "SC1207" the first time the EXFUNC board is powered up. Please ignore it.

3.3 PCFE UNIT (PC-FAX EXPANDER UPGRADE)

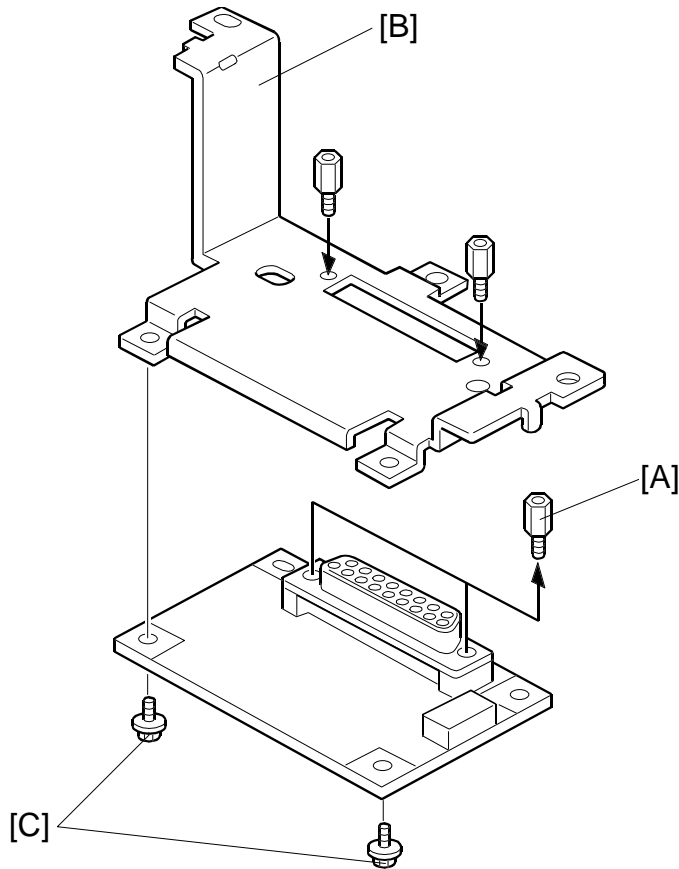

A891I583.WMF

⚠ CAUTION

Before installing this option, do the following:

- 1. Print out all messages stored in the memory, the lists of user-programmed items, and the system parameter list.**
- 2. If there is a printer option in the machine, print out all data in the printer buffer.**
- 3. Turn off the main switch and disconnect the power cord, the telephone line, and the LAN cable.**

If a printer unit was installed, remove it before installing the PC fax expander.

1. Remove the two screws [A].
2. Install the bracket [B] (4 screws [A] and [C]).

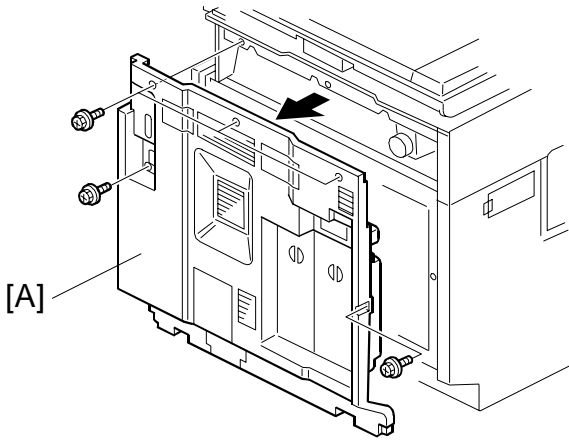

A891I575.WMF

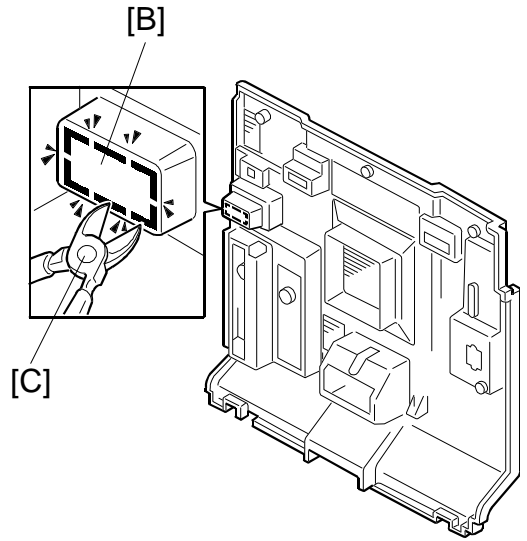

A891I582.WMF

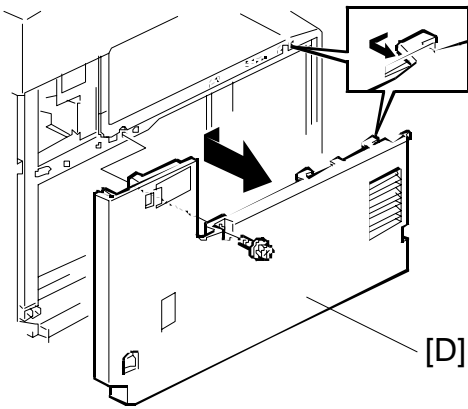

A891I576.WMF

3. Remove the rear cover [A] (5 screws).
4. Remove the cover [B] from the copier rear cover with wire cutters [C].
5. Remove the left cover [D], as shown (1 screw).

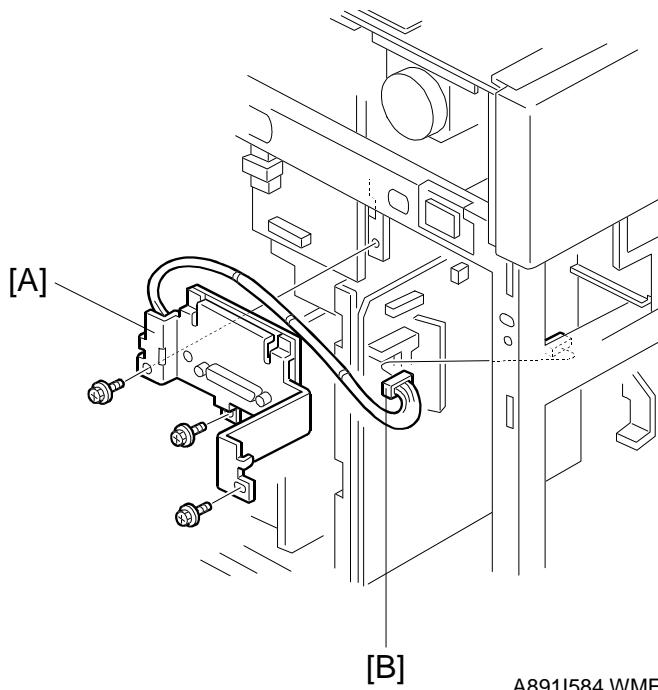

A8911584.WMF

6. Install the PC fax expander [A] (2 screws).
Note: If the printer unit will be installed, install it before installing the PC fax expander.
7. Connect the connector [B] to the FCU board.
8. Re-install the rear and left covers.
9. Plug in the machine and turn on the main switch.
10. Enter SP mode as follows:
 - 1) Press the "Clear Modes" key.
 - 2) Enter "107"
 - 3) Press the "Clear/Stop" key more than 3 seconds.



11. Enter "2" (select "Fax").
12. Enter "01" (select "Bit Switches").
13. Enter "1" (select "System Switch").
14. Press the "↑ Switch" key several times and select "Switch 1C".
15. Enter "0" and change bit 0 from 0 to 1.
16. Exit SP mode and turn the main switch off/on.

3.4 HANDSET (USA MODELS ONLY)

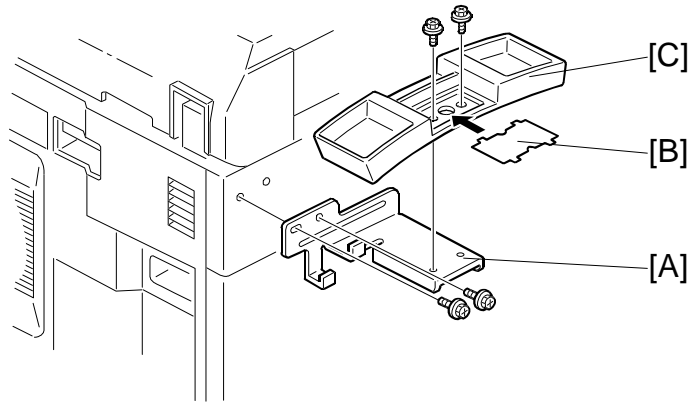

A891I1540.WMF

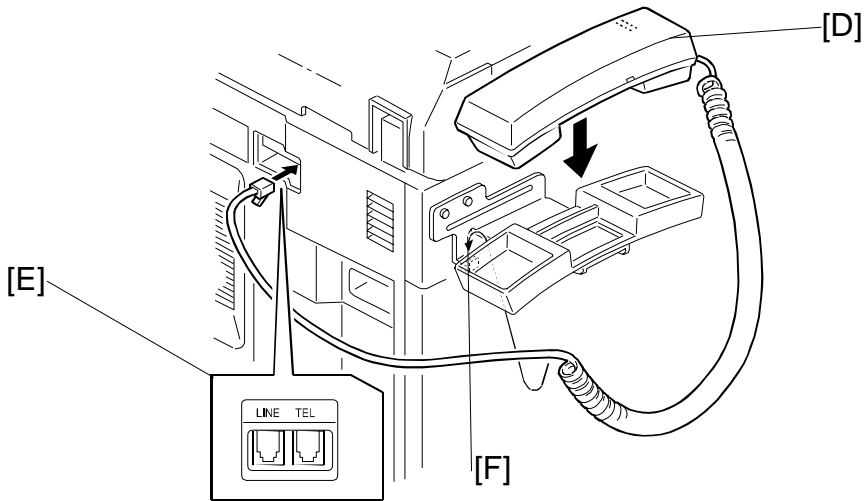

A891I1541.WMF

1. Attach the bracket [A] (3 screws) to the left cover.
2. Remove the label [B] from the handset cradle [C]. Attach the cradle to the bracket [A] (2 screws), then replace the label [B].
3. Install the handset [D], then connect the cable to the "TEL1" or "TEL2" jack [E] at the rear of the machine, as shown.
4. Hook the curled cord onto the bracket as shown [F].

3.5 EXMEM BOARD (EXPANSION MEMORY)

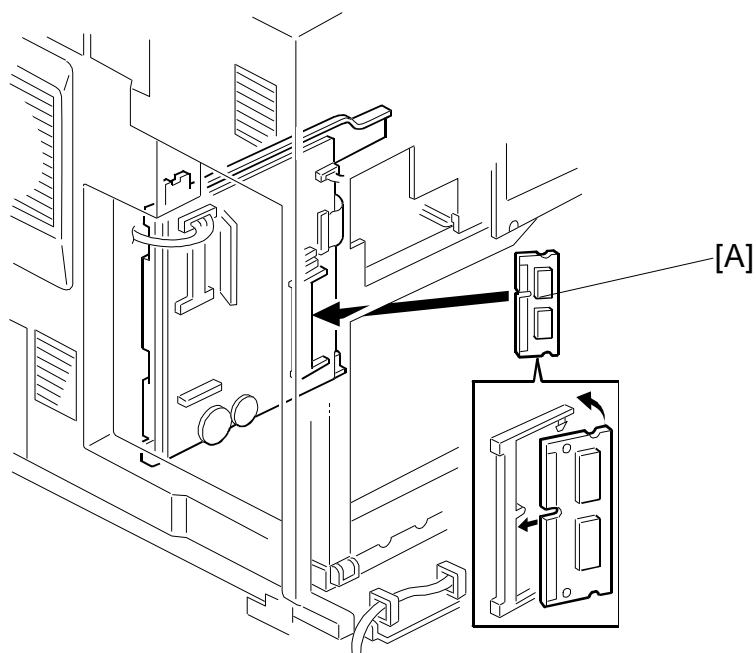

A891I518.WMF

1. Remove the left cover.
2. Install the EXMEM board [A].
Tilt the EXMEM board so that it is 45 degrees from the FCU, and slide it into the slot as shown.
It should make an audible click as it pops into place.
3. Re-install the left cover.

4. SERVICE TABLES

4.1 SERVICE LEVEL FUNCTIONS

4.1.1 HOW TO ENTER AND EXIT THE FAX SERVICE MODE

To Enter Fax Service Mode:

1. Ensure that the machine is in standby mode.
2. Press (1) (0) (7), then hold down for more than 3 seconds.
The SP mode main menu appears.
3. Press to enter the fax service mode.

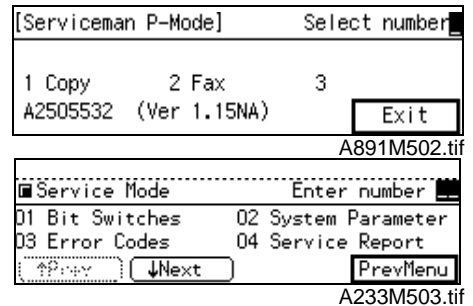

To Exit Fax Service Mode:

1. Press or 'PrevMenu' until the SP mode main menu appears.
2. Press the key.

4.1.2 BIT SWITCH PROGRAMMING (FUNCTION 01)

1. Enter the fax service mode.
2. Press .
3. Press one of the following numbers, as required:
 - System bit switches
 - Scanner bit switches
 - Printer bit switches
 - Communication bit switches
 - G3 bit switches
 - G4 internal switches (Europe model only)
 - G4 parameter switches (Europe model only)

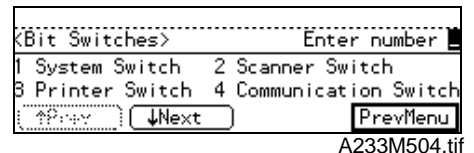

NOTE: An optional G4 interface is required to access the G4 internal and G4 parameter bit switches.

Example:

1. Press
2. Scroll through the bit switches.
 To increment the bit switch number:
 press '↓ Switch'.
 To decrement the bit switch number:
 press '↑ Switch'.

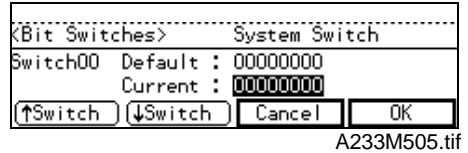

Example:

To display bit switch 03: Press '↓ Switch' 3 times.

3. Adjust the bit switch.
 Example:
 To change the value of bit 7, press 7.
4. To adjust more bit switches, go to step 2.
 To finish, press 'OK' then 'PrevMenu'.
5. Exit the service mode.

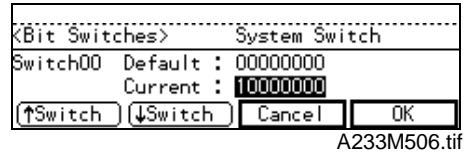

NOTE: After changing any of the G4 bit switches, be sure to turn the main power switch off and back on to activate the new settings.

4.1.3 SYSTEM PARAMETER LISTS (FUNCTION 02)

1. Enter the fax service mode.
2. Press
3. Press
4. Press
5. Exit the service mode.

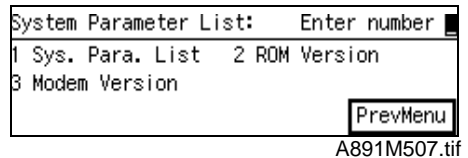

NOTE: Pages 5 and 6 of the system parameter list are for designer use only. However some information may be useful for service technicians. See the next page.

- An example of the system parameter list (pages 5 and 6) –

```

* * * SYSTEM PARAMETER LIST (Date and Time) * * *
                                                    1)TTI 1
                                                    2)TTI 2

And later is information for a design.

REST ENTRY DATA
  TMP DIAL:1005  One key:30  Speed key:1000  PRG JOB:32  PRG DIAL:2000
  Rest Job file:1003(max:1004)  Rest Dial file:2002(max:2002)
Resoucee
  Free:0x0FFEFDFD  Bad:0x0000001D  CCU:0x00  [P1|XX|XX|XX|S|p|H]
SAF CAPACITY
  100%(Rest block:0x1E00)
Receive
  Now status          0x00 OK

CCU TX ERROR

```

```

* * * SYSTEM PARAMETER LIST (Date and Time) * * *
                                                    1)TTI 1
                                                    2)TTI 2

Task Status
ID  TASK  PRI  STS  ISP  START  SP  PC
00  idle  20  RDY  0x00800A5E  0x00004530  0x00800A5E  0x00004530
01  :      :      :      :      :      :      :

```

A891M600.WMF

REST ENTRY DATA

TEMP DIAL: Remaining number of destinations that can be programmed at the ten-key pad.

One key: Remaining number of destinations that can be programmed as Quick Dials

Speed key: Remaining number of destinations that can be programmed as Speed Dials

PRG JOB: Remaining number of keystroke programs that can be programmed

PRG DIAL: Remaining number of destinations that can be used in keystroke programs.

Rest Job file: Number of remaining job files that can be used.

Rest Dial file: Number of remaining destinations that can be used.

4.1.4 FCU ROM VERSION DISPLAY (FUNCTION 02)

1. Enter the fax service mode.
2. Press then

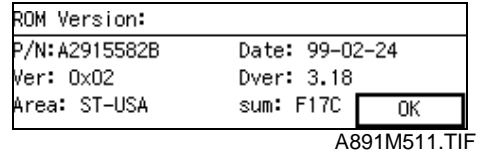

3. Exit the service mode.

Note: The check-sum value displayed is calculated in 16-bit little endian format.

4.1.5 MODEM PROGRAM VERSION DISPLAY (FUNCTION 02)

1. Enter the fax service mode.
2. Press then

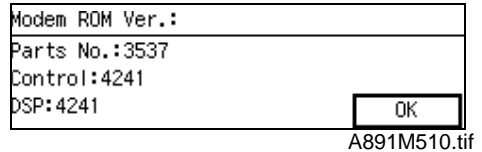

3. Exit the service mode.

4.1.6 ERROR CODE DISPLAY (FUNCTION 03)

1. Enter the fax service mode.
2. Press
3. Press either Prev. or Next to scroll through the error codes.
4. Exit the service mode.

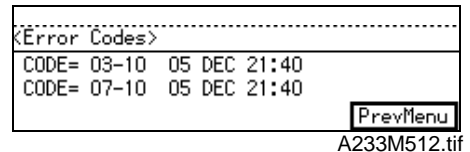

4.1.7 SERVICE MONITOR REPORT (FUNCTION 04)

1. Enter the fax service mode.
2. Press then
3. Exit the service mode.

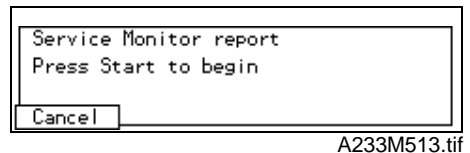

4.1.8 G3 PROTOCOL DUMP LIST (FUNCTION 05)

1. Enter the fax service mode.
2. Press
3. Press then
4. Exit the service mode.

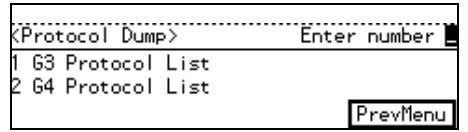

4.1.9 G4 PROTOCOL DUMP LIST (FUNCTION 05)

NOTE: An optional G4 interface is required to print the G4 protocol dump list.

1. Enter the fax service mode.
2. Press
3. Press
4. Press one of the following numbers as required:
 - D + Bch
 - Dch
 - Bch1 Link
 - Dch Link
5. Exit the service mode.

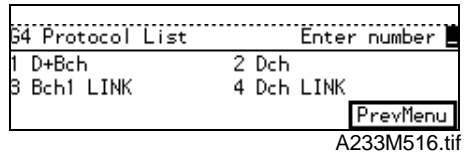
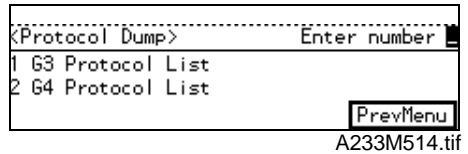

4.1.10 RAM DISPLAY AND REWRITE (FUNCTION 06)

1. Enter the fax service mode.
2. Press
3. Press

4. Enter the start address of the RAM area to be displayed, then press OK.

5. Move the cursor to the target address using the arrow keys, then enter a new value (0-9: ten-key pad, A-F: Quick Dial keys).
6. To scroll through the RAM addresses: press Prev. or Next.
To jump to an another address: press OK, and go back to step 3.
7. Exit the service mode.

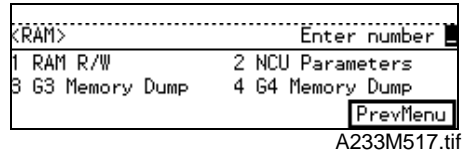

A233M517.tif

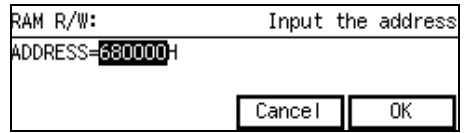

A891M514.tif

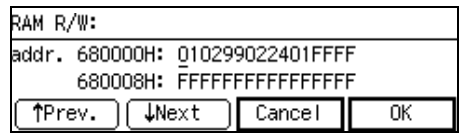

A891M515.tif

4.1.11 NCU PARAMETERS (FUNCTION 06)

1. Enter the fax service mode.
2. Press
3. Press

4. Move the cursor to the target parameter using the arrow keys, then enter a new value at the ten-key pad.
5. Exit the service mode.

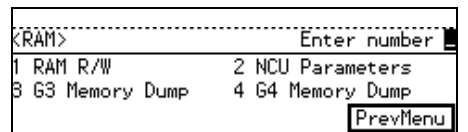

A233M517.tif

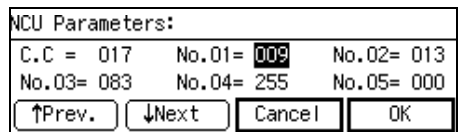

A891M516.tif

4.1.12 RAM DUMP (FUNCTION 06)

1. Enter the fax service mode.
2. Press
3. Press one of the following numbers as required:
 - G3 memory dump list
 - G4 memory dump list (Europe model only)

NOTE: An optional G4 interface is required to print the G4 memory dump list.
4. Enter the first four digits of the start and end addresses, then press 'OK'
 Example: Start at 480000, end at 4801FF
 'OK'
5. Press
6. Exit the service mode.

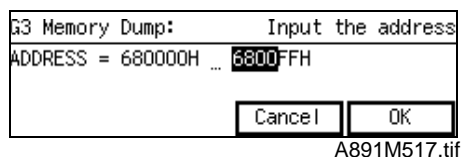
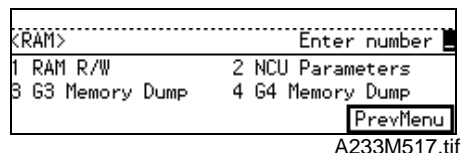

4.1.13 RAM CLEAR (FUNCTION 07)

1. Enter the fax service mode.
2. Press
3. Press one of the following numbers, as required:
 - Initializes the data in the SRAM, files in the SAF memory, and the clock.
 - Erases all the files stored in the SAF memory.
 - Resets the bit switches and the user parameters.
 - Initializes the data in the SRAM and files in the SAF memory.
4. The machine automatically returns to standby mode after self-initialization.

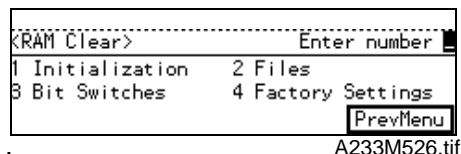

4.1.14 FCU REBOOT

To initialize the fax unit without erasing files or resetting the bit switches, do one of the following:

- Hold down the "Speed Dial" key for more than 10 s, while the machine is in facsimile mode. This initializes the fax unit only.
- Remove the rear cover and press SW2 on the FCU. This initializes the fax unit only.
- Turn off the main power and operation switches and turn them back on. This initializes the whole machine.
- Hold down the and keys for more than 10 s. This initializes the whole machine.

4.1.15 SERVICE STATION FAX NUMBER (FUNCTION 09)

1. Enter the fax service mode.
2. Press
3. Enter the fax number of the service station that will receive Automatic Service Calls from this machine. To use a G4 number, press the 'F4' key.
4. Press OK.
5. Exit the service mode.

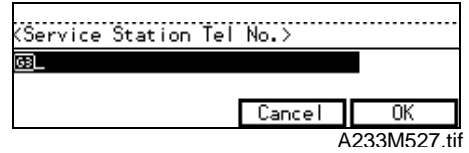

4.1.16 SERIAL NUMBER (FUNCTION 10)

1. Enter the fax service mode.
2. Press
3. Enter the fax unit's serial number at the keypad, then press OK.
4. Exit the service mode.

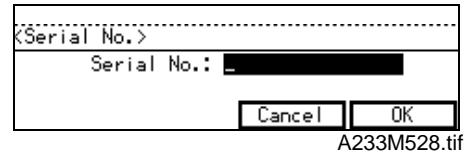

4.1.17 MODEM TEST (FUNCTION 11)

1. Enter the fax service mode.
2. Press
3. Press one of the following numbers:
 - Modem test (analog line)
 - Modem test (ISDN line: Europe model only)

NOTE: An optional ISDN interface is required to test a modem on an ISDN line.
4. Press
5. Choose a modem signal type at the keypad, then press . To stop, press .
6. Exit the service mode.

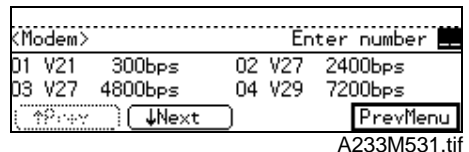
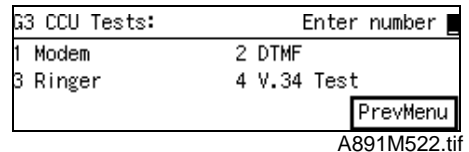
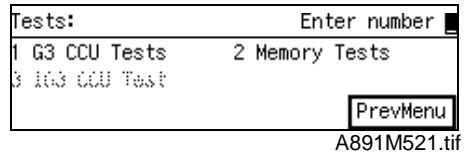

4.1.18 V.34 MODEM TEST (FUNCTION 11)

1. Enter the service mode.
2. Press **1** **1** then **1**
3. Press **4**
4. Select a symbol rate and a data rate, then press OK.
 - 1** – Select a symbol rate
 - 2** – Select a data rate
5. Press “Start” to start the test.
To stop the test, press “Stop”.
6. Exit the service mode.

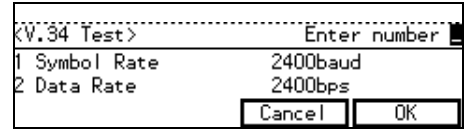

A233M540.tif

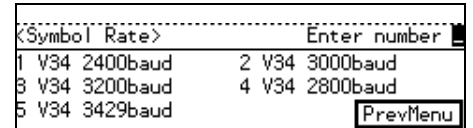

A233M542.tif

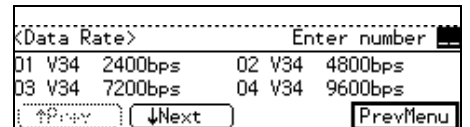

A233M541.tif

4.1.19 DTMF TEST (FUNCTION 11)

1. Enter the fax service mode.
2. Press **1** **1**
3. Press one of the following numbers:
 - 1** – DTMF test (analog line)
 - 3** – DTMF test (ISDN line: Europe model only)

NOTE: A G4 interface is required to test DTMF tones on an ISDN line.
4. Press **2**
5. Choose a DTMF signal type at the keypad, then press **↕**
To stop the test, press **C/⊗**

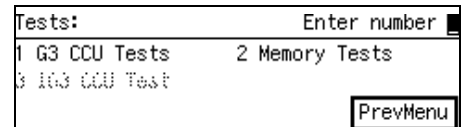

A233M529.tif

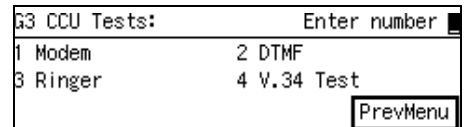

A233M530.tif

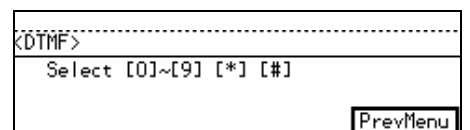

A233M535.tif

4.1.20 RINGER TEST (FUNCTION 11)

1. Enter the fax service mode.
2. Press **1** **1**

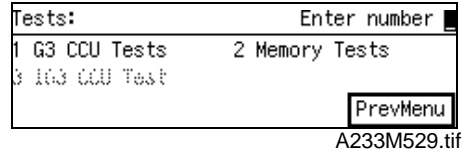

3. Press **1**

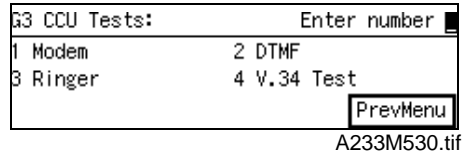

4. Press **3** then **◊**
To stop the test, press **C/⊗**

5. Exit the service mode.

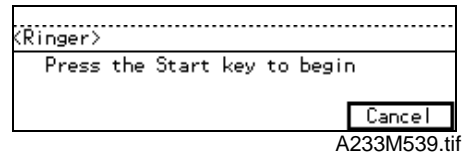

4.1.21 MEMORY TEST (FUNCTION 11)

1. Enter the fax service mode.
2. Press **1** **1**
3. Press **2**
4. Press one of the following numbers:

| | | |
|----------|---|-----------|
| 1 | - | SRAM test |
| 2 | - | DRAM test |
5. Press "Start" to start the test.
To stop the test, press "Stop".
If the test is successful, the display shows "OK".
If the test is unsuccessful, the display shows "NG".
6. Exit the service mode.

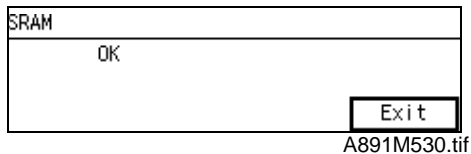
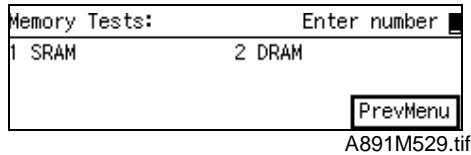

4.1.22 FILE PRINTOUT (FUNCTION 13)

1. Enter the fax service mode.
2. Press then
The machine prints all the files stored in the SAF memory, including confidential messages.

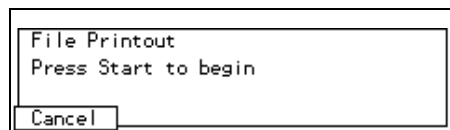

A233M561.tif

NOTE: Do not use this function, unless the customer is having trouble printing confidential messages or recovering from a memory lock status.

4.1.23 JOURNAL PRINTOUT (FUNCTION 14)

1. Enter the fax service mode.
2. Press
3. Either:
 - Choose All** - The machine prints all the communication records on the report. The maximum is 100 records, or 900 records if the optional EXFUNC board is installed.
 - Specify a date** - The machine prints all communication records after the specified date.
4. Exit the service mode.

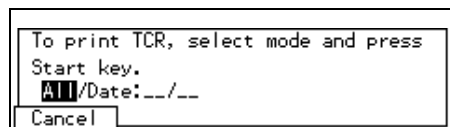

A233M562.tif

4.1.24 USAGE LOG PRINTOUT (FUNCTION 15)

The following functions are for designer use only. However, list 5 (SC history) may be useful.

1. Enter the fax service mode.
2. Press
3. Press the number, then press
 – SC history
4. Exit the service mode.

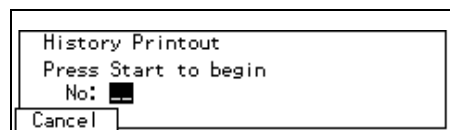

A233M563.tif

4.1.25 DATA TRANSFER (FUNCTION 16)

This function allows ROM and SRAM data transfer between the FCU inside the machine and an external flash memory card or FCU. Refer to the following sections for details.

- Section 6.4.1 - FCU ROM download from a flash memory card
- Section 6.4.2 - FCU ROM upload to a flash memory card
- Section 6.5.1 - SRAM backup to a flash memory card
- Section 6.3.3 - SRAM restore from a flash memory card
- Section 6.3.2 – SRAM restore from FCU

4.2 BIT SWITCHES

WARNING

Do not adjust a bit switch or use a setting that is described as “Not used”, as this may cause the machine to malfunction or to operate in a manner that is not accepted by local regulations. Such bits are for use only in other areas, such as Japan.

NOTE: Default settings for bit switches are not listed in this manual. Refer to the System Parameter List printed by the machine.

4.2.1 SYSTEM SWITCHES

| System Switch 00 | | |
|------------------|--|---|
| No | FUNCTION | COMMENTS |
| 0-1 | Not used | Do not change the settings. |
| 2 | Technical data printout on the Journal 0: Disabled 1: Enabled | 1: Instead of the personal name, the following data are listed on the Journal for each G3 communication. |
| | e.g. 0000 32V34 288/264 L01000304 (1) (2)(3) (4) (5) (6) (7)(8) | |
| | (1): EQM value (Line quality data). The left hand figure is the high byte and the right hand figure is the low byte. A larger number means more errors. (2): Symbol rate (V.34 only) (3): Final modem type used (4): Starting data rate (for example, 288 means 28.8 kbps) (5): Final data rate (6): Rx level (refer to the note after this table for how to read the rx level) (7): Total number of error lines that occurred during non-ECM reception. (8): Total number of burst error lines that occurred during non-ECM reception. Note: EQM and rx level are fixed at "FFFF" in tx mode. The seventh and eighth numbers are fixed at "00" for transmission records and ECM reception records. | |
| | Rx level calculation Example: 0000 32 V34 288/264 L <u>01 00</u> 03 04 The four-digit hexadecimal value (N) after "L" indicates the rx level. The <u>high</u> byte is given first, followed by the <u>low</u> byte. Divide the decimal value of N by -16 to get the rx level. In the above example, the decimal value of N (= 0100 [H]) is 256. So, the actual rx level is 256/-16 = -16 dB | |
| 3-4 | Not used | Do not change the settings. |
| 5 | G3/G4 communication parameter display 0: Disabled 1: Enabled | This is a fault-finding aid. The LCD shows the key parameters (see below). This is normally disabled because it cancels the CSI display for the user. Be sure to reset this bit to 0 after testing. |

| System Switch 00 | | |
|-------------------------|---|--|
| No | FUNCTION | COMMENTS |
| 6 | Protocol dump list output after each communication 0: Off 1: On | This is only used for communication troubleshooting. It shows the content of the transmitted facsimile protocol signals. Always reset this bit to 0 after finishing testing. The setting of system switch 09 bit 6 determines the types of communication that the list is printed after. |
| 7 | Amount of protocol dump data in one protocol dump list printout operation 0: Up to the limit of the memory area for protocol dumping 1: Last communication only | Change this bit to 1 if you want to have a protocol dump list of the last communication only. If bit 6 is turned on, the machine prints a protocol dump list for the last communication only, regardless of this bit setting. If system switch 09 bit 6 is at '1', the list is only printed if there was an error during the communication |

G3 Communication Parameters

| | |
|---------------------|--|
| Modem rate | 336: 33600 bps 168: 16800 bps 312: 31200 bps 144: 14400 bps 288: 28800 bps 120: 12000 bps 264: 26400 bps 96: 9600 bps 240: 24000 bps 72: 7200 bps 216: 21600 bps 48: 4800 bps 192: 19200 bps 24: 2400 bps |
| Resolution | S: Standard (8 x 3.85 dots/mm) D: Detail (8 x 7.7 dots/mm) F: Fine (8 x 15.4 dots/mm) SF: Superfine (16 x 15.4 dots/mm) 21: Standard (200 x 100 dpi) 22: Detail (200 x 200 dpi) 44: Superfine (400 x 400 dpi) |
| Compression mode | MMR: MMR compression MR: MR compression MH: MH compression JBO: JBIG compression (Optional mode) JBB: JBIG compression (Basic mode) |
| Communication mode | ECM: With ECM NML: With no ECM |
| Width and reduction | A4: A4 (8.3"), no reduction B4: B4 (10.1"), no reduction A3: A3 (11.7"), no reduction |
| I/O rate | 0: 0 ms/line 10: 10 ms/line 25: 2.5 ms/line 20: 20 ms/line 5: 5 ms/line 40: 40 ms/line Note: "40" is displayed while receiving a fax message using AI short protocol. |

G4 Communication Parameters

| | |
|---------------------|---|
| Compression mode | MMR: MMR compression MR: MR compression MH: MH compression |
| Resolution | 21: Standard (200 x 100 dpi) 22: Detail (200 x 200 dpi) 44: Superfine (400 x 400 dpi) |
| Width and reduction | A4: A4 (8.3"), no reduction B4: B4 (10.1"), no reduction A3: A3 (11.7"), no reduction |
| Transfer | T: Transfer - : Other |
| Confidential | C: Confidential - : Other |
| Other parameters | The following information is shown in 6-bit format. Bit 1 is the first bit from the left, and bit 6 is at the right end. Bit 1 - Smoothing 0: Off, 1: On (Smoothing is disabled in halftone mode.) Bit 2 - CIL printing 0: On, 1: Off Bit 3 - Not used Bit 4 - mm/inch conversion 0: Off, 1: On Bit 5 - Engine type 0: mm, 1: inches Bit 6 - Document resolution unit 0: mm, 1: inches |

| System Switch 01 | | |
|-------------------------|---|---|
| No | FUNCTION | COMMENTS |
| 0 | Automatic Service Call at PM 0: Disabled 1: Enabled | This bit switch determines whether the machine will send an Auto Service Call to the service station when it is time for PM. Cross reference Auto service calls: Section 2.1 |
| 1-7 | Not used | Do not change the settings. |

| System Switch 02 | | |
|-------------------------|---|--|
| No | FUNCTION | COMMENTS |
| 0-3 | Not used | Do not change the settings. |
| 4 | File retention time 0: Depends on User Parameter 24 [18(H)] 1: No limit | 1: A file that had a communication error will not be erased unless the communication is successful. |
| 5 | Not used | Do not change the settings. |
| 6 7 | Memory read/write by RDS Bit 7 6 Setting 0 0 Always disabled 0 1 User selectable 1 0 User selectable 1 1 Always enabled | (0,0): All RDS systems are always locked out. (0,1), (1,0): Normally, RDS systems are locked out, but the user can temporarily switch RDS on to allow RDS operations to take place. RDS will automatically be locked out again after a certain time, which is stored in System Switch 03. Note that if an RDS operation takes place, RDS will not switch off until this time limit has expired. (1,1): At any time, an RDS system can access the machine. |

| System Switch 03 | | |
|-------------------------|---|--|
| No | FUNCTION | COMMENTS |
| 0 to 7 | Length of time that RDS is temporarily switched on when bits 6 and 7 of System Switch 02 are set to "User selectable" | 00 - 99 hours (BCD). This setting is only valid if bits 6 and 7 of System Switch 02 are set to "User selectable". The default setting is 24 hours. |

| System Switch 04 | | |
|-------------------------|---|--|
| No | FUNCTION | COMMENTS |
| 0-2 | Not used | Do not change the settings. |
| 3 | Printing dedicated tx parameters on Quick/Speed Dial Lists 0: Disabled 1: Enabled | 1: Each Quick/Speed dial number on the list is printed with the dedicated tx parameters (8 bytes each). The last 10 bytes of data are the programmed dedicated tx parameters; 32 bytes of data are printed (the other 22 bytes have no use for service technicians). |
| 4 | Not used | Do not change the settings. |

| System Switch 04 | | |
|-------------------------|--|--|
| No | FUNCTION | COMMENTS |
| 5 | Memory file transfer operation 0: User level 1: Service level | If the machine is unable to print fax messages due to a mechanical problem, change this bit to 0 to transfer all messages in the memory (including confidential rx messages) to an another terminal. Always reset this bit to 1 after transfer. However, this bit can be left at 0, if the customer's key-operators want to transfer the files themselves. Procedure 1. Enter service mode and change this bit to 0. 2. Exit the service mode. 3. Enter the key-operator mode, and select 'Key-operator settings'. 4. Choose '03' and specify a destination for the machine to transfer all the files to. 5. Press 'Start'. 6. After the machine transfers the memory files, enter the service mode and reset this bit to 1. Otherwise, anybody who knows how to enter the key-operator mode can transfer confidential messages. |
| 6 | G3 CSI/G4 Terminal ID programming level 0: User level 1: Service level | 1: The CSI and Terminal ID can only be programmed by a technician (in the user tools). The Terminal ID can only be programmed if a Group 4 option is installed. |
| 7 | Telephone line type programming mode 0: User level 1: Service level | 1: Telephone line type selection (choosing tone dial or pulse dial) can only be programmed by a technician (in the user tools). |

| System Switch 05 | | |
|-------------------------|---|---|
| No | FUNCTION | COMMENTS |
| 0-1 | Not used | Do not change the settings. |
| 2 | Display of both RTI and CSI on the LCD 0: Disabled 1: Enabled | 1: An RTI will be displayed until phase B of the protocol sequence, and a CSI will be displayed after phase C. |
| 3-7 | Not used | Do not change the settings. |

| System Switch 06 | | |
|-------------------------|---|--|
| No | FUNCTION | COMMENTS |
| 0 to 7 | Margin setting for Create Margin Transmission | 71 to 99 (BCD) %. This setting determines the reduction ratio when the user uses the Create Margin Transmission option. Default setting:1001 0011 (93%) |

| |
|--|
| System Switch 07 - Not used (Do not change the factory settings.) |
| System Switch 08 - Not used (Do not change the factory settings.) |

| System Switch 09 | | |
|-------------------------|---|---|
| No | FUNCTION | COMMENTS |
| 0 | Addition of image data from confidential transmissions on the transmission result report 0: Disabled 1: Enabled | If this feature is enabled, the top half of the first page of confidential messages will be printed on transmission result reports. |
| 1 | Inclusion of communications on the Journal when no image data was exchanged. 0: Disabled 1: Enabled | 0: Communications that reached phase C (message tx/rx) of the T.30 protocol are listed on the Journal. 1: Communications that reached phase A (call setup) of T.30 protocol are listed on the Journal. This will include telephone calls. |
| 2 | Automatic error report printout 0: Disabled 1: Enabled | 0: Error reports will not be printed. 1: Error reports will be printed automatically after failed communications. |
| 3 | Printing of the error code on the error report 0: No 1: Yes | 1: Error codes are printed on the error reports. |
| 4 | Not used | Do not change the settings. |
| 5 | Power failure report 0: Disabled 1: Enabled | 1: A power failure report will be automatically printed after the power is switched on if a fax message disappeared from the memory when the power was turned off last. |
| 6 | Conditions for printing the protocol dump list 0: Print for all communications 1: Print only when there is a communication error | This switch becomes effective only when system switch 00 bit 6 is set to 1. 1: Set this bit to 1 when you wish to print a protocol dump list only for communications with errors. |
| 7 | Priority given to various types of remote terminal ID when printing reports 0: RTI > CSI > Dial label > Tel. number 1: Dial label > Tel. number > RTI > CSI | This bit determines which set of priorities the machine uses when listing remote terminal names on reports. In G4 communication, G4_TID (Terminal ID) is used instead of RTI or CSI. (G4 is for the Europe model only.) Dial Label: The name stored, by the user, for the Quick/Speed Dial number. |

| System Switch 0A | | |
|-------------------------|--|---|
| No | FUNCTION | COMMENTS |
| 0-2 | Not used | Do not change the settings. |
| 3 | Continuous polling reception 0: Disabled 1: Enabled | This feature allows a series of stations to be polled in a continuous cycle. This will continue until the polling reception file is erased. The dialing interval is the same as memory transmission. |
| 4 | Dialing on the ten-key pad when the external telephone is off-hook 0: Disabled 1: Enabled | 0: Prevents dialing from the ten-key pad while the external telephone is off-hook. Use this setting when the external telephone is not by the machine, or if a wireless telephone is connected as an external telephone. 1: The user can dial on the machine's ten-key pad when the handset is off-hook. |
| 5 | On hook dial 0: Disabled 1: Enabled | 0: On hook dial is disabled. |
| 6 | Line used for G3 transmission 0: PSTN 1: ISDN ISDN: Europe model only | If an ISDN unit has been installed, this bit determines whether G3 transmissions go out over the PSTN or the ISDN. |
| 7 | Line used when the machine falls back to G3 from G4 if the other end is not a G4 machine 0: PSTN 1: ISDN ISDN: Europe model only | This bit switch has no effect if Communication Switch 07 bit 0 is set to 0. |

| |
|--|
| System Switch 0B - Not used (Do not change the factory settings.) |
| System Switch 0C - Not used (Do not change the factory settings.) |
| System Switch 0D - Not used (Do not change the factory settings.) |

| System Switch 0E | | |
|-------------------------|---|---|
| No | FUNCTION | COMMENTS |
| 0-2 | Not used | Do not change the settings. |
| 3 | Action when the external handset goes off-hook 0: Manual tx and rx operation 1: Memory tx and rx operation (the display remains the same) | 0: Manual tx and rx are possible while the external handset is off-hook. But, memory tx is not possible. 1: The display stays in standby mode even when the external handset is used, so that other people can use the machine for memory tx operation. Note that manual tx and rx are not possible with this setting. |
| 4-7 | Not used | Do not change the settings. |

| System Switch 0F | | |
|-----------------------------------|--|--|
| No | FUNCTION | COMMENTS |
| 0 to 7 | Country code for functional settings (Hex) 00: France 10: Not used 01: Germany 11: USA 02: UK 12: Asia 03: Italy 13: Japan 04: Austria 14: Hong Kong 05: Belgium 15: South Africa 06: Denmark 16: Australia 07: Finland 17: New Zealand 08: Ireland 18: Singapore 09: Norway 19: Malaysia 0A: Sweden 1A: China 0B: Switz. 1B: Taiwan 0C: Portugal 20: Turkey 0D: Holland 21: Greece 0E: Spain 0F: Israel | This country code determines the factory settings of bit switches and RAM addresses. However, it has no effect on the NCU parameter settings and communication parameter RAM addresses. Cross reference NCU country code: Function 06, parameter C.C. |

| System Switch 10 | | |
|-----------------------------------|---|---|
| No | FUNCTION | COMMENTS |
| 0 to 7 | Threshold memory level for parallel memory transmission | Threshold = N x 128 kbytes + 256 kbytes N can be between 00 - FF(H) Default setting: 02(H) = 512 kbytes |

| System Switch 11 | | |
|------------------|--|---|
| No | FUNCTION | COMMENTS |
| 0 | TTI printing position 0: Superimposed on the page data 1: Printed before the data leading edge | Change this bit to 1 if the TTI overprints information that the customer considers to be important (G3 transmissions). |
| 1 | TSI (G3) or CIL/TID (G4) printing position 0: Superimposed on the page data 1: Printed before the data leading edge | Change this bit to 1 if the TSI (G3) or CIL/TID (G4) overprints information that the customer considers to be important. G4: Europe model only |
| 2 | Not used | Do not change the factory settings. |
| 3 | TTI used for broadcasting 0: The TTIs selected for each Quick/Speed dial are used 1: The same TTI is used for all destinations | 1: The TTI (TTI_1 or TTI_2) which is selected with user switch 01 bit 6 is used for all destinations during broadcasting. |

| System Switch 11 | | |
|-------------------------|---|---|
| No | FUNCTION | COMMENTS |
| 4 | Type of TTI used for transmission using the ten-key pad 0: TTI_1 1: TTI_2 | 1: The machine uses TTI_2 when the user dials the destination using the ten-key pad. It is also used for polling transmission and manual transmission using the handset. |
| 5-6 | Not used | Do not change the factory settings. |
| 7 | Use of parallel memory transmission with G4 transmission 0: Disabled 1: Enabled G4: Europe model only | This determines whether parallel transmission can be used with a G4 transmission or not. Note that this bit is only effective if Parallel Memory transmission is enabled (User Parameter 07 - bit 2). |

| System Switch 12 | | |
|-------------------------|--|---|
| No | FUNCTION | COMMENTS |
| 0 to 7 | TTI/CIL printing position in the main scan direction CIL: Command Information Line (Group 4) G4: Europe model only | TTI/CIL: 08 to 64 (BCD) mm Input even numbers only. This setting determines the print start position for the TTI and CIL from the left edge of the paper. If the TTI is moved too far to the right, it may overwrite the file number which is on the top right of the page. On an A4 page, if the CIL is moved over by more than 60 mm, it may overwrite the page number. |

System Switch 13 - Not used (do not change the settings)

System Switch 14 - Not used (do not change the settings)

| System Switch 15 | | |
|-------------------------|--|---|
| No | FUNCTION | COMMENTS |
| 0 | Not used | Do not change the settings. |
| 1 | Going into the Night mode automatically 0: Enabled 1: Disabled | 1: The machine will restart from the Energy Saver mode quickly, because the +5V power supply is active even in the Energy Saver mode. |
| 2 | Protocol dump data backup 0: Disabled 1: Enabled | 1: The machine backs up the protocol dump data for approximately one hour when the main switch is turned off, in the same way as image data. |
| 3-7 | Not used | Do not change the settings. |

| System Switch 16 | | |
|-------------------------|--|--|
| No | FUNCTION | COMMENTS |
| 0 | Parallel Broadcasting 0: Disabled 1: Enabled | 1: When the G4 unit is installed, the machine sends messages simultaneously using both available ports (PSTN/ISDN) for broadcasting, if the job contains both PSTN and ISDN destinations. This is available for the European model only. |
| 1-7 | Not used | Do not change the settings. |



| |
|---|
| System Switch 17 - Not used (do not change the settings) |
| System Switch 18 - Not used (do not change the settings) |

| System Switch 19 | | |
|-------------------------|--|---|
| No | FUNCTION | COMMENTS |
| 0 to 2 | Key acknowledgement tone volume adjustment 000 (Min.: OFF)- 111 (Max.) Default setting – 011 | This controls the volume of this tone when the machine is in fax mode (it has no effect on the tone when the machine is in copier or printer mode). |
| 3-6 | Not used | Do not change the settings. |
| 7 | Special Original mode 0: Disabled 1: Enabled | 1: If the customer frequently wishes to transmit a form or letterhead which has a colored or printed background, change this bit to “1”. “Special Original” can be selected in addition to the “Text”, “Text/Photo” and “Photo” modes. When this mode is selected, the “Text/Photo” and “Photo” LEDs are both lit. Cross reference <input type="checkbox"/> Type of special original mode – Scanner switch 00 bit 0. |

| |
|---|
| System Switch 1A - Not used (do not change the settings) |
| System Switch 1B - Not used (do not change the settings) |

| System Switch 1C | | |
|-------------------------|--|---|
| No | FUNCTION | COMMENTS |
| 0 | PC-Fax Expander option 0: Not installed 1: Installed | Change this bit to 1 when installing the PC-Fax Expander. |
| 1 | To omit the PSTN access code during a PC-Fax transmission 0: Disabled 1: Enabled | 1: The machine does not dial the PSTN access code programmed in the PC-Fax application during PC-Fax memory transmission. This function becomes effective only when the PC fax application dials using a Quick/Speed/Group Dial stored in the fax machine. The machine will not omit dialing the PSTN access code when a destination number is programmed manually. |
| 2 | Not used | Do not change the settings. |
| 3 | Deleting the file when an error occurs during PC data storage to the SAF 0: Not cleared 1: Cleared | This function is effective for PC memory transmission. 0: The pages stored in the SAF will be transmitted from the machine. 1: All data is cleared when an error occurs. However, if the SAF memory becomes full during data storage, the setting of system bit switch 1E bit 1 determines how data is treated. This function is also effective for PC printing. |
| 4 | Resolution unit used for PC-Fax communication 0: mm 1: inches | This bit determines the resolution unit used for PC fax communication. This is because the PC fax application cannot automatically adjust the resolution unit. This setting is also effective for PC scanning. |
| 5-6 | Not used | Do not change the settings. |
| 7 | PC protocol dump list output after each PC communication 0: Off 1: On | 1: This is only used for PC communication troubleshooting. <input type="checkbox"/> Communications between the DIU (PCFE board) and a host PC are logged on the PC dump list. The setting of system switch 09 bit 6 determines the types of communication that the list is printed after. <input type="checkbox"/> PC scan and PC print are printed on the Journal. <input type="checkbox"/> The Data-in LED turns on while data is coming in and going out to the PC. Be sure to reset this bit to "0" after a test. |

System Switch 1D - Not used (do not change the settings)

| System Switch 1E | | |
|-------------------------|---|---|
| No | FUNCTION | COMMENTS |
| 0 | Communication after the Journal data storage area has become full 0: Possible 1: Impossible | This setting is effective only when Automatic Journal printout is enabled. 0: If the buffer memory of the communication records for the Journal is full, fax communications are still possible. But the machine will overwrite the oldest communication records. 1: If the buffer memory of the communication records for the Journal has become full, fax communications will become impossible, to prevent overwriting the communication records before the machine prints them out. Cross Reference <input type="checkbox"/> Automatic Journal output - User switch 03 bit 7 <input type="checkbox"/> Number of communication records for the Journal: 100 records (standard) 900 records (with the EXMEM board installed) |
| 1 | Action when the SAF memory has become full during scanning 0: The current page is erased. 1: The entire file is erased. | 0: If the SAF memory becomes full during scanning, the successfully scanned pages are transmitted. 1: If the SAF memory becomes full during scanning, the file is erased and no pages are transmitted. Not applicable to parallel memory transmission |
| 2 | RTI/CSI display priority 0: RTI 1: CSI | This bit determines which identifier, RTI or CSI, is displayed on the LCD while the machine is communicating in G3 non-standard mode. |
| 3 | File No. printing 0: Enabled 1: Disabled | 1: File numbers are not printed on any reports. |
| 4 | Action when authorized reception is enabled but authorized RTIs/CSIs are not yet programmed: 0: All fax reception is disabled 1: Faxes can be received if the sender has an RTI or CSI | If authorized reception is enabled but the user has stored no acceptable sender RTIs or CSIs, the machine will not be able to receive any fax messages. If the customer wishes to set up the authorized reception feature in this way, change this bit to "1" before enabling Authorized Reception. Messages from senders that include an RTI or CSI will be received. Otherwise, keep this bit at "0 (default setting)". |
| 5 | Address display priority in the AI redial mode. 0: RTI/CSI 1: Telephone number | 0: When the machine has both RTI/CSI and the telephone number information, the machine displays RTI/CSI. 1: The machine always displays the telephone number. |
| 6 | Not used | Do not change the settings |

| System Switch 1E | | |
|-------------------------|---|---|
| No | FUNCTION | COMMENTS |
| 7 | RAM initialization after the optional EXFUNC board is installed or removed 0: Enabled 1: Disabled | <p>When the machine detects that an EXFUNC board has been installed or removed, the machine shows the following message on the display for the customer.</p> <p><i>“Adding/Removing FAX Feature Expander causes data loss. Turn Main Power Switch off and remove/replace it to avoid loss. To continue, press Yes.”</i></p> <p>If Yes is pressed, the machine initializes the RAM to the “with” or “without card” configuration. However, changing this bit to ‘1’ disables this initialization, even if Yes is pressed.</p> <p>Change this bit to 1 after installing the EXFUNC board.</p> <p>0: When the above message is displayed, the machine initializes the RAM if Yes is pressed. The amount of data lost depends on whether the board is in or out. To avoid losing data, the user must switch off immediately and put the board back in.</p> <p>1: When the above message is displayed, the machine does not initialize the RAM even if Yes is pressed. However, the fax unit cannot be used until the user switches off, puts the board back in, then switches back on. No data is lost.</p> |

| System Switch 1F | | |
|-------------------------|---|---|
| No | FUNCTION | COMMENTS |
| 0 | Not used | Do not change the settings. |
| 1 | Report printout after an original jam during SAF storage or if the SAF memory fills up 0: Enabled 1: Disabled | 0: When an original jams, or the SAF memory overflows during scanning, a report will be printed. Change this bit to "1" if the customer does not want to have report in these cases. Memory tx – Memory storage report Parallel memory tx – Transmission result report |
| 2 | Not used | Do not change the settings. |
| 3 | Received fax print start timing (G3 reception) 0: After receiving each page 1: After receiving all pages | 0: The machine prints each page immediately after the machine receives it. 1: The machine prints the complete message after the machine receives all the pages in the memory. |
| 4 | Received fax print start timing (G4 reception) 0: After receiving each page 1: After receiving all pages | |
| 5-6 | Not used | Do not change the factory settings. |
| 7 | Action when a fax SC has occurred 0: Automatic reset 1: SC code display | 0: When the fax unit detects a fax SC code other than SC1201, the fax unit automatically resets itself. 1: When the fax unit detects any fax SC code, the fax unit displays the SC code and stops. Cross Reference Fax SC codes - See "Troubleshooting" |

4.2.2 SCANNER SWITCHES

| Scanner Switch 00 | | |
|-------------------|--|--|
| No | FUNCTION | COMMENTS |
| 0 | Type of special original mode 0: Monotone background 1: Colored background | This setting determines the scanner parameters used for special original mode. 0: This setting is for originals with random background of constant density, such as seen on banknotes (faxing banknotes is not recommended!). 1: This setting is for originals with background of constant density, such as those made on coloured paper. This switch becomes effective only when system switch 19 bit 7 is set to 1. |
| 1-3 | Not used | Do not change the settings. |
| 4 | OR processing (Text mode) 0: Disabled 1: Enabled | 1: Each pair of scan lines goes through OR processing before transmission. |
| 5-7 | Not used | Do not change the settings. |

| Scanner Switch 01 | | |
|-------------------|-------------------------------------|---|
| No | FUNCTION | COMMENTS |
| 0 to 4 | Scan density step value (Text mode) | When scan density is adjusted manually away from the Normal setting, the threshold value for binary picture processing changes for each step from the value specified by Scanner Switch 02, by the amount programmed here. For example, with the default setting (14), the threshold value changes as follows. +3 (Darkest) : 77 (= 91 - 14) +2 : 91 (= 105 - 14) +1 : 105 (= 119 - 14) 0 (Normal) : 119 (Scanner Switch 02 setting) -1 : 133 (= 119 + 14) -2 : 147 (= 133 + 14) -3 (Lightest) : 161 (= 147 + 14) The value can be between 00 and 1F(H) [= 31(D)]. For a darker threshold, input a lower value. |
| 5-7 | Not used. | Do not change the settings. |

| Scanner Switch 02 | | |
|-------------------|---|---|
| No | FUNCTION | COMMENTS |
| 0 to 7 | Binary picture processing: Threshold for Text mode - Normal setting (center position) | This setting determines the threshold value for binary picture processing in Text mode (when the scan density setting is at the center). The value can be between 01 and FF. For a darker threshold, input a lower value. Default setting: 77(H) = 119(D) |

| Scanner Switch 03 | | |
|--------------------------|---|--|
| No | FUNCTION | COMMENTS |
| 0 to 7 | Binary picture processing: Threshold for Photo and Text/Photo mode - Normal setting (center position) | This setting determines the threshold value for binary picture processing in Text/Photo mode (when the scan density setting is at the center). The value can be between 01 and FF. For a darker threshold, input a lower value. Default setting: 23(H) = 35(D) |

| |
|--|
| Scanner Switch 04 - Not used (do not change the settings) |
| Scanner Switch 05 - Not used (do not change the settings) |

| Scanner Switch 06 | | |
|--------------------------|--|-----------------|
| No | FUNCTION | COMMENTS |
| 0 to 3 | MTF filter level (Text mode) The value can be between 0(Off) and F. For a weaker threshold, input a lower value. Default setting: 7 This setting is independent from the threshold specified by copier SP mode 4-916. | |
| 4 to 7 | MTF filter level (Text/Photo mode) The value can be between 0(Off) and F. For a weaker threshold, input a lower value. Default setting: 7 This setting is independent from the threshold specified by copier SP mode 4-916. | |

| Scanner Switch 07 | | |
|--------------------------|-------------------------------------|--|
| No | FUNCTION | COMMENTS |
| 0 to 2 | Smoothing filter level (Photo mode) | The value can be between 0(Off) and 7. For a weaker threshold, input a lower value. Default setting: 2 This setting is independent from the threshold setting specified by the copier's SP mode 4-927. |
| 3-7 | Not used | Do not change the settings. |

| |
|--|
| Scanner Switch 08 - Not used (do not change the settings) |
| Scanner Switch 09 - Not used (do not change the settings) |

| Scanner Switch 0A | | |
|--------------------------|---|---|
| No | FUNCTION | COMMENTS |
| 0 to 2 | Isolated dot elimination level (Text modes) | The value can be between 0(Off) and 4. For a higher threshold, input a higher value. Default setting: 2 This setting is independent from the threshold setting specified by the copier's SP mode 4-917. |
| 3-7 | Not used | Do not change the settings. |

| Scanner Switch 0B | | |
|-------------------|---|-----------------------------|
| No | FUNCTION | COMMENTS |
| 0 to 3 | Scan margin setting (top and bottom margin in book scan mode, and top margin in ADF mode) The setting can be between 0 and F (H) (in mm). Default setting: 3 mm If the scanned image margin is still incorrect after adjustment, the base copier's SP mode settings may be incorrect. Check and adjust SP modes 4-012-1 and 6-006-2. | |
| 4 to 6 | Scan margin setting (bottom margin in ADF mode) The setting can be between 0 and 7 (H) (in mm). Default setting: 2 mm If the scanned image margin is still incorrect after adjustment, the base copier's SP mode settings may be wrong. Check and adjust SP modes 4-012-1 and 6-006-2. | |
| 7 | Not used | Do not change the settings. |

| Scanner Switch 0C | | |
|-------------------|---|---|
| No | FUNCTION | COMMENTS |
| 0 | Action when an original jam has occurred while scanning the original into memory for memory tx 0: Continues scanning after recovery 1: Stops scanning and erases all scanned pages for that job | This bit is only effective when parallel memory tx is disabled (user parameter 07 - bit 2). If parallel memory tx is enabled, the machine always erases the scanned pages when an original jam occurs. The machine then asks the user to retry from the first page, even if the parallel memory tx is not actually used. 0: The machine displays a message asking the user to put the jammed page back into the original stack, and continues scanning. The message is displayed for the time period specified by scanner switch 0E, bit 2. 1: The machine erases all the scanned pages and asks the user to retry from the first page. |
| 1 to 2 | Setting when an original size cannot be recognized Bit 2 1 Setting 0 0 Depending on the copier's setting 0 1 A5 <input type="checkbox"/> 1 0 A5 <input type="checkbox"/> 1 1 No original | When both bits are set to "0", the machine recognizes an original size depending on SP4-303 copier's service mode. |
| 3-5 | Not used | Do not change the settings. |
| 6 | Scan width used for a document set in the ADF when the width is less than 230 mm. 0: A4 (210 mm), 1: LT (216 mm) | This bit is set at "1" when the country code is set to the US. |
| 7 | Not used | Do not change the settings. |

| Scanner Switch 0D | | |
|-------------------|---|---|
| No | FUNCTION | COMMENTS |
| 0 1 | Scan magnification ratio fine tuning (Main scan direction) $\begin{pmatrix} 0 \\ 0 \end{pmatrix} = 0\%$, $\begin{pmatrix} 1 \\ 0 \end{pmatrix} = -1.5\%$, $\begin{pmatrix} 0 \\ 1 \end{pmatrix} = +1.5\%$, $\begin{pmatrix} 1 \\ 1 \end{pmatrix} =$ Do not use this setting The actual magnification ratio is the sum of the SP mode 4-008 setting and this setting. | |
| 2 3 | Scan magnification ratio fine tuning (Sub scan direction) $\begin{pmatrix} 0 \\ 0 \end{pmatrix} = 0\%$, $\begin{pmatrix} 1 \\ 0 \end{pmatrix} = -1.5\%$, $\begin{pmatrix} 0 \\ 1 \end{pmatrix} = +1.5\%$, $\begin{pmatrix} 1 \\ 1 \end{pmatrix} =$ Do not use this setting The actual magnification ratio is the sum of the SP mode 4-101 setting and this setting. | |
| 4-6 | Not used | Do not change the settings. |
| 7 | Scan width for A5 lengthwise or B5 lengthwise originals 0: 210 mm (8.5") 1: Original width | 0: The machine scans the original as 210 mm (8.5") width. The transmitted image has a blank area on the right. 1: The machine scans 148 mm (A5) or 182 mm (B5) and centers the scanned data on a 216 mm width transmitted image. |

| Scanner Switch 0E | | |
|-------------------|---|--|
| No | FUNCTION | COMMENTS |
| 0 | Wait time for the next page when scanning a book original into memory 0: 60 s 1: 30 s | This bit determines how long the machine waits for the next page when scanning a book original for memory transmission. If this timer expires, the machine transmits all the pages scanned so far as one document. Note: In immediate tx or parallel memory tx, the wait time for the next page is 10 s. |
| 1 | Scan resolution unit (except standard resolution in book scan mode) 0: mm 1: inches | This bit determines which resolution unit will be used for scanning a fax message. Default setting: mm |
| 2 | ADF jam alarm display time 0: 60 s 1: 30 s | The bit is only effective when bit 0 of scanner bit switch 0C is '0'. This bit determines how long the machine displays the ADF jam alarm after a jam occurred. |
| 3-7 | Not used | Do not change the settings. |

| Scanner Switch 0F | | |
|--------------------------|---|--|
| No | FUNCTION | COMMENTS |
| 0 | Image rotation before transmission (A4/LT sideways) 0: Disabled 1: Enabled | This bit determines whether the machine rotates the scanned image by 90 degrees before transmission. If this bit is set at 1, A4 (LT) sideways images (297 mm width in the protocol) will be transmitted as A4 (LT) lengthwise images (216 mm width in the protocol). Refer to Image Rotation Before Transmission in chapter 2 for more details. |
| 1 | Not used | Do not change the settings |
| 2 | Image rotation before transmission (A5/HLT lengthwise) 0: Disabled 1: Enabled | This bit determines whether the machine rotates the scanned image by 90 degrees before transmission. If this bit is set at "1", A5 (HLT) lengthwise images will be transmitted as A4 (LT) width images (216 mm width in the protocol). Refer to Image Rotation Before Transmission in chapter 2 for more details. |
| 3-7 | Not used | Do not change the settings. |

4.2.3 PRINTER SWITCHES

| Printer Switch 00 | | |
|-------------------|---|--|
| No | FUNCTION | COMMENTS |
| 0 | Page separation mark 0: Disabled 1: Enabled | 0: No marks are printed. 1: If a received page has to be printed out on two sheets, an asterisk inside square brackets is printed at the bottom right hand corner of the first sheet, and a "2" inside a small box is printed at the top right hand corner of the second sheet. This helps the user to identify pages that have been split. |
| 1 | Repetition of data when the received page is longer than the printer paper 0: Disabled 1: Enabled | 0: The next page continues from where the previous page left off. 1: The final few mm of the previous page are repeated at the top of the next page. The amount of repeated data depends on printer switch 04, bits 5 and 6. See Sub Scan Reduction and Page Separation in section 2 for details. |
| 2 | Prints the date and time on received fax messages 0: Disabled 1: Enabled | This switch is only effective when user parameter 02 - bit 2 (printing the received date and time on received fax messages) is enabled. 1: The machine prints the received and printed date and time at the bottom of each received page. |
| 3-7 | Not used | Do not change the settings. |

| Printer Switch 01 | | |
|-------------------|--|--|
| No | FUNCTION | COMMENTS |
| 0-2 | Not used | Do not change the settings. |
| 3 4 | Maximum print width used in the setup protocol $\begin{pmatrix} 0 \\ 0 \end{pmatrix} = \text{Not used}$ $\begin{pmatrix} 1 \\ 0 \end{pmatrix} = 297 \text{ mm}$ $\begin{pmatrix} 0 \\ 1 \end{pmatrix} = 254 \text{ mm}$ $\begin{pmatrix} 1 \\ 1 \end{pmatrix} = 216 \text{ mm}$ $\begin{pmatrix} 0 \\ 0 \end{pmatrix} = \text{Not used}$ $\begin{pmatrix} 1 \\ 0 \end{pmatrix} = 11.7 \text{ inch}$ $\begin{pmatrix} 0 \\ 1 \end{pmatrix} = 10.1 \text{ inch}$ $\begin{pmatrix} 1 \\ 1 \end{pmatrix} = 8.5 \text{ inch}$ | |
| 5-6 | Not used | Do not change the settings. |
| 7 | Received message width restriction in the protocol signal to the sender 0: Disabled 1: Enabled | 0: The machine informs the transmitting machine of the print width depending on the paper size available from the paper feed stations. Refer to the table on the next page for how the machine chooses the paper width used in the setup protocol (NSF/DIS). 1: The machine informs the transmitting machine of the fixed paper width which is specified by bits 3 and 4 above. |

Relationship between available paper sizes and printer width used in the setup protocol

| Available Paper Size | Printer width used in the Protocol (NSF/DIS) |
|--------------------------------|--|
| A4 or 8.5 x 11" | 297 mm width |
| B5 | 256 mm width |
| A5 or 8.5 x 5.5" | 216 mm width |
| No paper available (Paper end) | 216 mm width |

| Printer Switch 02 | | |
|-------------------|--|--|
| No | FUNCTION | COMMENTS |
| 0 | 1st paper feed station usage for fax printing 0: Enabled 1: Disabled | <p>0: The paper feed station can be used to print fax messages and reports.</p> <p>1: The specified paper feed station will not be used for printing fax messages and reports.</p> <p>Note: Do not disable usage for the paper feed station which has been specified by User Parameter Switch 0F (15), or which is used for the Specified Cassette Selection feature.</p> |
| 1 | 2nd paper feed station usage for fax printing 0: Enabled 1: Disabled | |
| 2 | 3rd paper feed station usage for fax printing 0: Enabled 1: Disabled | |
| 3-7 | Not used | Do not change the settings. |

| Printer Switch 03 | | |
|-------------------|--|---|
| No | FUNCTION | COMMENTS |
| 0 | Length reduction of received data 0: Disabled 1: Enabled | <p>0: Incoming pages are printed without length reduction. (Page separation threshold: Printer Switch 03, bits 4 to 7)</p> <p>1: Incoming page length is reduced when printing. (Maximum reducible length: Printer Switches 04, bits 0 to 4)</p> <p>Page separation and data reduction: Section 2</p> |
| 1-3 | Not used | Do not change the settings |

| | | | | | | | |
|---------------|---|---|---|---|---|---|----|
| 4 to 7 | <p>Page separation threshold (with reduction disabled with switch 03-0 above)</p> <p>If the incoming page is up to x mm longer than the length of copy paper, the excess portion will not be printed. If the incoming page is more than x mm longer than the length of copy paper, the excess portion will be printed on the next page. The value of x is determined by these four bits.</p> <p>Hex value of bits 4 to 7 x (mm)</p> <table style="margin-left: 40px;"> <tr><td>0</td><td>0</td></tr> <tr><td>1</td><td>1</td></tr> </table> <p>and so on until</p> <table style="margin-left: 40px;"> <tr><td>F</td><td>15</td></tr> </table> <p>Default setting: 6 mm</p> <p>Cross reference Page separation and data reduction: section 2 Length reduction On/Off: Printer Switch 03, Bit 0</p> | 0 | 0 | 1 | 1 | F | 15 |
| 0 | 0 | | | | | | |
| 1 | 1 | | | | | | |
| F | 15 | | | | | | |

| Printer Switch 04 | | | | | | | | | | | | | | | | | | | | | | | | | | | | | | | | | | | | | | | | | |
|-------------------|---|---|---|---|---|----------------------------|---|---|---|---|---|---------|--|---|---|---|---|---|------|--|---|---|---|---|---|------|--|---|---|---|---|---|-------------------------|--|---|---|---|---|---|--------|--|
| No | FUNCTION | | | | | COMMENTS | | | | | | | | | | | | | | | | | | | | | | | | | | | | | | | | | | | |
| 0 to 4 | <p>Maximum reducible length when length reduction is enabled with switch 03-0 above.</p> <p><Maximum reducible length> = <Paper length> + (N x 5mm) 'N' is the decimal value of the binary setting of bits 0 to 4.</p> <table style="margin-left: 20px;"> <tr><td>Bit</td><td>4</td><td>3</td><td>2</td><td>1</td><td>0</td><td>Setting</td></tr> <tr><td></td><td>0</td><td>0</td><td>0</td><td>0</td><td>0</td><td>0 mm</td></tr> <tr><td></td><td>0</td><td>0</td><td>0</td><td>0</td><td>1</td><td>5 mm</td></tr> <tr><td></td><td>0</td><td>0</td><td>1</td><td>0</td><td>0</td><td>20 mm (default setting)</td></tr> <tr><td></td><td>1</td><td>1</td><td>1</td><td>1</td><td>1</td><td>155 mm</td></tr> </table> <p>For A5 sideways and B5 sideways paper <Maximum reducible length> = <Paper length> + 0.75 x (N x 5mm)</p> | | | | | Bit | 4 | 3 | 2 | 1 | 0 | Setting | | 0 | 0 | 0 | 0 | 0 | 0 mm | | 0 | 0 | 0 | 0 | 1 | 5 mm | | 0 | 0 | 1 | 0 | 0 | 20 mm (default setting) | | 1 | 1 | 1 | 1 | 1 | 155 mm | |
| Bit | 4 | 3 | 2 | 1 | 0 | Setting | | | | | | | | | | | | | | | | | | | | | | | | | | | | | | | | | | | |
| | 0 | 0 | 0 | 0 | 0 | 0 mm | | | | | | | | | | | | | | | | | | | | | | | | | | | | | | | | | | | |
| | 0 | 0 | 0 | 0 | 1 | 5 mm | | | | | | | | | | | | | | | | | | | | | | | | | | | | | | | | | | | |
| | 0 | 0 | 1 | 0 | 0 | 20 mm (default setting) | | | | | | | | | | | | | | | | | | | | | | | | | | | | | | | | | | | |
| | 1 | 1 | 1 | 1 | 1 | 155 mm | | | | | | | | | | | | | | | | | | | | | | | | | | | | | | | | | | | |
| 5 to 6 | <p>Length of the duplicated image on the next page, when page separation has taken place.</p> <p>$\begin{pmatrix} 0 \\ 0 \end{pmatrix}$ = 4 mm $\begin{pmatrix} 1 \\ 0 \end{pmatrix}$ = 10 mm $\begin{pmatrix} 0 \\ 1 \end{pmatrix}$ = 15 mm $\begin{pmatrix} 1 \\ 1 \end{pmatrix}$ = Not used</p> | | | | | | | | | | | | | | | | | | | | | | | | | | | | | | | | | | | | | | | | |
| 7 | Not used. | | | | | Do not change the setting. | | | | | | | | | | | | | | | | | | | | | | | | | | | | | | | | | | | |

Printer Switch 05 - Not used (do not change the settings)

| Printer Switch 06 | | |
|--------------------------|---|--|
| No | FUNCTION | COMMENTS |
| 0 | Printing while a paper cassette is pulled out, when the Just Size Printing feature is enabled. 0: Printing will not start 1: Printing will start if another cassette has a suitable size of paper, based on the paper size selection priority tables. | Refer to Just Size Printing in section 2 for details. Cross reference Just size printing on/off – User switch 05, bit 5 |
| 1-7 | Not used. | Do not change the settings. |

| Printer Switch 07 | | |
|--------------------------|---|---|
| No | FUNCTION | COMMENTS |
| 0 | Reduction for Journal printing 0: Off 1: On | 1: The Journal is reduced to 91% to ensure that there is enough to space in the left margin for hole punches or staples. |
| 2-3 | Not used. | Do not change the settings. |
| 4 | List of destinations in the Communication Failure Report for broadcasting 0: All destinations 1: Only destinations where communication failure occurred | 1: Only destinations where communication failure occurred are printed on the Communication Failure Report. |
| 5-7 | Not used. | Do not change the settings. |

| |
|--|
| Printer Switch 08 - Not used (do not change the settings) |
| Printer Switch 09 - Not used (do not change the settings) |
| Printer Switch 0A - Not used (do not change the settings) |
| Printer Switch 0B - Not used (do not change the settings) |
| Printer Switch 0C - Not used (do not change the settings) |
| Printer Switch 0D - Not used (do not change the settings) |

| Printer Switch 0E | | |
|--------------------------|---|---|
| No | FUNCTION | COMMENTS |
| 0 | Paper size selection priority 0: Width 1: Length | 0: A paper size that has the same width as the received data is selected first. 1: A paper size which has enough length to print all the received lines without reduction is selected first. |
| 1 | Paper size selected for printing A4 width fax data 0: 8 x 11" size 1: A4 size | This switch determines which paper size is selected for printing A4 width fax data, when the machine has both A4 and 8" x 11" size paper. |

| | | |
|----------------------|---|--|
| <p>2</p> | <p>Page separation 0: Enabled 1: Disabled</p> | <p>1: If all paper sizes in the machine require page separation to print a received fax message, the machine does not print the message (Substitute Reception is used). After a larger size of paper is set in a cassette, the machine automatically prints the fax message.</p> |
| <p>3 to 4</p> | <p>Printing the sample image on reports Bit 4 Bit 3 Setting 0 0 The upper half only 0 1 50% reduction in sub-scan only 1 0 Same size 1 1 Not used</p> | <p>“Same size” means the sample image is printed at 100%, even if page separation occurs. User Parameter Switch 19 bit 4 must be set to “0” to enable this switch.</p> |
| <p>5-6</p> | <p>Not used</p> | <p>Do not change the settings.</p> |
| <p>7</p> | <p>Equalizing the reduction ratio among separated pages (Page Separation) 0: Enabled 1: Disabled</p> | <p>0: When page separation has taken place, all the pages are reduced with the same reduction ratio. 1: Only the last page is reduced to fit the selected paper size when page separation has taken place. Other pages are printed without reduction.</p> |

| <p>Printer Switch 0F</p> | | |
|---------------------------------|---|--|
| <p>No</p> | <p>FUNCTION</p> | <p>COMMENTS</p> |
| <p>0 to 1</p> | <p>Smoothing feature Bit 1 Bit 0 Setting 0 0 Disabled 0 1 Disabled 1 0 Enabled 1 1 Not used</p> | <p>(0, 0) (0, 1): Disable smoothing if the machine receives halftone images from other manufacturers fax machines frequently.</p> |
| <p>2-7</p> | <p>Not used</p> | <p>Do not change the settings.</p> |

4.2.4 COMMUNICATION SWITCHES

| Communication Switch 00 | | |
|-----------------------------------|---|---|
| No | FUNCTION | COMMENTS |
| 0 to 1 | Compression modes available in receive mode Bit 1 0 Modes 0 0 MH only 0 1 MH/MR 1 0 MH/MR/MMR 1 1 MH/MR/MMR/JBIG | These bits determine the compression capabilities to be declared in phase B (handshaking) of the T.30 protocol. |
| 2 to 3 | Compression modes available in transmit mode Bit 3 2 Modes 0 0 MH only 0 1 MH/MR 1 0 MH/MR/MMR 1 1 MH/MR/MMR/JBIG | These bits determine the compression capabilities to be used in the transmission and to be declared in phase B (handshaking) of the T.30 protocol. |
| 4 | Not used | Do not change the settings. |
| 5 | JBIG compression method: Reception 0 : Only basic supported 1 : Basic and optional both supported | Change the setting when communication problems occur using JBIG compression. |
| 6 | JBIG compression method: Transmission 0 : Basic mode priority 1 : Optional mode priority | Change the setting when communication problems occur using JBIG compression. |
| 7 | Closed network (reception) 0 : Disabled 1 : Enabled | 1 : Reception will not go ahead if the ID code of the other terminal does not match the ID code of this terminal. This function is only available in NSF/NSS mode. |

| Communication Switch 01 | | |
|-------------------------|-------------------------------------|--|
| No | FUNCTION | COMMENTS |
| 0 | ECM 0 : Off 1 : On | If this bit is set to 0, ECM is switched off for all communications. In addition, V.8 protocol and JBIG compression are switched off automatically. |
| 1 | Not used | Do not change the setting. |

| Communication Switch 01 | | | | | | | | | | | | | | | | | |
|-------------------------|---|---|----------------|--------------|----------------|---|---|----------|---|---|-------------|---|---|-------------|---|---|-------------|
| No | FUNCTION | COMMENTS | | | | | | | | | | | | | | | |
| 2 | Wrong connection prevention method | <p>(0,1) - The machine will disconnect the line without sending a fax message, if the last 8 digits of the received CSI do not match the last 8 digits of the dialed telephone number. This does not work when manually dialed.</p> <p>(1,0) - The same as above, except that only the last 4 digits are compared.</p> <p>(1,1) - The machine will disconnect the line without sending a fax message, if the other end does not identify itself with an RTI or CSI.</p> <p>(0,0) - Nothing is checked; transmission will always go ahead.</p> <p>Note: This function does not work when dialing is done from the external telephone.</p> | | | | | | | | | | | | | | | |
| 3 | <table border="0"> <tr> <td>Bit 3</td> <td>Bit 2</td> <td>Setting</td> </tr> <tr> <td>0</td> <td>0</td> <td>None</td> </tr> <tr> <td>0</td> <td>1</td> <td>8 digit CSI</td> </tr> <tr> <td>1</td> <td>0</td> <td>4 digit CSI</td> </tr> <tr> <td>1</td> <td>1</td> <td>CSI/RTI</td> </tr> </table> | | Bit 3 | Bit 2 | Setting | 0 | 0 | None | 0 | 1 | 8 digit CSI | 1 | 0 | 4 digit CSI | 1 | 1 | CSI/RTI |
| Bit 3 | Bit 2 | | Setting | | | | | | | | | | | | | | |
| 0 | 0 | | None | | | | | | | | | | | | | | |
| 0 | 1 | | 8 digit CSI | | | | | | | | | | | | | | |
| 1 | 0 | 4 digit CSI | | | | | | | | | | | | | | | |
| 1 | 1 | CSI/RTI | | | | | | | | | | | | | | | |
| 4-5 | Not used | Do not change the setting. | | | | | | | | | | | | | | | |
| 6 | Maximum printable page length available | <p>The setting determined by these bits is informed to the transmitting terminal in the pre-message protocol exchange (in the DIS/NSF frames).</p> | | | | | | | | | | | | | | | |
| 7 | <table border="0"> <tr> <td>Bit 7</td> <td>6</td> <td>Setting</td> </tr> <tr> <td>0</td> <td>0</td> <td>No limit</td> </tr> <tr> <td>0</td> <td>1</td> <td>B4 (364 mm)</td> </tr> <tr> <td>1</td> <td>0</td> <td>A4 (297 mm)</td> </tr> <tr> <td>1</td> <td>1</td> <td>A3 (432 mm)</td> </tr> </table> | | Bit 7 | 6 | Setting | 0 | 0 | No limit | 0 | 1 | B4 (364 mm) | 1 | 0 | A4 (297 mm) | 1 | 1 | A3 (432 mm) |
| Bit 7 | 6 | | Setting | | | | | | | | | | | | | | |
| 0 | 0 | | No limit | | | | | | | | | | | | | | |
| 0 | 1 | | B4 (364 mm) | | | | | | | | | | | | | | |
| 1 | 0 | A4 (297 mm) | | | | | | | | | | | | | | | |
| 1 | 1 | A3 (432 mm) | | | | | | | | | | | | | | | |

| Communication Switch 02 | | | | | | | | | | | | | | | | | | |
|-------------------------|--|--|-------------------|----------------|----------------|----------------|--|------------------|-----------------|------------------|--------------|---|----|----|---------------|----|----|----|
| No | FUNCTION | COMMENTS | | | | | | | | | | | | | | | | |
| 0 | Burst error threshold 0: Low 1: High | <p>If there are more consecutive error lines in the received page than the threshold, the machine will send a negative response.</p> <p>The Low and High threshold values depend on the sub-scan resolution, and are as follows.</p> <table border="0"> <tr> <td>Resolution</td> <td>100 dpi</td> <td>200 dpi</td> <td>400 dpi</td> </tr> <tr> <td></td> <td>3.85 l/mm</td> <td>7.7 l/mm</td> <td>15.4 l/mm</td> </tr> <tr> <td>Low settings</td> <td>6</td> <td>12</td> <td>24</td> </tr> <tr> <td>High settings</td> <td>12</td> <td>24</td> <td>48</td> </tr> </table> | Resolution | 100 dpi | 200 dpi | 400 dpi | | 3.85 l/mm | 7.7 l/mm | 15.4 l/mm | Low settings | 6 | 12 | 24 | High settings | 12 | 24 | 48 |
| Resolution | 100 dpi | 200 dpi | 400 dpi | | | | | | | | | | | | | | | |
| | 3.85 l/mm | 7.7 l/mm | 15.4 l/mm | | | | | | | | | | | | | | | |
| Low settings | 6 | 12 | 24 | | | | | | | | | | | | | | | |
| High settings | 12 | 24 | 48 | | | | | | | | | | | | | | | |
| 1 | Acceptable total error line ratio 0: 5% 1: 10% | If the error line ratio for a page exceeds the acceptable ratio, RTN will be sent to the other end. | | | | | | | | | | | | | | | | |
| 2 | Treatment of pages received with errors during G3 reception 0: Deleted from memory without printing 1: Printed | 0: Pages received with errors are not printed. | | | | | | | | | | | | | | | | |

| Communication Switch 02 | | |
|--------------------------------|--|---|
| No | FUNCTION | COMMENTS |
| 3 | Hang-up decision when a negative code (RTN or PIN) is received during G3 immediate transmission 0: No hang-up, 1: Hang-up | 0: The next page will be sent even if RTN or PIN is received. 1: The machine will send DCN and hang up if it receives RTN or PIN. This bit is ignored for memory transmissions or if ECM is being used. |
| 4-6 | Not used | Do not change the settings. |
| 7 | Method of total error rate calculation 0: Normal method 1: French PTT requirement | 0: Error rate is calculated by dividing the number of total lines by the number of error lines. 1: Error rate is calculated by dividing the number of total plus error lines by the number of error lines. |

| Communication Switch 03 | | |
|--------------------------------|--|--|
| No | FUNCTION | COMMENTS |
| 0 to 7 | Maximum number of page retransmissions in a G3 memory transmission | 00 - FF (Hex) times. This setting is not used if ECM is switched on. Default setting - 03(H) |

Communication Switch 04 - Not used (do not change the settings)

Communication Switch 05 - Not used (do not change the settings)

| Communication Switch 06 | | |
|--------------------------------|---|--|
| No | FUNCTION | COMMENTS |
| 0 | Dialing requirements: Germany 0: Disabled 1: Enabled | These switches are automatically set to the settings required by each country after the country code (System Switch 0F) is programmed. |
| 1 | Dialing requirements: Austria 0: Disabled 1: Enabled | |
| 2 | Dialing requirements: Norway 0: Disabled 1: Enabled | |
| 3 | Dialing requirements: Denmark 0: Disabled 1: Enabled | |
| 4 | Dialing requirements: France 0: Disabled 1: Enabled | |
| 5 | Dialing requirements: Switzerland 0: Disabled 1: Enabled | |
| 6 | Not used | Do not change the settings. |
| 7 | Carrier drop display 0: Disabled 1: Enabled | This is an European PTT requirement. This bit is available only for the European models. |

| Communication Switch 07 | | |
|--------------------------------|---|---|
| No | FUNCTION | COMMENTS |
| 0 | Fallback from G4 to G3 if the other terminal is not a G4 terminal 0: Disabled 1: Enabled G4: Europe model only | Also see system switch 0A bit 7. Refer to the ISDN G4 option service manual (G4 Internal Switches 17, 18, 1A, 1B, and 1C) for the CPS code set (Cause Value set) that determines G4 to G3 fallback. |
| 1 | Not used | Do not change the setting. |
| 2 | Use of the date and time provided from the network for the CIL 0: Disabled 1: Enabled G4: Europe model only | 0: The date and time programmed in the receiving terminal is used in the CIL. 1: The date and time informed in the document layer from the remote terminal (through the network) is used in the CIL. |
| 3 | Fallback from G4 to G3 reflected in programmed Quick/Speed dials 0: Fallback enabled 1: Always start with G4 G4: Europe model only | 0: If a communication falls back from G4 to G3, the machine will always start transmission with G3 from the next communication. 1: The machine will always start to transmit with G4. |
| 4 | Fallback from G4 to G3 when G4 communication fails on the ISDN B-channel 0: Fallback disabled 1: Fallback enabled | 1: Enable this switch only when G4 communication errors occur because the exchanger connects G4 calls to the PSTN. This problem occurs with some types of exchanger. (Europe model only) |
| 5-7 | Not used | Do not change the settings. |

Communication Switch 08 - Not used (do not change the settings)

Communication Switch 09 - Not used (do not change the settings)

| Communication Switch 0A | | |
|--------------------------------|---|--|
| No | FUNCTION | COMMENTS |
| 0 | Point of resumption of memory transmission upon redialing 0: From the error page 1: From page 1 | 0: The transmission begins from the page where transmission failed the previous time. 1: Transmission begins from the first page, using normal memory transmission. |
| 1-6 | Not used | Do not change the settings. |
| 7 | Emergency calls using 999 0: Enabled 1: Disabled | If this bit is at 1, the machine will not allow you to dial 999 at the auto-dialer. This is a PTT requirement in the UK and some other countries. |

Communication Switch 0B - Not used (do not change the settings)

Communication Switch 0C - Not used (do not change the settings)

| Communication Switch 0D | | |
|--------------------------------|---|---|
| No | FUNCTION | COMMENTS |
| 0 to 7 | The available memory threshold, below which ringing detection (and therefore reception into memory) is disabled | 00 to FF (Hex), unit = 4 kbytes (e.g., 06(H) = 24 kbytes) One page is about 24 kbytes. The machine refers to this setting before each fax reception. If the amount of remaining memory is below this threshold, the machine cannot receive any fax messages. If this setting is kept at 0, the machine will detect ringing signals and go into receive mode even if there is no memory available. This will result in communication failure. |

| Communication Switch 0E | | |
|--------------------------------|---|--|
| No | FUNCTION | COMMENTS |
| 0 to 7 | Minimum interval between automatic dialing attempts | 06 to FF (Hex), unit = 2 s (e.g., 06(H) = 12 s) This value is the minimum time that the machine waits before it dials the next destination. |

| Communication Switch 0F | | |
|--------------------------------|---|---|
| No | FUNCTION | COMMENTS |
| 0 to 7 | Minimum number of times that a destination will dialed when TRD is being used | 01 - FE (Hex) times TRD: Transmission Deadline |

| Communication Switch 10 | | |
|--------------------------------|---|---------------------|
| No | FUNCTION | COMMENTS |
| 0 to 7 | Memory transmission: Maximum number of dialing attempts to the same destination | 01 - FE (Hex) times |

Communication Switch 11 - Not used (do not change the settings.)

| Communication Switch 12 | | |
|--------------------------------|--|-----------------------|
| No | FUNCTION | COMMENTS |
| 0 to 7 | Memory transmission: Interval between dialing attempts to the same destination | 01 - FF (Hex) minutes |

Communication Switch 13 - Not used (do not change the settings.)

| Communication Switch 14 | | |
|-------------------------|--|--|
| No | FUNCTION | COMMENTS |
| 0 | Inch-to-mm conversion during transmission 0: Disabled 1: Enabled | 0: In immediate transmission, data scanned in inch format are transmitted without conversion. In memory transmission, data stored in the SAF memory in mm format are transmitted without conversion. Note: When storing the scanned data into SAF memory, the fax unit always converts the data into mm format. 1: The machine converts the scanned data or stored data in the SAF memory to the format which was specified in the set-up protocol (DIS/NSF) before transmission. |
| 1-5 | Not used | Do not change the factory settings. |
| 6 7 | Available unit of resolution in which fax messages are received Bit 7 Bit 6 Unit 0 0 mm 0 1 inch 1 0 mm and inch (default) 1 1 Not used | For the best performance, do not change the factory settings. The setting determined by these bits is informed to the transmitting terminal in the pre-message protocol exchange (in the DIS/NSF frames). |

Communication Switch 15 - Not used (do not change the settings)

| Communication Switch 16 | | |
|-------------------------|---|---|
| No | FUNCTION | COMMENTS |
| 0-1 | Not used | Do not change the settings. |
| 2 | Optional ISDN unit 0: Not installed 1: Installed | Change this bit to 1 when installing the optional ISDN unit. G4: Europe model only |
| 3-5 | Not used | Do not change the settings. |
| 6 | G4 Dual communication 0: Enabled 1: Disabled G4: Europe model only | 1: The machine uses only one B channel for communication. This enables a customer to occupy another B channel for other purposes such as internet communication. |
| 7 | Not used | Do not change the settings. |

| Communication Switch 17 | | |
|--------------------------------|--|---|
| No | FUNCTION | COMMENTS |
| 0 | SEP reception 0: Disabled 1: Enabled | 0: Polling transmission to another maker's machine using the SEP (Selective Polling) signal is disabled. |
| 1 | SUB reception 0: Disabled 1: Enabled | 0: Confidential reception to another maker's machine using the SUB (Sub-address) signal is disabled. |
| 2-7 | Not used | Do not change the settings. |

| |
|--|
| Communication Switch 18 - Not used (do not change the settings) |
| Communication Switch 19 - Not used (do not change the settings) |
| Communication Switch 1A - Not used (do not change the settings) |
| Communication Switch 1B - Not used (do not change the settings) |
| Communication Switch 1C - Not used (do not change the settings) |
| Communication Switch 1D - Not used (do not change the settings) |

| Communication Switch 1E | | |
|--------------------------------|---|--|
| No | FUNCTION | COMMENTS |
| 0 | Extension access code (0 to 7) to turn V.8 protocol On/Off 0: On 1: Off | If the PABX does not support V.8/V.34 protocol procedure, set this bit to "1" to disable V.8. Example: If "0" is the PSTN access code, set bit 0 to 1. When the machine detects "0" as the first dialed number, it automatically disables V.8 protocol. (Alternatively, if "3" is the PSTN access code, set bit 0 to 1.) |
| 1 | | |
| 2 | | |
| 3 | | |
| 4 | | |
| 5 | | |
| 6 | | |
| 7 | | |

| Communication Switch 1F | | |
|--------------------------------|--|---|
| No | FUNCTION | COMMENTS |
| 0 | Extension access code (8 and 9) to turn V.8 protocol On/Off 0: On 1: Off | Refer to communication switch 1E. Example: If "8" is the PSTN access code, set bit 0 to 1. When the machine detects "8" as the first dialed number, it automatically disables V.8 protocol. |
| 1 | | |
| 2-7 | Not used | Do not change the settings. |

4.2.5 G3 SWITCHES

| G3 Switch 00 | | | | | | | | | | | | | | | | | |
|--------------|---|---|----------------|--------------|----------------|---|---|----------|---|---|---------------|---|---|--------------|---|---|----------|
| No | FUNCTION | COMMENTS | | | | | | | | | | | | | | | |
| 0 | Monitor speaker during communication (tx and rx) | (0, 0): The monitor speaker is disabled all through the communication. (0, 1): The monitor speaker is on up to phase B in the T.30 protocol. (1, 0): Used for testing. The monitor speaker is on all through the communication. Make sure that you reset these bits after testing. | | | | | | | | | | | | | | | |
| 1 | <table border="0"> <tr> <td>Bit 1</td> <td>Bit 0</td> <td>Setting</td> </tr> <tr> <td>0</td> <td>0</td> <td>Disabled</td> </tr> <tr> <td>0</td> <td>1</td> <td>Up to Phase B</td> </tr> <tr> <td>1</td> <td>0</td> <td>All the time</td> </tr> <tr> <td>1</td> <td>1</td> <td>Not used</td> </tr> </table> | | Bit 1 | Bit 0 | Setting | 0 | 0 | Disabled | 0 | 1 | Up to Phase B | 1 | 0 | All the time | 1 | 1 | Not used |
| Bit 1 | Bit 0 | | Setting | | | | | | | | | | | | | | |
| 0 | 0 | | Disabled | | | | | | | | | | | | | | |
| 0 | 1 | | Up to Phase B | | | | | | | | | | | | | | |
| 1 | 0 | All the time | | | | | | | | | | | | | | | |
| 1 | 1 | Not used | | | | | | | | | | | | | | | |
| 2 | Monitor speaker during memory transmission 0: Disabled 1: Enabled | 1: The monitor speaker is enabled during memory transmission. | | | | | | | | | | | | | | | |
| 3-6 | Not used | Do not change the settings. | | | | | | | | | | | | | | | |
| 7 | Back to back test 0: Disabled 1: Enabled | Set this bit to 1 when you wish to do a back to back test. 115 V model: Be sure to connect jumpers JP5 and JP6 on the NCU before doing the test. 220 V model: Be sure to apply dc voltage between wires L1 and L2 on the NCU. | | | | | | | | | | | | | | | |

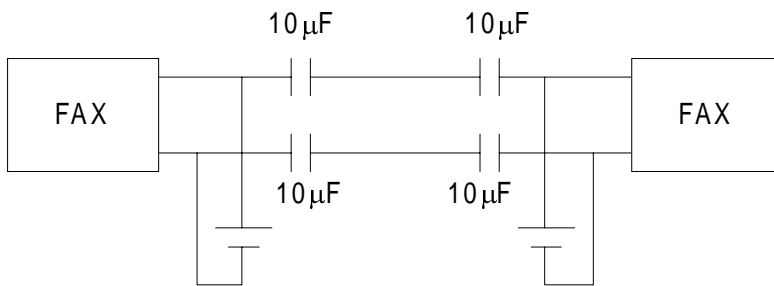

A891M603.WMF

Back-to-Back Connection:

The dc power supplies should be adjusted so that the line current to the NCU is about 30mA.

| G3 Switch 01 | | |
|--------------|---|--|
| No | FUNCTION | COMMENTS |
| 0-3 | Not used | Do not change the settings. |
| 4 | DIS frame length 0: 10 bytes 1: 4 bytes | 1: The bytes in the DIS frame after the 4th byte will not be transmitted (set to 1 if there are communication problems with PC-based faxes which cannot receive the extended DIS frames). |
| 5 | Not used | Do not change the setting. |
| 6 | CED/ANSam transmission 0: Disabled 1: Enabled | Do not change this setting, unless the communication problem is caused by the CED/ANSam transmission. |
| 7 | Not used | Do not change the setting. |

| G3 Switch 02 | | |
|---------------------|---|--|
| No | FUNCTION | COMMENTS |
| 0 | G3 protocol mode used 0: Standard and non-standard 1: Standard only | Change this bit to 1 only when the other end can only communicate with machines that send T.30-standard frames only. 1: Disables NSF/NSS signals (these are used in non-standard mode communication) |
| 1-4 | Not used | Do not change the settings. |
| 5 | Use of modem rate history for transmission using Quick/Speed Dials 0: Disabled 1: Enabled | 0: Communications using Quick/Speed Dials always start from the highest modem rate. 1: The machine refers to the modem rate history for communications with the same machine when determining the most suitable rate for the current communication. |
| 6 | AI short protocol (transmission and reception) 0: Disabled 1: Enabled | Refer to Appendix B in the Group 3 Facsimile Manual for details about AI Short Protocol. |
| 7 | Short preamble 0: Disabled 1: Enabled | Refer to Appendix B in the Group 3 Facsimile Manual for details about Short Preamble. |

| G3 Switch 03 | | |
|---------------------|---|---|
| No | FUNCTION | COMMENTS |
| 0 | DIS detection number (Echo countermeasure) 0: 1 1: 2 | 0: The machine will hang up if it receives the same DIS frame twice. 1: Before sending DCS, the machine will wait for the second DIS which is caused by echo on the line. |
| 1 | V.8 protocol in manual reception 0: Disabled 1: Enabled | 0: The machine sends CED instead of ANSam when starting a manual reception. 1: The machine sends ANSam during manual reception. |
| 2 | V.8 protocol 0: Disabled 1: Enabled | 0: V.8/V.34 communications will not be possible. Note: Do not set to 0 unless the line condition is always bad enough to slow down the data rate to 14.4 kbps or lower. |
| 3 | ECM frame size 0: 256 bytes 1: 64 bytes | Keep this bit at "0" in most cases. |

| G3 Switch 03 | | |
|---------------------|--|--|
| No | FUNCTION | COMMENTS |
| 4 | CTC transmission conditions 0: After one PPR signal received 1: After four PPR signals received (ITU-T standard) | 0: When using ECM in non-standard (NSF/NSS) mode, the machine sends a CTC to drop back the modem rate after receiving a PPR, if the following condition is met in communications at 14.4, 12.0, 9.6, and 7.2 kbps. $\sqrt{N \text{ Transmit}} \leq N \text{ Resend}$ N _{Transmit} - Number of transmitted frames N _{Resend} - Number of frames to be retransmitted 1: When using ECM, the machine sends a CTC to drop back the modem rate after receiving four PPRs. PPR, CTC: These are ECM protocol signals. This bit is not effective in V.34 communications. |
| 5 | Modem rate used for the next page after receiving a negative code (RTN or PIN) 0: No change 1: Fallback | 1: The machine's tx modem rate will fall back before sending the next page if a negative code is received. This bit is ignored if ECM is being used. |
| 6 | V.8 protocol in manual transmission 0: Disabled 1: Enabled | 1: The machine detects either ANSam or CED during manual transmission. |
| 7 | Not used | Do not change the settings. |

| G3 Switch 04 | | |
|---------------------|------------------------------------|--|
| No | FUNCTION | COMMENTS |
| 0 to 3 | Training error detection threshold | 0 - F (Hex); 0 - 15 bits If the number of error bits in the received TCF is below this threshold, the machine informs the sender that training has succeeded. |
| 4-7 | Not used | Do not change the settings. |

| G3 Switch 05 | | | | | | | | | | | | | | | | | | | | | | | | | | | | | | | | | | | | | | | | | | | | | | | | | | | | | | | | | | | | | | | | | | | | | | | | | | | | | |
|---------------------|--|-----------------------------|-------|---------------|---|---------------|------|---|---|------|-------|---|----------|---|---|----------|---|---|---|---|-------|---|---|---|---|-------|---|---|---|---|--------|---|---|---|---|--------|---|---|---|---|--------|---|---|---|---|--------|---|---|---|---|--------|---|---|---|---|--------|---|---|---|---|--------|---|---|---|---|--------|---|---|---|---|--------|---|---|---|---|--------|--|
| No | FUNCTION | COMMENTS | | | | | | | | | | | | | | | | | | | | | | | | | | | | | | | | | | | | | | | | | | | | | | | | | | | | | | | | | | | | | | | | | | | | | | | | | | | |
| 0 to 3 | Initial Tx modem rate <table border="1"> <thead> <tr> <th>Bit 3</th> <th>2</th> <th>1</th> <th>0</th> <th>Setting (bps)</th> </tr> </thead> <tbody> <tr><td>0</td><td>0</td><td>0</td><td>1</td><td>2.4 k</td></tr> <tr><td>0</td><td>0</td><td>1</td><td>0</td><td>4.8 k</td></tr> <tr><td>0</td><td>0</td><td>1</td><td>1</td><td>7.2 k</td></tr> <tr><td>0</td><td>1</td><td>0</td><td>0</td><td>9.6 k</td></tr> <tr><td>0</td><td>1</td><td>0</td><td>1</td><td>12.0 k</td></tr> <tr><td>0</td><td>1</td><td>1</td><td>0</td><td>14.4 k</td></tr> <tr><td>0</td><td>1</td><td>1</td><td>1</td><td>16.8 k</td></tr> <tr><td>1</td><td>0</td><td>0</td><td>0</td><td>19.2 k</td></tr> <tr><td>1</td><td>0</td><td>0</td><td>1</td><td>21.6 k</td></tr> <tr><td>1</td><td>0</td><td>1</td><td>0</td><td>24.0 k</td></tr> <tr><td>1</td><td>0</td><td>1</td><td>1</td><td>26.4 k</td></tr> <tr><td>1</td><td>1</td><td>0</td><td>0</td><td>28.8 k</td></tr> <tr><td>1</td><td>1</td><td>0</td><td>1</td><td>31.2 k</td></tr> <tr><td>1</td><td>1</td><td>1</td><td>0</td><td>33.6 k</td></tr> </tbody> </table> Other settings - Not used | Bit 3 | 2 | 1 | 0 | Setting (bps) | 0 | 0 | 0 | 1 | 2.4 k | 0 | 0 | 1 | 0 | 4.8 k | 0 | 0 | 1 | 1 | 7.2 k | 0 | 1 | 0 | 0 | 9.6 k | 0 | 1 | 0 | 1 | 12.0 k | 0 | 1 | 1 | 0 | 14.4 k | 0 | 1 | 1 | 1 | 16.8 k | 1 | 0 | 0 | 0 | 19.2 k | 1 | 0 | 0 | 1 | 21.6 k | 1 | 0 | 1 | 0 | 24.0 k | 1 | 0 | 1 | 1 | 26.4 k | 1 | 1 | 0 | 0 | 28.8 k | 1 | 1 | 0 | 1 | 31.2 k | 1 | 1 | 1 | 0 | 33.6 k | These bits set the initial starting modem rate for transmission. Use the dedicated transmission parameters if you need to change this for specific receivers. If a modem rate 14.4 kbps or slower is selected, V.8 protocol should be disabled manually. Cross reference V.8 protocol on/off - G3 switch 03, bit2 |
| Bit 3 | 2 | 1 | 0 | Setting (bps) | | | | | | | | | | | | | | | | | | | | | | | | | | | | | | | | | | | | | | | | | | | | | | | | | | | | | | | | | | | | | | | | | | | | | | | | | |
| 0 | 0 | 0 | 1 | 2.4 k | | | | | | | | | | | | | | | | | | | | | | | | | | | | | | | | | | | | | | | | | | | | | | | | | | | | | | | | | | | | | | | | | | | | | | | | | |
| 0 | 0 | 1 | 0 | 4.8 k | | | | | | | | | | | | | | | | | | | | | | | | | | | | | | | | | | | | | | | | | | | | | | | | | | | | | | | | | | | | | | | | | | | | | | | | | |
| 0 | 0 | 1 | 1 | 7.2 k | | | | | | | | | | | | | | | | | | | | | | | | | | | | | | | | | | | | | | | | | | | | | | | | | | | | | | | | | | | | | | | | | | | | | | | | | |
| 0 | 1 | 0 | 0 | 9.6 k | | | | | | | | | | | | | | | | | | | | | | | | | | | | | | | | | | | | | | | | | | | | | | | | | | | | | | | | | | | | | | | | | | | | | | | | | |
| 0 | 1 | 0 | 1 | 12.0 k | | | | | | | | | | | | | | | | | | | | | | | | | | | | | | | | | | | | | | | | | | | | | | | | | | | | | | | | | | | | | | | | | | | | | | | | | |
| 0 | 1 | 1 | 0 | 14.4 k | | | | | | | | | | | | | | | | | | | | | | | | | | | | | | | | | | | | | | | | | | | | | | | | | | | | | | | | | | | | | | | | | | | | | | | | | |
| 0 | 1 | 1 | 1 | 16.8 k | | | | | | | | | | | | | | | | | | | | | | | | | | | | | | | | | | | | | | | | | | | | | | | | | | | | | | | | | | | | | | | | | | | | | | | | | |
| 1 | 0 | 0 | 0 | 19.2 k | | | | | | | | | | | | | | | | | | | | | | | | | | | | | | | | | | | | | | | | | | | | | | | | | | | | | | | | | | | | | | | | | | | | | | | | | |
| 1 | 0 | 0 | 1 | 21.6 k | | | | | | | | | | | | | | | | | | | | | | | | | | | | | | | | | | | | | | | | | | | | | | | | | | | | | | | | | | | | | | | | | | | | | | | | | |
| 1 | 0 | 1 | 0 | 24.0 k | | | | | | | | | | | | | | | | | | | | | | | | | | | | | | | | | | | | | | | | | | | | | | | | | | | | | | | | | | | | | | | | | | | | | | | | | |
| 1 | 0 | 1 | 1 | 26.4 k | | | | | | | | | | | | | | | | | | | | | | | | | | | | | | | | | | | | | | | | | | | | | | | | | | | | | | | | | | | | | | | | | | | | | | | | | |
| 1 | 1 | 0 | 0 | 28.8 k | | | | | | | | | | | | | | | | | | | | | | | | | | | | | | | | | | | | | | | | | | | | | | | | | | | | | | | | | | | | | | | | | | | | | | | | | |
| 1 | 1 | 0 | 1 | 31.2 k | | | | | | | | | | | | | | | | | | | | | | | | | | | | | | | | | | | | | | | | | | | | | | | | | | | | | | | | | | | | | | | | | | | | | | | | | |
| 1 | 1 | 1 | 0 | 33.6 k | | | | | | | | | | | | | | | | | | | | | | | | | | | | | | | | | | | | | | | | | | | | | | | | | | | | | | | | | | | | | | | | | | | | | | | | | |
| 4 to 5 | Initial modem type for 9.6 k or 7.2 kbps. <table border="1"> <thead> <tr> <th>Bit 5</th> <th>Bit 4</th> <th>Setting</th> </tr> </thead> <tbody> <tr><td>0</td><td>0</td><td>V.29</td></tr> <tr><td>0</td><td>1</td><td>V.17</td></tr> <tr><td>1</td><td>0</td><td>Not used</td></tr> <tr><td>1</td><td>1</td><td>Not used</td></tr> </tbody> </table> | Bit 5 | Bit 4 | Setting | 0 | 0 | V.29 | 0 | 1 | V.17 | 1 | 0 | Not used | 1 | 1 | Not used | These bits set the initial modem type for 9.6 and 7.2 kbps, if the initial modem rate is set at these speeds. | | | | | | | | | | | | | | | | | | | | | | | | | | | | | | | | | | | | | | | | | | | | | | | | | | | | | | | | | | | | |
| Bit 5 | Bit 4 | Setting | | | | | | | | | | | | | | | | | | | | | | | | | | | | | | | | | | | | | | | | | | | | | | | | | | | | | | | | | | | | | | | | | | | | | | | | | | | |
| 0 | 0 | V.29 | | | | | | | | | | | | | | | | | | | | | | | | | | | | | | | | | | | | | | | | | | | | | | | | | | | | | | | | | | | | | | | | | | | | | | | | | | | |
| 0 | 1 | V.17 | | | | | | | | | | | | | | | | | | | | | | | | | | | | | | | | | | | | | | | | | | | | | | | | | | | | | | | | | | | | | | | | | | | | | | | | | | | |
| 1 | 0 | Not used | | | | | | | | | | | | | | | | | | | | | | | | | | | | | | | | | | | | | | | | | | | | | | | | | | | | | | | | | | | | | | | | | | | | | | | | | | | |
| 1 | 1 | Not used | | | | | | | | | | | | | | | | | | | | | | | | | | | | | | | | | | | | | | | | | | | | | | | | | | | | | | | | | | | | | | | | | | | | | | | | | | | |
| 6-7 | Not used | Do not change the settings. | | | | | | | | | | | | | | | | | | | | | | | | | | | | | | | | | | | | | | | | | | | | | | | | | | | | | | | | | | | | | | | | | | | | | | | | | | | |

| G3 Switch 06 | | | | | | | | | | | | | | | | | | | | | | | | | | | | | | | | | | | | | | | | | | | | | | | | | | | | | | | | | | | | | | | | | | | | | | | | | | | | | |
|---------------------|--|-----------------|---|---------------|---|---------------|---|---|---|---|-------|---|---|---|---|-------|---|---|---|---|-------|---|---|---|---|-------|---|---|---|---|--------|---|---|---|---|--------|---|---|---|---|--------|---|---|---|---|--------|---|---|---|---|--------|---|---|---|---|--------|---|---|---|---|--------|---|---|---|---|--------|---|---|---|---|--------|---|---|---|---|--------|---|
| No | FUNCTION | COMMENTS | | | | | | | | | | | | | | | | | | | | | | | | | | | | | | | | | | | | | | | | | | | | | | | | | | | | | | | | | | | | | | | | | | | | | | | | | | | |
| 0 to 3 | Initial Rx modem rate <table border="1"> <thead> <tr> <th>Bit 3</th> <th>2</th> <th>1</th> <th>0</th> <th>Setting (bps)</th> </tr> </thead> <tbody> <tr><td>0</td><td>0</td><td>0</td><td>1</td><td>2.4 k</td></tr> <tr><td>0</td><td>0</td><td>1</td><td>0</td><td>4.8 k</td></tr> <tr><td>0</td><td>0</td><td>1</td><td>1</td><td>7.2 k</td></tr> <tr><td>0</td><td>1</td><td>0</td><td>0</td><td>9.6 k</td></tr> <tr><td>0</td><td>1</td><td>0</td><td>1</td><td>12.0 k</td></tr> <tr><td>0</td><td>1</td><td>1</td><td>0</td><td>14.4 k</td></tr> <tr><td>0</td><td>1</td><td>1</td><td>1</td><td>16.8 k</td></tr> <tr><td>1</td><td>0</td><td>0</td><td>0</td><td>19.2 k</td></tr> <tr><td>1</td><td>0</td><td>0</td><td>1</td><td>21.6 k</td></tr> <tr><td>1</td><td>0</td><td>1</td><td>0</td><td>24.0 k</td></tr> <tr><td>1</td><td>0</td><td>1</td><td>1</td><td>26.4 k</td></tr> <tr><td>1</td><td>1</td><td>0</td><td>0</td><td>28.8 k</td></tr> <tr><td>1</td><td>1</td><td>0</td><td>1</td><td>31.2 k</td></tr> <tr><td>1</td><td>1</td><td>1</td><td>0</td><td>33.6 k</td></tr> </tbody> </table> Other settings - Not used | Bit 3 | 2 | 1 | 0 | Setting (bps) | 0 | 0 | 0 | 1 | 2.4 k | 0 | 0 | 1 | 0 | 4.8 k | 0 | 0 | 1 | 1 | 7.2 k | 0 | 1 | 0 | 0 | 9.6 k | 0 | 1 | 0 | 1 | 12.0 k | 0 | 1 | 1 | 0 | 14.4 k | 0 | 1 | 1 | 1 | 16.8 k | 1 | 0 | 0 | 0 | 19.2 k | 1 | 0 | 0 | 1 | 21.6 k | 1 | 0 | 1 | 0 | 24.0 k | 1 | 0 | 1 | 1 | 26.4 k | 1 | 1 | 0 | 0 | 28.8 k | 1 | 1 | 0 | 1 | 31.2 k | 1 | 1 | 1 | 0 | 33.6 k | These bits set the initial starting modem rate for reception. Use a lower setting if high speeds pose problems during reception. If a modem rate 14.4 kbps or slower is selected, V.8 protocol should be disabled manually. Cross reference V.8 protocol on/off - G3 switch 03, bit2 |
| Bit 3 | 2 | 1 | 0 | Setting (bps) | | | | | | | | | | | | | | | | | | | | | | | | | | | | | | | | | | | | | | | | | | | | | | | | | | | | | | | | | | | | | | | | | | | | | | | | | |
| 0 | 0 | 0 | 1 | 2.4 k | | | | | | | | | | | | | | | | | | | | | | | | | | | | | | | | | | | | | | | | | | | | | | | | | | | | | | | | | | | | | | | | | | | | | | | | | |
| 0 | 0 | 1 | 0 | 4.8 k | | | | | | | | | | | | | | | | | | | | | | | | | | | | | | | | | | | | | | | | | | | | | | | | | | | | | | | | | | | | | | | | | | | | | | | | | |
| 0 | 0 | 1 | 1 | 7.2 k | | | | | | | | | | | | | | | | | | | | | | | | | | | | | | | | | | | | | | | | | | | | | | | | | | | | | | | | | | | | | | | | | | | | | | | | | |
| 0 | 1 | 0 | 0 | 9.6 k | | | | | | | | | | | | | | | | | | | | | | | | | | | | | | | | | | | | | | | | | | | | | | | | | | | | | | | | | | | | | | | | | | | | | | | | | |
| 0 | 1 | 0 | 1 | 12.0 k | | | | | | | | | | | | | | | | | | | | | | | | | | | | | | | | | | | | | | | | | | | | | | | | | | | | | | | | | | | | | | | | | | | | | | | | | |
| 0 | 1 | 1 | 0 | 14.4 k | | | | | | | | | | | | | | | | | | | | | | | | | | | | | | | | | | | | | | | | | | | | | | | | | | | | | | | | | | | | | | | | | | | | | | | | | |
| 0 | 1 | 1 | 1 | 16.8 k | | | | | | | | | | | | | | | | | | | | | | | | | | | | | | | | | | | | | | | | | | | | | | | | | | | | | | | | | | | | | | | | | | | | | | | | | |
| 1 | 0 | 0 | 0 | 19.2 k | | | | | | | | | | | | | | | | | | | | | | | | | | | | | | | | | | | | | | | | | | | | | | | | | | | | | | | | | | | | | | | | | | | | | | | | | |
| 1 | 0 | 0 | 1 | 21.6 k | | | | | | | | | | | | | | | | | | | | | | | | | | | | | | | | | | | | | | | | | | | | | | | | | | | | | | | | | | | | | | | | | | | | | | | | | |
| 1 | 0 | 1 | 0 | 24.0 k | | | | | | | | | | | | | | | | | | | | | | | | | | | | | | | | | | | | | | | | | | | | | | | | | | | | | | | | | | | | | | | | | | | | | | | | | |
| 1 | 0 | 1 | 1 | 26.4 k | | | | | | | | | | | | | | | | | | | | | | | | | | | | | | | | | | | | | | | | | | | | | | | | | | | | | | | | | | | | | | | | | | | | | | | | | |
| 1 | 1 | 0 | 0 | 28.8 k | | | | | | | | | | | | | | | | | | | | | | | | | | | | | | | | | | | | | | | | | | | | | | | | | | | | | | | | | | | | | | | | | | | | | | | | | |
| 1 | 1 | 0 | 1 | 31.2 k | | | | | | | | | | | | | | | | | | | | | | | | | | | | | | | | | | | | | | | | | | | | | | | | | | | | | | | | | | | | | | | | | | | | | | | | | |
| 1 | 1 | 1 | 0 | 33.6 k | | | | | | | | | | | | | | | | | | | | | | | | | | | | | | | | | | | | | | | | | | | | | | | | | | | | | | | | | | | | | | | | | | | | | | | | | |

| | |
|--|--|
| <p>4 to 7</p> <p>Bit 7 6 5 4 Setting</p> <p>0 0 0 1 V.27ter</p> <p>0 0 1 0 V.27ter, V.29</p> <p>0 0 1 1 V.27ter, V.29 V.33</p> <p>0 1 0 0 V.27ter, V.29, V.17/V.33</p> <p>0 1 0 1 V.27ter, V.29, V.17/V33, V.34</p> <p>Other settings - Not used</p> | <p>The setting of these bits is used to inform the transmitting terminal of the available modem type for the machine in receive mode.</p> <p>If V.34 is not selected, V.8 protocol must be disabled manually.</p> <p>Cross reference V.8 protocol on/off - G3 switch 03, bit2</p> |
|--|--|

| G3 Switch 07 | | |
|---|---|---|
| No | FUNCTION | COMMENTS |
| <p>0 to 1</p> <p>Bit 1 Bit 0 Setting</p> <p>0 0 None</p> <p>0 1 Low</p> <p>1 0 Medium</p> <p>1 1 High</p> | <p>PSTN cable equalizer (tx mode: Internal)</p> | <p>Use a higher setting if there is signal loss at higher frequencies because of the length of wire between the modem and the telephone exchange.</p> <p>Use the dedicated transmission parameters for specific receivers.</p> <p>Also, try using the cable equalizer if one or more of the following symptoms occurs.</p> <ul style="list-style-type: none"> • Communication error • Modem rate fallback occurs frequently. <p>Note: This setting is not effective in V.34 communications.</p> |
| <p>2 to 3</p> <p>Bit 3 Bit 2 Setting</p> <p>0 0 None</p> <p>0 1 Low</p> <p>1 0 Medium</p> <p>1 1 High</p> | <p>PSTN cable equalizer (rx mode: Internal)</p> | <p>Use a higher setting if there is signal loss at higher frequencies because of the length of wire between the modem and the telephone exchange.</p> <p>Also, try using the cable equalizer if one or more of the following symptoms occurs.</p> <ul style="list-style-type: none"> • Communication error with error codes such as 0-20, 0-23, etc. • Modem rate fallback occurs frequently. <p>Note: This setting is not effective in V.34 communications.</p> |
| <p>4</p> | <p>PSTN cable equalizer (V.8/V.17 rx mode: External)</p> <p>0: Disabled</p> <p>1: Enabled</p> | <p>Keep this bit at "1".</p> |
| <p>5</p> | <p>PSTN cable equalizer (V.34 rx mode; External)</p> | <p>Keep this bit at "1".</p> |
| <p>6-7</p> | <p>Not used</p> | <p>Do not change the settings.</p> |

| G3 Switch 08 | | | | |
|---------------------|--|--------------|----------------|---|
| | FUNCTION | | | COMMENTS |
| 0 | PABX cable equalizer (tx mode) | | | Use a higher setting if there is signal loss at higher frequencies because of the length of wire between the modem and the telephone exchange. Use the dedicated transmission parameters if you need to change this for specific receivers. Also, try using the cable equalizer if one or more of the following symptoms occurs: <ul style="list-style-type: none"> • Communication error • Modem rate fallback occurs frequently. Note: This setting is ineffective in V.34 communications. |
| 1 | Bit 1 | Bit 0 | Setting | |
| | 0 | 0 | None | |
| | 0 | 1 | Low | |
| | 1 | 1 | High | |
| 2 | PABX cable equalizer (rx mode) | | | Use a higher setting if there is signal loss at higher frequencies because of the length of wire between the modem and the telephone exchange. Also, try using the cable equalizer if one or more of the following symptoms occurs: <ul style="list-style-type: none"> • Communication error with error codes such as 0-20, 0-23, etc. • Modem rate fallback occurs frequently. Note: This setting is ineffective in V.34 communications. |
| 3 | Bit 3 | Bit 2 | Setting | |
| | 0 | 0 | None | |
| | 0 | 1 | Low | |
| | 1 | 1 | High | |
| 4 | PABX external cable equalizer (V.17, V.8 rx mode) 0: Disabled 1: Enabled | | | Set this bit to 0 when line quality is good. (e.g. for a digital PABX) |
| 5 | PABX external cable equalizer (V.34 rx mode) 0: Disabled 1: Enabled | | | Set this bit to 0 when line quality is good. (e.g. for a digital PABX) The V.34 modem rate may decrease if the equalizer is over-corrected. |
| 6-7 | Not used | | | Do not change these settings. |

| G3 Switch 09 | | | | | | | | | | | | | | | | | |
|---------------------|--|---|--------------|----------------|---|---|------|---|---|-----|---|---|--------|---|---|------|--|
| No | FUNCTION | COMMENTS | | | | | | | | | | | | | | | |
| 0 to 1 | ISDN cable equalizer (tx mode: Internal) <table border="1"> <thead> <tr> <th>Bit 1</th> <th>Bit 0</th> <th>Setting</th> </tr> </thead> <tbody> <tr> <td>0</td> <td>0</td> <td>None</td> </tr> <tr> <td>0</td> <td>1</td> <td>Low</td> </tr> <tr> <td>1</td> <td>0</td> <td>Medium</td> </tr> <tr> <td>1</td> <td>1</td> <td>High</td> </tr> </tbody> </table> ISDN: Europe models only | Bit 1 | Bit 0 | Setting | 0 | 0 | None | 0 | 1 | Low | 1 | 0 | Medium | 1 | 1 | High | Use a higher setting if there is signal loss at higher frequencies because of the length of wire between the modem and the telephone exchange. Use the dedicated transmission parameters for specific receivers. Also, try using the cable equalizer if one or more of the following symptoms occurs. <ul style="list-style-type: none"> • Communication error • Modem rate fallback occurs frequently. Note: This setting is not effective in V.34 communications. |
| Bit 1 | Bit 0 | Setting | | | | | | | | | | | | | | | |
| 0 | 0 | None | | | | | | | | | | | | | | | |
| 0 | 1 | Low | | | | | | | | | | | | | | | |
| 1 | 0 | Medium | | | | | | | | | | | | | | | |
| 1 | 1 | High | | | | | | | | | | | | | | | |
| 2 to 3 | ISDN cable equalizer (rx mode: Internal) <table border="1"> <thead> <tr> <th>Bit 3</th> <th>Bit 2</th> <th>Setting</th> </tr> </thead> <tbody> <tr> <td>0</td> <td>0</td> <td>None</td> </tr> <tr> <td>0</td> <td>1</td> <td>Low</td> </tr> <tr> <td>1</td> <td>0</td> <td>Medium</td> </tr> <tr> <td>1</td> <td>1</td> <td>High</td> </tr> </tbody> </table> ISDN: Europe models only | Bit 3 | Bit 2 | Setting | 0 | 0 | None | 0 | 1 | Low | 1 | 0 | Medium | 1 | 1 | High | Use a higher setting if there is signal loss at higher frequencies because of the length of wire between the modem and the telephone exchange. Also, try using the cable equalizer if one or more of the following symptoms occurs. <ul style="list-style-type: none"> • Communication error with error codes such as 0-20, 0-23, etc. • Modem rate fallback occurs frequently. Note: This setting is not effective in V.34 communications. |
| Bit 3 | Bit 2 | Setting | | | | | | | | | | | | | | | |
| 0 | 0 | None | | | | | | | | | | | | | | | |
| 0 | 1 | Low | | | | | | | | | | | | | | | |
| 1 | 0 | Medium | | | | | | | | | | | | | | | |
| 1 | 1 | High | | | | | | | | | | | | | | | |
| 4 | ISDN cable equalizer (V.8/V.17 rx mode: External) 0: Disabled 1: Enabled | Keep this bit at "0" in most cases. ISDN: Europe models only | | | | | | | | | | | | | | | |
| 5 | ISDN cable equalizer (V.34 rx mode: External) 0: Disabled 1: Enabled | Keep this bit at "0" in most cases. ISDN: Europe models only | | | | | | | | | | | | | | | |
| 6-7 | Not used | Do not change the settings. | | | | | | | | | | | | | | | |

| G3 Switch 0A | | | | |
|---------------------|--|--------------|-------------------|--|
| No | FUNCTION | | | COMMENTS |
| 0 | Maximum allowable carrier drop during image data reception | | | These bits set the acceptable modem carrier drop time. Try using a longer setting if error code 0-22 is frequent. |
| 1 | Bit 1 | Bit 0 | Value (ms) | |
| | 0 | 0 | 200 | |
| | 0 | 1 | 400 | |
| | 1 | 1 | Not used | |
| 2-3 | Not used | | | Do not change the settings. |
| 4 | Maximum allowable frame interval during image data reception. 0: 5 s 1: 13 s | | | This bit set the maximum interval between EOL (end-of-line) signals and the maximum interval between ECM frames from the other end. Try using a longer setting if error code 0-21 is frequent. |
| 5 | Not used | | | Do not change the settings. |
| 6 | Reconstruction time for the first line in receive mode 0: 6 s 1: 12 s | | | When the sending terminal is controlled by a computer, there may be a delay in receiving page data after the local machine accepts set-up data and sends CFR. This is outside the T.30 recommendation. But, if this delay occurs, set this bit to 1 to give the sending machine more time to send data. Refer to error code 0-20. ITU-T T.30 recommendation: The first line should come within 5 s of CFR. |
| 7 | Not used | | | Do not change the settings. |

| G3 Switch 0B | | | | |
|---------------------|---|--|--|---|
| No | FUNCTION | | | COMMENTS |
| 0 | Protocol requirements: Europe 0: Disabled 1: Enabled | | | The machine does not automatically reset these bits for each country after a country code (System Switch 0F) is programmed. Change the required bits manually at installation. |
| 1 | Protocol requirements: Spain 0: Disabled 1: Enabled | | | |
| 2 | Protocol requirements: Germany 0: Disabled 1: Enabled | | | |
| 3 | Protocol requirements: France 0: Disabled 1: Enabled | | | |
| 4 | PTT requirements: Germany 0: Disabled 1: Enabled | | | |
| 5 | PTT requirements: France 0: Disabled 1: Enabled | | | |
| 6 | Not used | | | Do not change the settings. |
| 7 | DTS requirements : Germany 0: Disabled 1: Enabled | | | Change this bit manually if required. |

| G3 Switch 0C | | | | |
|---------------------|----------------------|--------------|-----------------|---|
| No | FUNCTION | | | COMMENTS |
| 0 | Pulse dialing method | | | P = Number of pulses sent out, N = Number dialed. |
| 1 | Bit 1 | Bit 0 | Setting | |
| | 0 | 0 | Normal (P=N) | |
| | 0 | 1 | Oslo (P=10 - N) | |
| | 1 | 0 | Sweden (N+1) | |
| | 1 | 1 | Not used | |
| 2-7 | Not used | | | Do not change the settings. |

| G3 Switch 0D | | | | |
|---------------------|---|----------|----------------------|---|
| No | FUNCTION | | | COMMENTS |
| 0-1 | Not used | | | Do not change the settings. |
| 2 to 5 | Data rate threshold during V.34 reception | | | The machine changes the modulation parameters in the MPh signal to lower the initial modem rate during V.34 reception. If this switch is set to "0111", the machine lowers the initial speed one step, for example, from 28,800 to 26,400 bps. This switch reduces transmission time if the machine frequently sends PPR signals during V.34 reception. |
| | Bit 5 | 4 | 3 2 Setting | |
| | 0 | 0 0 | 0 Normal | |
| | | : | | |
| | 0 | 1 1 | 1 Lower by one step | |
| | | : | | |
| | 1 | 1 1 | 1 Lower by two steps | |
| 6 | Not used | | | Do not change the settings. |
| 7 | B signal detection time for V.34 polling transmission 0: 75 ms (default setting) 1: 65 ms | | | Change this switch only when there are communication errors during V.34 polling transmission to a machine with a Panasonic modem. |

G3 Switch 0E - Not used (do not change the settings)

| G3 Switch 0F | | | | |
|---------------------|---|--|--|--|
| No | FUNCTION | | | COMMENTS |
| 0 | Alarm when an error occurred in Phase C or later 0: Disabled 1: Enabled | | | If the customer wants to hear an alarm after each error communication, change this bit to "1". |
| 1 | Alarm when the handset is off-hook at the end of communication 0: Disabled 1: Enabled | | | If the customer wants to hear an alarm if the handset is off-hook at the end of fax communication, change this bit to "1". |
| 2-7 | Not used | | | Do not change the settings. |

4.3 NCU PARAMETERS



The following tables give the RAM addresses and the parameter calculation units that the machine uses for ringing signal detection and automatic dialing. The factory settings for each country are also given. Most of these must be changed by RAM read/write (Function 06-1), but some can be changed using NCU Parameter programming (Function 06-2); if Function 06-2 can be used, this will be indicated in the Remarks column. The RAM is programmed in hex code unless (BCD) is included in the Unit column.

| Address | Function | Unit | Remarks | | | | | | | | | | | | | | | | | | | | | | | | | | | | | | | | | | | | | | | | | | | | | | | | | | | | | | | | | | | | | | | | | | | | | | | | | | | | | | | | | | | | |
|--------------|--|--|--|---------|-----|--------|----|----|---------|----|----|----|----|----|-------|----|----|---------|----|----|---------|----|----|---------|----|----|---------|----|----|---------|----|----|--------|----|----|--------|----|----|-------------|----|----|----------|----|----|---------|----|----|-------|----|----|--------|----|----|-----|----|----|------|----|----|-----------|----|----|--------------|----|----|-----------|----|----|-------------|----|----|-----------|----|----|----------|----|----|-------|----|----|--------|----|----|--------|----|----|--|
| 680400 | Country code for NCU parameters  | Use the Hex value to program the country code directly into this address, or use the decimal value to program it using Function 06-2 (parameter 00). | | | | | | | | | | | | | | | | | | | | | | | | | | | | | | | | | | | | | | | | | | | | | | | | | | | | | | | | | | | | | | | | | | | | | | | | | | | | | | | | | | | | | |
| | | <table border="1"> <thead> <tr> <th>Country</th> <th>Decimal</th> <th>Hex</th> </tr> </thead> <tbody> <tr><td>France</td><td>00</td><td>00</td></tr> <tr><td>Germany</td><td>01</td><td>01</td></tr> <tr><td>UK</td><td>02</td><td>02</td></tr> <tr><td>Italy</td><td>03</td><td>03</td></tr> <tr><td>Austria</td><td>04</td><td>04</td></tr> <tr><td>Belgium</td><td>05</td><td>05</td></tr> <tr><td>Denmark</td><td>06</td><td>06</td></tr> <tr><td>Finland</td><td>07</td><td>07</td></tr> <tr><td>Ireland</td><td>08</td><td>08</td></tr> <tr><td>Norway</td><td>09</td><td>09</td></tr> <tr><td>Sweden</td><td>10</td><td>0A</td></tr> <tr><td>Switzerland</td><td>11</td><td>0B</td></tr> <tr><td>Portugal</td><td>12</td><td>0C</td></tr> <tr><td>Holland</td><td>13</td><td>0D</td></tr> <tr><td>Spain</td><td>14</td><td>0E</td></tr> <tr><td>Israel</td><td>15</td><td>0F</td></tr> <tr><td>USA</td><td>17</td><td>11</td></tr> <tr><td>Asia</td><td>18</td><td>12</td></tr> <tr><td>Hong Kong</td><td>20</td><td>14</td></tr> <tr><td>South Africa</td><td>21</td><td>15</td></tr> <tr><td>Australia</td><td>22</td><td>16</td></tr> <tr><td>New Zealand</td><td>23</td><td>17</td></tr> <tr><td>Singapore</td><td>24</td><td>18</td></tr> <tr><td>Malaysia</td><td>25</td><td>19</td></tr> <tr><td>China</td><td>26</td><td>1A</td></tr> <tr><td>Taiwan</td><td>27</td><td>1B</td></tr> <tr><td>Greece</td><td>33</td><td>21</td></tr> </tbody> </table> | Country | Decimal | Hex | France | 00 | 00 | Germany | 01 | 01 | UK | 02 | 02 | Italy | 03 | 03 | Austria | 04 | 04 | Belgium | 05 | 05 | Denmark | 06 | 06 | Finland | 07 | 07 | Ireland | 08 | 08 | Norway | 09 | 09 | Sweden | 10 | 0A | Switzerland | 11 | 0B | Portugal | 12 | 0C | Holland | 13 | 0D | Spain | 14 | 0E | Israel | 15 | 0F | USA | 17 | 11 | Asia | 18 | 12 | Hong Kong | 20 | 14 | South Africa | 21 | 15 | Australia | 22 | 16 | New Zealand | 23 | 17 | Singapore | 24 | 18 | Malaysia | 25 | 19 | China | 26 | 1A | Taiwan | 27 | 1B | Greece | 33 | 21 | |
| Country | Decimal | Hex | | | | | | | | | | | | | | | | | | | | | | | | | | | | | | | | | | | | | | | | | | | | | | | | | | | | | | | | | | | | | | | | | | | | | | | | | | | | | | | | | | | | | |
| France | 00 | 00 | | | | | | | | | | | | | | | | | | | | | | | | | | | | | | | | | | | | | | | | | | | | | | | | | | | | | | | | | | | | | | | | | | | | | | | | | | | | | | | | | | | | | |
| Germany | 01 | 01 | | | | | | | | | | | | | | | | | | | | | | | | | | | | | | | | | | | | | | | | | | | | | | | | | | | | | | | | | | | | | | | | | | | | | | | | | | | | | | | | | | | | | |
| UK | 02 | 02 | | | | | | | | | | | | | | | | | | | | | | | | | | | | | | | | | | | | | | | | | | | | | | | | | | | | | | | | | | | | | | | | | | | | | | | | | | | | | | | | | | | | | |
| Italy | 03 | 03 | | | | | | | | | | | | | | | | | | | | | | | | | | | | | | | | | | | | | | | | | | | | | | | | | | | | | | | | | | | | | | | | | | | | | | | | | | | | | | | | | | | | | |
| Austria | 04 | 04 | | | | | | | | | | | | | | | | | | | | | | | | | | | | | | | | | | | | | | | | | | | | | | | | | | | | | | | | | | | | | | | | | | | | | | | | | | | | | | | | | | | | | |
| Belgium | 05 | 05 | | | | | | | | | | | | | | | | | | | | | | | | | | | | | | | | | | | | | | | | | | | | | | | | | | | | | | | | | | | | | | | | | | | | | | | | | | | | | | | | | | | | | |
| Denmark | 06 | 06 | | | | | | | | | | | | | | | | | | | | | | | | | | | | | | | | | | | | | | | | | | | | | | | | | | | | | | | | | | | | | | | | | | | | | | | | | | | | | | | | | | | | | |
| Finland | 07 | 07 | | | | | | | | | | | | | | | | | | | | | | | | | | | | | | | | | | | | | | | | | | | | | | | | | | | | | | | | | | | | | | | | | | | | | | | | | | | | | | | | | | | | | |
| Ireland | 08 | 08 | | | | | | | | | | | | | | | | | | | | | | | | | | | | | | | | | | | | | | | | | | | | | | | | | | | | | | | | | | | | | | | | | | | | | | | | | | | | | | | | | | | | | |
| Norway | 09 | 09 | | | | | | | | | | | | | | | | | | | | | | | | | | | | | | | | | | | | | | | | | | | | | | | | | | | | | | | | | | | | | | | | | | | | | | | | | | | | | | | | | | | | | |
| Sweden | 10 | 0A | | | | | | | | | | | | | | | | | | | | | | | | | | | | | | | | | | | | | | | | | | | | | | | | | | | | | | | | | | | | | | | | | | | | | | | | | | | | | | | | | | | | | |
| Switzerland | 11 | 0B | | | | | | | | | | | | | | | | | | | | | | | | | | | | | | | | | | | | | | | | | | | | | | | | | | | | | | | | | | | | | | | | | | | | | | | | | | | | | | | | | | | | | |
| Portugal | 12 | 0C | | | | | | | | | | | | | | | | | | | | | | | | | | | | | | | | | | | | | | | | | | | | | | | | | | | | | | | | | | | | | | | | | | | | | | | | | | | | | | | | | | | | | |
| Holland | 13 | 0D | | | | | | | | | | | | | | | | | | | | | | | | | | | | | | | | | | | | | | | | | | | | | | | | | | | | | | | | | | | | | | | | | | | | | | | | | | | | | | | | | | | | | |
| Spain | 14 | 0E | | | | | | | | | | | | | | | | | | | | | | | | | | | | | | | | | | | | | | | | | | | | | | | | | | | | | | | | | | | | | | | | | | | | | | | | | | | | | | | | | | | | | |
| Israel | 15 | 0F | | | | | | | | | | | | | | | | | | | | | | | | | | | | | | | | | | | | | | | | | | | | | | | | | | | | | | | | | | | | | | | | | | | | | | | | | | | | | | | | | | | | | |
| USA | 17 | 11 | | | | | | | | | | | | | | | | | | | | | | | | | | | | | | | | | | | | | | | | | | | | | | | | | | | | | | | | | | | | | | | | | | | | | | | | | | | | | | | | | | | | | |
| Asia | 18 | 12 | | | | | | | | | | | | | | | | | | | | | | | | | | | | | | | | | | | | | | | | | | | | | | | | | | | | | | | | | | | | | | | | | | | | | | | | | | | | | | | | | | | | | |
| Hong Kong | 20 | 14 | | | | | | | | | | | | | | | | | | | | | | | | | | | | | | | | | | | | | | | | | | | | | | | | | | | | | | | | | | | | | | | | | | | | | | | | | | | | | | | | | | | | | |
| South Africa | 21 | 15 | | | | | | | | | | | | | | | | | | | | | | | | | | | | | | | | | | | | | | | | | | | | | | | | | | | | | | | | | | | | | | | | | | | | | | | | | | | | | | | | | | | | | |
| Australia | 22 | 16 | | | | | | | | | | | | | | | | | | | | | | | | | | | | | | | | | | | | | | | | | | | | | | | | | | | | | | | | | | | | | | | | | | | | | | | | | | | | | | | | | | | | | |
| New Zealand | 23 | 17 | | | | | | | | | | | | | | | | | | | | | | | | | | | | | | | | | | | | | | | | | | | | | | | | | | | | | | | | | | | | | | | | | | | | | | | | | | | | | | | | | | | | | |
| Singapore | 24 | 18 | | | | | | | | | | | | | | | | | | | | | | | | | | | | | | | | | | | | | | | | | | | | | | | | | | | | | | | | | | | | | | | | | | | | | | | | | | | | | | | | | | | | | |
| Malaysia | 25 | 19 | | | | | | | | | | | | | | | | | | | | | | | | | | | | | | | | | | | | | | | | | | | | | | | | | | | | | | | | | | | | | | | | | | | | | | | | | | | | | | | | | | | | | |
| China | 26 | 1A | | | | | | | | | | | | | | | | | | | | | | | | | | | | | | | | | | | | | | | | | | | | | | | | | | | | | | | | | | | | | | | | | | | | | | | | | | | | | | | | | | | | | |
| Taiwan | 27 | 1B | | | | | | | | | | | | | | | | | | | | | | | | | | | | | | | | | | | | | | | | | | | | | | | | | | | | | | | | | | | | | | | | | | | | | | | | | | | | | | | | | | | | | |
| Greece | 33 | 21 | | | | | | | | | | | | | | | | | | | | | | | | | | | | | | | | | | | | | | | | | | | | | | | | | | | | | | | | | | | | | | | | | | | | | | | | | | | | | | | | | | | | | |
| 680401 | Line current detection time | 20 ms | Line current detection is disabled. Line current is not detected if 680401 contains FF. | | | | | | | | | | | | | | | | | | | | | | | | | | | | | | | | | | | | | | | | | | | | | | | | | | | | | | | | | | | | | | | | | | | | | | | | | | | | | | | | | | | | |
| 680402 | Line current wait time | | | | | | | | | | | | | | | | | | | | | | | | | | | | | | | | | | | | | | | | | | | | | | | | | | | | | | | | | | | | | | | | | | | | | | | | | | | | | | | | | | | | | | |
| 680403 | Line current drop detect time | | | | | | | | | | | | | | | | | | | | | | | | | | | | | | | | | | | | | | | | | | | | | | | | | | | | | | | | | | | | | | | | | | | | | | | | | | | | | | | | | | | | | | |

| Address | Function | Unit | Remarks |
|---------|--|----------|--|
| 680404 | PSTN dial tone frequency upper limit (high byte) | Hz (BCD) | If both addresses contain FF(H), tone detection is disabled. |
| 680405 | PSTN dial tone frequency upper limit (low byte) | | |
| 680406 | PSTN dial tone frequency lower limit (high byte) | Hz (BCD) | If both addresses contain FF(H), tone detection is disabled. |
| 680407 | PSTN dial tone frequency lower limit (low byte) | | |
| 680408 | PSTN dial tone detection time | 20 ms | If 680408 contains FF(H), the machine pauses for the pause time (address 68040D / 68040E). Italy: See Note 2. |
| 680409 | PSTN dial tone reset time (LOW) | | |
| 68040A | PSTN dial tone reset time (HIGH) | | |
| 68040B | PSTN dial tone continuous tone time | | |
| 68040C | PSTN dial tone permissible drop time | | |
| 68040D | PSTN wait interval (LOW) | | |
| 68040E | PSTN wait interval (HIGH) | 20 ms | Detection is disabled if this contains FF. |
| 68040F | PSTN ring-back tone detection time | | |
| 680410 | PSTN ring-back tone off detection time | 20 ms | |
| 680411 | PSTN detection time for silent period after ring-back tone detected (LOW) | 20 ms | |
| 680412 | PSTN detection time for silent period after ring-back tone detected (HIGH) | 20 ms | |
| 680413 | PSTN busy tone frequency upper limit (high byte) | Hz (BCD) | If both addresses contain FF(H), tone detection is disabled. |
| 680414 | PSTN busy tone frequency upper limit (low byte) | | |
| 680415 | PSTN busy tone frequency lower limit (high byte) | Hz (BCD) | If both addresses contain FF(H), tone detection is disabled. |
| 680416 | PSTN busy tone frequency lower limit (low byte) | | |
| 680417 | PABX dial tone frequency upper limit (high byte) | Hz (BCD) | If both addresses contain FF(H), tone detection is disabled. |
| 680418 | PABX dial tone frequency upper limit (low byte) | | |
| 680419 | PABX dial tone frequency lower limit (high byte) | Hz (BCD) | If both addresses contain FF(H), tone detection is disabled. |
| 68041A | PABX dial tone frequency lower limit (low byte) | | |

| Address | Function | Unit | Remarks |
|---------|---|----------|---|
| 68041B | PABX dial tone detection time | 20 ms | If 68041B contains FF, the machine pauses for the pause time (680420 / 680421). |
| 68041C | PABX dial tone reset time (LOW) | | |
| 68041D | PABX dial tone reset time (HIGH) | | |
| 68041E | PABX dial tone continuous tone time | | |
| 68041F | PABX dial tone permissible drop time | | |
| 680420 | PABX wait interval (HIGH) | | |
| 680421 | PABX wait interval (LOW) | | |
| 680422 | PABX ringback tone detection time | 20 ms | If both addresses contain FF(H), tone detection is disabled. |
| 680423 | PABX ringback tone off detection time | 20 ms | |
| 680424 | PABX detection time for silent period after ringback tone detected (LOW) | 20 ms | If both addresses contain FF(H), tone detection is disabled. |
| 680425 | PABX detection time for silent period after ringback tone detected (HIGH) | 20 ms | |
| 680426 | PABX busy tone frequency upper limit (high byte) | Hz (BCD) | If both addresses contain FF(H), tone detection is disabled. |
| 680427 | PABX busy tone frequency upper limit (low byte) | | |
| 680428 | PABX busy tone frequency lower limit (high byte) | Hz (BCD) | If both addresses contain FF(H), tone detection is disabled. |
| 680429 | PABX busy tone frequency lower limit (low byte) | | |
| 68042A | Busy tone ON time: range 1 | 20 ms | |
| 68042B | Busy tone OFF time: range 1 | | |
| 68042C | Busy tone ON time: range 2 | | |
| 68042D | Busy tone OFF time: range 2 | | |
| 68042E | Busy tone ON time: range 3 | | |
| 68042F | Busy tone OFF time: range 3 | | |
| 680430 | Busy tone ON time: range 4 | | |
| 680431 | Busy tone OFF time: range 4 | | |
| 680432 | Busy tone continuous tone detection time | | |

| Address | Function | Unit | Remarks | | | | | | | | | | | | | | | | | | | | | | |
|---------|--|----------|---|--|--|--|--|---|---|-----|--|--|---|---|-----|--|---|---|-----|--|---|---|-------|--|--|
| 680433 | <p>Busy tone signal state time tolerance for all ranges, and number of cycles required for detection (a setting of 4 cycles means that ON-OFF-ON or OFF-ON-OFF must be detected twice).</p> <p>Tolerance (\pm)</p> <table border="0"> <tr> <td>Bit</td> <td>1</td> <td>0</td> <td></td> <td></td> </tr> <tr> <td></td> <td>0</td> <td>0</td> <td>75%</td> <td rowspan="4">Bits 2 and 3 must always be kept at 0.</td> </tr> <tr> <td></td> <td>0</td> <td>1</td> <td>50%</td> </tr> <tr> <td></td> <td>1</td> <td>0</td> <td>25%</td> </tr> <tr> <td></td> <td>1</td> <td>1</td> <td>12.5%</td> </tr> </table> <p>Bits 7, 6, 5, 4 - number of cycles required for cadence detection</p> | Bit | 1 | 0 | | | | 0 | 0 | 75% | Bits 2 and 3 must always be kept at 0. | | 0 | 1 | 50% | | 1 | 0 | 25% | | 1 | 1 | 12.5% | | |
| Bit | 1 | 0 | | | | | | | | | | | | | | | | | | | | | | | |
| | 0 | 0 | 75% | Bits 2 and 3 must always be kept at 0. | | | | | | | | | | | | | | | | | | | | | |
| | 0 | 1 | 50% | | | | | | | | | | | | | | | | | | | | | | |
| | 1 | 0 | 25% | | | | | | | | | | | | | | | | | | | | | | |
| | 1 | 1 | 12.5% | | | | | | | | | | | | | | | | | | | | | | |
| 680434 | International dial tone frequency upper limit (high byte) | Hz (BCD) | If both addresses contain FF(H), tone detection is disabled. | | | | | | | | | | | | | | | | | | | | | | |
| 680435 | International dial tone frequency upper limit (low byte) | | | | | | | | | | | | | | | | | | | | | | | | |
| 680436 | International dial tone frequency lower limit (high byte) | Hz (BCD) | If both addresses contain FF(H), tone detection is disabled. | | | | | | | | | | | | | | | | | | | | | | |
| 680437 | International dial tone frequency lower limit (low byte) | | | | | | | | | | | | | | | | | | | | | | | | |
| 680438 | International dial tone detection time | 20 ms | If 680438 contains FF, the machine pauses for the pause time (68043D / 68043E). Belgium: See Note 2. | | | | | | | | | | | | | | | | | | | | | | |
| 680439 | International dial tone reset time (LOW) | | | | | | | | | | | | | | | | | | | | | | | | |
| 68043A | International dial tone reset time (HIGH) | | | | | | | | | | | | | | | | | | | | | | | | |
| 68043B | International dial tone continuous tone time | | | | | | | | | | | | | | | | | | | | | | | | |
| 68043C | International dial tone permissible drop time | | | | | | | | | | | | | | | | | | | | | | | | |
| 68043D | International dial wait interval (HIGH) | | | | | | | | | | | | | | | | | | | | | | | | |
| 68043E | International dial wait interval (LOW) | | | | | | | | | | | | | | | | | | | | | | | | |
| 68043F | Country dial tone upper frequency limit (HIGH) | Hz (BCD) | If both addresses contain FF(H), tone detection is disabled. | | | | | | | | | | | | | | | | | | | | | | |
| 680440 | Country dial tone upper frequency limit (LOW) | | | | | | | | | | | | | | | | | | | | | | | | |
| 680441 | Country dial tone lower frequency limit (HIGH) | | If both addresses contain FF(H), tone detection is disabled. | | | | | | | | | | | | | | | | | | | | | | |
| 680442 | Country dial tone lower frequency limit (LOW) | | | | | | | | | | | | | | | | | | | | | | | | |

| Address | Function | Unit | Remarks |
|---------|--|------------|--|
| 680443 | Country dial tone detection time | 20 ms | If 680443 contains FF, the machine pauses for the pause time (680448 / 680449). |
| 680444 | Country dial tone reset time (LOW) | | |
| 680445 | Country dial tone reset time (HIGH) | | |
| 680446 | Country dial tone continuous tone time | | |
| 680447 | Country dial tone permissible drop time | | |
| 680448 | Country dial wait interval (LOW) | | |
| 680449 | Country dial wait interval (HIGH) | | |
| 68044A | Time between opening or closing the DO relay and opening the OHDI relay | 1 ms | See Notes 3 and 6. Function 06-2 (parameter 11). |
| 68044B | Break time for pulse dialing | 1 ms | See Note 3. Function 06-2 (parameter 12). |
| 68044C | Make time for pulse dialing | 1 ms | See Note 3. Function 06-2 (parameter 13). |
| 68044D | Time between final OHDI relay closure and DO relay opening or closing | 1 ms | See Notes 6. Function 06-2 (parameter 14). This parameter is only valid in Europe. |
| 68044E | Minimum pause between dialed digits (pulse dial mode) | 20 ms | See Note 3. Function 06-2 (parameter 15). |
| 68044F | Time waited when a pause is entered at the operation panel | | Function 06-2 (parameter 16). |
| 680450 | DTMF tone on time | 1 ms | Function 06-2 (parameter 17). |
| 680451 | DTMF tone off time | | Function 06-2 (parameter 18). |
| 680452 | Tone attenuation level of DTMF signals while dialing | -dBm x 0.5 | Function 06-2 (parameter 19). See Note 5. |
| 680453 | Tone attenuation value difference between high frequency tone and low frequency tone in DTMF signals | -dBm x 0.5 | Function 06-2 (parameter 20). The setting must be less than -5dBm, and should not exceed the setting at 680452h above. See Note 5. |
| 680454 | PSTN: DTMF tone attenuation level after dialling | -dBm x 0.5 | Function 06-2 (parameter 21). See Note 5. |
| 680455 | ISDN: DTMF tone attenuation level after dialling | -dBm x 0.5 | See Note 5 |

| Address | Function | Unit | Remarks |
|------------------------|--|---|---|
| 680456 | Not used | | Do not change the settings. |
| 680457 | Time between 68044Dh (NCU parameter 14) and 68044Eh (NCU parameter 15) | 1 ms | This parameter takes effect when the country code is set to France. |
| 680458 | Not used | | Do not change the setting. |
| 680459 | Grounding time (ground start mode) | 20 ms | The Gs relay is closed for this interval. |
| 68045A | Break time (flash start mode) | 1 ms | The OHDI relay is open for this interval. |
| 68045B | International dial access code (High) | BCD | For a code of 100: 68045B - F1 68045C - 00 |
| 68045C | International dial access code (Low) | | |
| 68045D | PSTN access pause time | 20 ms | This time is waited for each pause input after the PSTN access code. If this address contains FF[H], the pause time stored in address 68044F is used. Do not set a number more than 7 in the UK. |
| 68045E | Progress tone detection level, and cadence detection enable flags | Bit 7 Bit 6 Bit 5 dBm 0 0 0 -25.0 0 0 1 -35.0 0 1 0 -30.0 1 0 0 -40.0 1 1 0 -49.0 Bits 2, 0 - See Note 3. | |
| 68045F to 680464 | Not used | | Do not change the settings. |
| 680465 | Long distance call prefix (HIGH) | BCD | For a code of 0: 680465 - FF 680466 - F0 |
| 680466 | Long distance call prefix (LOW) | BCD | |
| 680467 to 680471 | Not used | | Do not change the settings. |

| Address | Function | Unit | Remarks | | | | | | | | | | | | | | | | | | | | | | | | | | | | | | | | |
|------------------|--|---------------|--|----------|----------------|--|---|---|--------|--|---|---|--------|--|-------|--|----------|------------|----------|----------|----------------|--|---|---|--------|--|---|---|--------|--|-------|--|----------|--|--|
| 680472 | Acceptable ringing signal frequency: range 1, upper limit | 1000/ N (Hz). | Function 06-2 (parameter 02). | | | | | | | | | | | | | | | | | | | | | | | | | | | | | | | | |
| 680473 | Acceptable ringing signal frequency: range 1, lower limit | | Function 06-2 (parameter 03). | | | | | | | | | | | | | | | | | | | | | | | | | | | | | | | | |
| 680474 | Acceptable ringing signal frequency: range 2, upper limit | | Function 06-2 (parameter 04). | | | | | | | | | | | | | | | | | | | | | | | | | | | | | | | | |
| 680475 | Acceptable ringing signal frequency: range 2, lower limit | | Function 06-2 (parameter 05). | | | | | | | | | | | | | | | | | | | | | | | | | | | | | | | | |
| 680476 | Number or rings until a call is detected | 1 | Function 06-2 (parameter 06). The setting must not be zero. | | | | | | | | | | | | | | | | | | | | | | | | | | | | | | | | |
| 680477 | Minimum required length of the first ring | 20 ms | See Note 4. Function 06-2 (parameter 07). | | | | | | | | | | | | | | | | | | | | | | | | | | | | | | | | |
| 680478 | Minimum required length of the second and subsequent rings | 20 ms | Function 06-2 (parameter 06-2). | | | | | | | | | | | | | | | | | | | | | | | | | | | | | | | | |
| 680479 | Ringing signal detection reset time (LOW) | 20 ms | Function 06-2 (parameter 09). | | | | | | | | | | | | | | | | | | | | | | | | | | | | | | | | |
| 68047A | Ringing signal detection reset time (HIGH) | | Function 06-2 (parameter 10). | | | | | | | | | | | | | | | | | | | | | | | | | | | | | | | | |
| 68047B to 680480 | Not used | | Do not change the settings. | | | | | | | | | | | | | | | | | | | | | | | | | | | | | | | | |
| 680481 | Interval between dialing the last digit and switching the Oh relay over to the external telephone when dialing from the operation panel in handset mode. | 20 ms | Factory setting: 500 ms | | | | | | | | | | | | | | | | | | | | | | | | | | | | | | | | |
| 680482 | <p>Bits 0 and 1 - Handset off-hook detection time</p> <table border="0"> <tr> <td>Bit</td> <td>1</td> <td>0</td> <td>Setting</td> </tr> <tr> <td></td> <td>0</td> <td>0</td> <td>200 ms</td> </tr> <tr> <td></td> <td>0</td> <td>1</td> <td>800 ms</td> </tr> <tr> <td></td> <td>Other</td> <td></td> <td>Not used</td> </tr> </table> <p>Bits 2 and 3 - Handset on-hook detection time</p> <table border="0"> <tr> <td>Bit</td> <td>3</td> <td>2</td> <td>Setting</td> </tr> <tr> <td></td> <td>0</td> <td>0</td> <td>200 ms</td> </tr> <tr> <td></td> <td>0</td> <td>1</td> <td>800 ms</td> </tr> <tr> <td></td> <td>Other</td> <td></td> <td>Not used</td> </tr> </table> <p>Bits 4 to 7 - Not used</p> | Bit | 1 | 0 | Setting | | 0 | 0 | 200 ms | | 0 | 1 | 800 ms | | Other | | Not used | Bit | 3 | 2 | Setting | | 0 | 0 | 200 ms | | 0 | 1 | 800 ms | | Other | | Not used | | |
| Bit | 1 | 0 | Setting | | | | | | | | | | | | | | | | | | | | | | | | | | | | | | | | |
| | 0 | 0 | 200 ms | | | | | | | | | | | | | | | | | | | | | | | | | | | | | | | | |
| | 0 | 1 | 800 ms | | | | | | | | | | | | | | | | | | | | | | | | | | | | | | | | |
| | Other | | Not used | | | | | | | | | | | | | | | | | | | | | | | | | | | | | | | | |
| Bit | 3 | 2 | Setting | | | | | | | | | | | | | | | | | | | | | | | | | | | | | | | | |
| | 0 | 0 | 200 ms | | | | | | | | | | | | | | | | | | | | | | | | | | | | | | | | |
| | 0 | 1 | 800 ms | | | | | | | | | | | | | | | | | | | | | | | | | | | | | | | | |
| | Other | | Not used | | | | | | | | | | | | | | | | | | | | | | | | | | | | | | | | |
| 680483 to 6804A0 | Not used | | Do not change the settings. | | | | | | | | | | | | | | | | | | | | | | | | | | | | | | | | |

| Address | Function | Unit | Remarks |
|---------|---|--|--|
| 6804A1 | Acceptable CED detection frequency upper limit (high byte) | BCD (Hz) | If both addresses contain FF(H), tone detection is disabled. |
| 6804A2 | Acceptable CED detection frequency upper limit (low byte) | | |
| 6804A3 | Acceptable CED detection frequency lower limit (high byte) | BCD (Hz) | If both addresses contain FF(H), tone detection is disabled. |
| 6804A4 | Acceptable CED detection frequency lower limit (low byte) | | |
| 6804A5 | CED detection time | 20 ms ± 20 ms | Factory setting: 200 ms |
| 6804A6 | Acceptable CNG detection frequency upper limit (high byte) | BCD (Hz) | If both addresses contain FF(H), tone detection is disabled. |
| 6804A7 | Acceptable CNG detection frequency upper limit (low byte) | | |
| 6804A8 | Acceptable CNG detection frequency lower limit (high byte) | BCD (Hz) | If both addresses contain FF(H), tone detection is disabled. |
| 6804A9 | Acceptable CNG detection frequency lower limit (low byte) | | |
| 6804AA | Not used | | Do not change the setting. |
| 6804AB | CNG on time | 20 ms | Factory setting: 500 ms |
| 6804AC | CNG off time | 20 ms | Factory setting: 200 ms |
| 6804AD | Number of CNG cycles required for detection | | The data is coded in the same way as address 680433. |
| 6804AE | Not used | | Do not change the settings. |
| 6804AF | Acceptable AI short protocol tone (800Hz) detection frequency upper limit (high byte) | Hz (BCD) | If both addresses contain FF(H), tone detection is disabled. |
| 6804B0 | Acceptable AI short protocol tone (800Hz) detection frequency upper limit (low byte) | | |
| 6804B1 | Acceptable AI short protocol tone (800Hz) detection frequency lower limit (high byte) | Hz(BCD) | If both addresses contain FF(H), tone detection is disabled. |
| 6804B2 | Acceptable AI short protocol tone (800Hz) detection frequency lower limit (low byte) | | |
| 6804B3 | Detection time for 800 Hz AI short protocol tone | 20 ms | Factory setting: 360 ms |
| 6804B4 | PSTN: Tx level from the modem | - dBm | Function 06-2 (parameter 01). |
| 6804B5 | PSTN: 1100 Hz tone transmission level | - N 6804B4 - 0.5N 6804B5 (dB) See Note 7. | |
| 6804B6 | PSTN: 2100 Hz tone transmission level | - N6804B4 - 0.5N 6804B6 (dB) See Note 7. | |
| 6804B7 | PABX: Tx level from the modem | - dBm | |

| Address | Function | Unit | Remarks |
|------------------|---|------------------------------------|--|
| 6804B8 | PABX: 1100 Hz tone transmission level | - N 6804B7 - 0.5N 6804B8 (dB) | |
| 6804B9 | PABX: 2100 Hz tone transmission level | - N 6804B7 - 0.5N 6804B9 (dB) | |
| 6804BA | ISDN: Tx level from the modem | - dBm | The setting must be between -12dBm and -15dBm. |
| 6804BB | ISDN: 1100 Hz tone transmission level | - N 6804BA - 0.5N 6804BB (dB) | |
| 6804BC | ISDN: 2100 Hz tone transmission level | - N 6804BA - 0.5N 6804BC (dB) | |
| 6804BD | Modem turn-on level (incoming signal detection level) | -37-0.5N (dBm) | |
| 6804BE to 6804C6 | Not used | | Do not change the settings. |
| 6804C7 | Bits 0 to 3 – Not used. Bit 4 – V.34 protocol dump 0 : Simple, 1 : Detailed (default) Bits 5 to 7 – Not used. | | |
| 6804C8 to 6804D9 | Not used | | Do not change the settings. |
| 6804DA | T.30 T1 timer | 1 s | |
| 6804E0 bit 3 | Maximum wait time for post message | 0 : 12 s 1 : 30 s | 1 : Maximum wait time for post message (EOP/EOM/MPS) can be changed to 30 s. Change this bit to “1” if communication errors occur frequently during V.17 reception. |

NOTES

1. If a setting is not required, store FF in the address.
2. Italy and Belgium only

RAM address 68045E: the lower four bits have the following meaning.

Bit 2 - 1: International dial tone cadence detection enabled (Belgium)

Bit 1 - Not used

Bit 0 - 1: PSTN dial tone cadence detection enabled (Italy)

If bit 0 or bit 2 is set to 1, the functions of the following RAM addresses are changed.

680408 (if bit 0 = 1) or 680438 (if bit 2 = 1): tolerance for on or off state duration (%), and number of cycles required for detection, coded as in address 680433.

68040B (if bit 0 = 1) or 68043B (if bit 2 = 1): on time, hex code (unit = 20 ms)

68040C (if bit 0 = 1) or 68043C (if bit 2 = 1): off time, hex code (unit = 20 ms)

3. Pulse dial parameters (addresses 68044A to 68044F) are the values for 10 pps. If 20 pps is used, the machine automatically compensates.
4. The first ring may not be detected until 1 to 2.5 wavelengths after the time specified by this parameter.
5. The calculated level must be between 0 and 10.
The attenuation levels calculated from RAM data are:
High frequency tone: $- 0.5 \times N_{680452/680454/680455}$ dBm
Low frequency tone: $- 0.5 \times (N_{680452/680454/680455} + N_{680453})$ dBm
Note: N_{680452} , for example, means the value stored in address 680452(H)
6. 68044A: Europe - Between Ds opening and Di opening, France - Between Ds closing and Di opening
68044D: Europe - Between Ds closing and Di closing, France - Between Ds opening and Di closing
7. Tone signals which frequency is lower than 1500Hz (e.g., 800Hz tone for AI short protocol) refer to the setting at 6804B5h. Tones which frequency is higher than 1500Hz refer to the setting at 6804B6h.

4.4 DEDICATED TRANSMISSION PARAMETERS

Each Quick Dial Key and Speed Dial Code has eight bytes of programmable parameters allocated to it. If transmissions to a particular machine often experience problems, store that terminal's fax number as a Quick Dial or Speed Dial, and adjust the parameters allocated to that number.

The programming procedure will be explained first. Then, the eight bytes will be described.

4.4.1 PROGRAMMING PROCEDURE

1. Make sure the machine is in 'Facsimile' mode. Press 'User Tools' key then choose 'Fax'.
2. Press 1, then either choose 'Registering Quick Dial' or 'Registering Speed Dial'.
Example: Change the Parameters in Quick Dial 10.
3. Press Quick Dial key 10.
NOTE: The selected Quick or Speed Dial must be programmed beforehand.
4. When the programmed dial number is displayed, press S - V - C using Quick Dial keys, then press 'Start'.
5. The settings for byte 0 are now displayed. Press a number from 0 to 7 corresponding to the bit that you wish to change.
Example: Change bit 7 to 1: Press 7
6. To scroll through the parameter bytes, either:
Select the next byte: press '↓ Switch'
or
Select the previous byte: press '↑ Switch' until the correct byte is displayed.
Then go back to step 6.
7. After the setting is changed, press OK.
8. To finish, press 'User Tools'.

4.4.2 PARAMETERS

The initial settings of the following parameters are all FF(H) - all the parameters are disabled.

| | |
|---|--|
| Switch 01 | |
| FUNCTION AND COMMENTS | |
| ITU-T T1 time (for PSTN G3 mode) | |
| If the connection time to a particular terminal is longer than the NCU parameter setting, adjust this byte. The T1 time is the value stored in this byte (in hex code), multiplied by 1 second. | |
| Range: | |
| 0 to 120 s (00h to 78h) | |
| FFh - The local NCU parameter factory setting is used. | |
| Do not program a value between 79h and FEh. | |

| Switch 02 | | |
|------------------|------------------------------|---|
| No | FUNCTION | COMMENTS |
| 0 | Tx level | If communication with a particular remote terminal often contains errors, the signal level may be inappropriate. Adjust the Tx level for communications with that terminal until the results are better. If the setting is 'Disabled', the NCU parameter 01 setting is used. Note: Do not use settings other than listed on the left. |
| to | Bit 4 3 2 1 0 Setting | |
| 4 | 0 0 0 0 0 0 | |
| | 0 0 0 0 1 -1 | |
| | 0 0 0 1 0 -2 | |
| | 0 0 0 1 1 -3 | |
| | 0 0 1 0 0 -4 | |
| | : | |
| | : | |
| | 0 1 1 1 1 -15 | |
| | 1 1 1 1 1 Disabled | |
| 5 | Cable equalizer | Use a higher setting if there is signal loss at higher frequencies because of the length of wire between the modem and the telephone exchange when calling the number stored in this Quick/Speed Dial. Also, try using the cable equalizer if one or more of the following symptoms occurs. <ul style="list-style-type: none"> • Communication error with error codes such as 0-20, 0-23, etc. • Modem rate fallback occurs frequently. Note: Do not use settings other than listed on the left. If the setting is 'Disabled', the bit switch setting is used. |
| to | Bit 7 6 5 Setting | |
| 7 | 0 0 0 None | |
| | 0 0 1 Low | |
| | 0 1 0 Medium | |
| | 0 1 1 High | |
| | 1 1 1 Disabled | |

| Switch 03 | | |
|-----------------------------------|---|--|
| No | FUNCTION | COMMENTS |
| 0 to 3 | Initial Tx modem rate Bit 3 2 1 0 Setting (bps) 0 0 0 0 Not used 0 0 0 1 2,400 0 0 1 0 4,800 0 0 1 1 7,200 0 1 0 0 9,600 0 1 0 1 12,000 0 1 1 0 14,400 0 1 1 1 16,800 1 0 0 0 19,200 1 0 0 1 21,600 1 0 1 0 24,000 1 0 1 1 26,400 1 1 0 0 28,800 1 1 0 1 31,200 1 1 1 0 33,600 1 1 1 1 Disabled Other settings: Not used | If training with a particular remote terminal always takes too long, the initial modem rate may be too high. Reduce the initial Tx modem rate using these bits. For the settings 14.4 or kbps slower, Switch 04 bit 4 must be changed to 0. Note: Do not use settings other than listed on the left. If the setting is 'Disabled', the bit switch setting is used. |
| 4-5 | Not used | Do not change the settings. |
| 6 | AI short protocol 0: Off 1: Disabled | Refer to Appendix B in the Group 3 Facsimile Manual for details about AI Short Protocol. If the setting is 'Disabled', the bit switch setting is used. |
| 7 | Not used | Do not change the settings. |

| Switch 04 | | |
|-----------------------------------|---|---|
| No | FUNCTION | COMMENTS |
| 0 1 | Inch-mm conversion before tx Bit 1 Bit 0 Setting 0 0 Inch-mm conversion available 0 1 Inch only 1 0 Not used 1 1 Disabled | The machine uses inch-based resolutions for scanning. If "inch only" is selected, the printed copy may be slightly distorted at the other end if that machine uses mm-based resolutions. If the setting is 'Disabled', the bit switch setting is used. |
| 2 to 3 | DIS/NSF detection method Bit 3 Bit 2 Setting 0 0 First DIS or NSF 0 1 Second DIS or NSF 1 0 Not used 1 1 Disabled | (0, 1): Use this setting if echoes on the line are interfering with the set-up protocol at the start of transmission. The machine will then wait for the second DIS or NSF before sending DCS or NSS. If the setting is 'Disabled', the bit switch setting is used. |

Service Tables

| Switch 04 | | |
|----------------------|--|---|
| No | FUNCTION | COMMENTS |
| 4 | V.8 protocol 0: Off 1: Disabled | If transmissions to a specific destination always end at a lower modem rate (14,400 bps or lower), disable V.8 protocol so as not to use V.34 protocol. 0: V.34 communication will not be possible. If the setting is 'Disabled', the bit switch setting is used. |
| 5 | Compression modes available in transmit mode 0: MH only 1: Disabled | This bit determines the capabilities that are informed to the other terminal during transmission. If the setting is 'Disabled', the bit switch setting is used. |
| 6 7 | ECM during transmission Bit 7 Bit 6 Setting 0 0 Off 0 1 On 1 0 Not used 1 1 Disabled | For example, if ECM is switched on but is not wanted when sending to a particular terminal, use the (0, 0) setting. Note that V.8/V.34 protocol and JBIG compression are automatically disabled if ECM is disabled. If the setting is 'Disabled', the bit switch setting is used. |

Switch 05 - Not used (do not change the settings)

Switch 06 - Not used (do not change the settings)

Switch 07 - Optional ISDN G4 kit required

| No | FUNCTION | COMMENTS |
|-----------------------------------|--|--|
| 0 to 3 | Data rate Bits 3 2 1 0 Setting 0 0 0 0 64 kbps 0 0 0 1 56 kbps 1 1 1 1 Disabled | If the setting is 'Disabled', the current setting of G4 parameter switch 2 (bits 0 and 1) is used. |
| 4-7 | Not used | Do not change the settings. |

Switch 08 - Optional ISDN G4 kit required

| No | FUNCTION | COMMENTS |
|-----------------------------------|---|---|
| 0 to 3 | Link modulus Bits 3 2 1 0 Setting 0 0 0 0 Modulo 8 0 0 0 1 Modulo 128 1 1 1 1 Disabled | If the setting is 'Disabled', the current setting of G4 parameter switch 3 (bit 0) is used. |
| 4-7 | Not used | Do not change the settings. |

| Switch 09 - Optional ISDN G4 kit required | | |
|--|--|---|
| No | FUNCTION | COMMENTS |
| 0 to 3 | Layer 3 protocol Bits 3 2 1 0 Setting 0 0 0 0 ISO 8208 0 0 0 1 T.70 NULL 1 1 1 1 Disabled | If the setting is 'Disabled', the current setting of G4 parameter switch 6 (bit 0) is used. |
| 4 to 7 | Packet modulus Bits 3 2 1 0 Setting 0 0 0 0 Modulo 8 0 0 0 1 Modulo 128 1 1 1 1 Disabled | If the setting is 'Disabled', the current setting of G4 parameter switch 6 (bit 4) is used. |

Switch 0A - Not used

4.5 SERVICE RAM ADDRESSES

| |
|--|
| ⚠ CAUTION |
| Do not change the settings which are marked as “Not used” or “Read only.” |

680001 to 680004(H) - ROM version (Read only)

680001(H) - Revision number (BCD)

680002(H) - Year (BCD)

680003(H) - Month (BCD)

680004(H) - Day (BCD)

680006 to 680015(H) - Machine's serial number (16 digits - ASCII)

680018(H) - Total program checksum (low)

680019(H) - Total program checksum (high)

680020 to 68003F(H) - System bit switches

680040 to 68004F(H) - Scanner bit switches

680050 to 68005F(H) - Printer bit switches

680060 to 68007F(H) - Communication bit switches

680080 to 68008F(H) - G3 bit switches

6800C0(H) - User parameter switch 00 (SWUER_00)

Bit 0: Stamp home position 0: Disabled, 1: Enabled

Bits 1 to 3: Scanning contrast home position

| Bit | 3 | 2 | 1 | Setting |
|-----|---|---|---|-----------------------|
| | 0 | 0 | 0 | Automatic |
| | 0 | 0 | 1 | Position 1 (Lightest) |
| | 0 | 1 | 0 | Position 2 |
| | 0 | 1 | 1 | Position 3 |
| | 1 | 0 | 0 | Position 4 (Medium) |
| | 1 | 0 | 1 | Position 5 |
| | 1 | 1 | 0 | Position 6 |
| | 1 | 1 | 1 | Position 7 (Darkest) |

Bits 4 and 5: Scanning resolution home position

(This switch is not printed on the user parameter list.)

| Bit | 5 | 4 | Setting |
|-----|---|---|-----------|
| | 0 | 0 | Standard |
| | 0 | 1 | Detail |
| | 1 | 0 | Superfine |
| | 1 | 1 | Superfine |

Bit 6: Transmission mode home position

(This switch is not printed on the user parameter list.)

0: Memory tx, 1: Immediate tx

Bit 7: Not used

6800C1(H) - User parameter switch 01 (SWUSR_01)

Bit 0: Label insertion home position 0: Disabled, 1: Enabled
 Bit 1: ID transmission home position 0: Disabled, 1: Enabled
 Bit 2: Automatic reduction (tx) home position 0: Disabled, 1: Enabled
 Bits 3 and 4: Scanning mode LED home position
 (This switch is not printed on the user parameter list.)

| | | | |
|-----|---|---|---------------------------------------|
| Bit | 4 | 3 | Setting |
| | 0 | 0 | Text |
| | 0 | 1 | Text/ Photo |
| | 1 | 0 | Photo |
| | 1 | 1 | Special Original (See the note below) |

Note: The “Special Original” setting is not explained in the Operator’s Manual, because it can be selected only if System Switch 19 – bit 7 is set to “1”.

Bit 5: TTI print home position 0: Disabled, 1: Enabled
 Bit 6: TTI used for broadcasting; the TTI selected with this switch is used for all destinations during broadcasting.

0: TTI_1, **1:** TTI_2

(This switch is not printed on the user parameter list.)

Note: System Switch 11 bit 3 must be set to “1” to enable this switch.

Bit 7: Settings return to home position after scanning 0: Disabled, 1: Enabled

6800C2(H) - User parameter switch 02 (SWUSR_02)

Bit 0: Forwarding mark printing on forwarded messages 0: Disabled, 1: Enabled
 Bit 1: Center mark printing on received copies
 (This switch is not printed on the user parameter list.)

0: Disabled, **1:** Enabled

Bit 2: Reception time printing
 (This switch is not printed on the user parameter list.)

0: Disabled, **1:** Enabled

Bit 3: TSI print on received messages 0: Disabled, 1: Enabled

Bit 4: Checkered mark printing
 (This switch is not printed on the user parameter list.)

0: Disabled, **1:** Enabled

Bit 5: CIL printing (G4) 0: Disabled, 1: Enabled

Bit 6: TID printing (G4) 0: Disabled, 1: Enabled

Bit 7: Not used

6800C3(H) - User parameter switch 03 (SWUSR_03: Automatic report printout)

Bit 0: Transmission result report (memory transmissions) 0: Off, 1: On

Bit 1: Not used

Bit 2: Memory storage report 0: Off, 1: On

Bit 3: Polling reserve report (polling reception) 0: Off, 1: On

Bit 4: Polling result report (polling reception) 0: Off, 1: On

Bit 5: Transmission result report (immediate transmissions) 0: Off, 1: On

Bit 6: Polling clear report 0: Off, 1: On

Bit 7: Journal 0: Off, 1: On

6800C4(H) - User parameter switch 04 (SWUSR_04: Automatic report printout)

Bit 0: Automatic confidential reception report output 0: Off, 1: On

Bits 1 to 6: Not used

Bit 7: Inclusion of a sample image on reports 0: Off, 1: On

6800C5(H) - User parameter switch 05 (SWUSR_05)

Bit 0: Substitute reception when the base copier is in an SC condition
0: Enabled, 1: Disabled

Bits 1 and 2: Condition for substitute rx when the machine cannot print messages
(Paper end, Toner end, and Jam during night mode)

| Bit | 2 | 1 | Setting |
|-----|---|---|--|
| | 0 | 0 | The machine receives all the fax messages. |
| | 0 | 1 | The machine receives the fax messages with RTI or CSI. |
| | 1 | 0 | The machine receives the fax messages with the same ID code. |
| | 1 | 1 | The machine does not receive anything. |

Bit 3: Not used

Bit 4: Restricted Access using personal codes 0: Off, 1: On

Bit 5: Just size printing 0: Off, 1: On

Bit 6: Not used

Bit 7: Add paper display when a cassette is empty 0: Off, 1: On

6800C6(H) - User parameter switch 06 (SWUSR_06)

Bit 0: Not used

Bit 1: G3/G4 LED home position 0: G3, 1: G4

Bits 2 and 3: Not used

Bit 4: Quick dial label print format
0: Suitable for white paper, 1: Suitable for transparent paper

Bit 5: Not used

Bit 6: Scan sequence in Book transmission
0: Left page then right page, 1: Right page then left page

Bit 7: Not used

6800C7(H) - User parameter switch 07 (SWUSR_07)

Bits 0 and 1: Not used

Bit 2: Parallel memory transmission 0: Off, 1: On

Bits 3 to 7: Not used

6800C8(H) - User parameter switch 08 (SWUSR_08)

Bits 0 and 1: Not used.

Bit 2: Authorized reception
0: Only faxes from senders whose RTIs/CSIs are specified for this feature are accepted.
1: Only faxes from senders whose RTIs/CSIs are not specified for this feature are accepted.

Bits 3 to 7: Not used.

6800C9(H) - User parameter switch 09 (SWUSR_09)

Bits 0 to 7: Not used

6800CA(H) - User parameter switch 10 (SWUSR_0A)

Bit 0: Not used

Bit 1: 2 into 1 0: Off, 1: On

Bit 2: Not used

Bit 3: Page reduction 0: Off, 1: On

Bits 4 to 7: Not used

6800CB(H) - User parameter switch 11 (SWUSR_0B)

Bit 0: Not used

Bit 1: Method of transmitting numbers after the "Tone" mark over an ISDN line
0: UII, 1: Tone

Bits 2 to 5: Not used

Bit 6: Printout of messages received while acting as a forwarding station
0: Off, 1: On

Bit 7: Polling Standby duration 0: Once, 1: No limit

6800CC(H) - User parameter switch 12 (SWUSR_0C)

Bits 0 to 7: Not used

6800CD(H) - User parameter switch 13 (SWUSR_0D)

(This switch is not printed on the user parameter list.)

Bits 0 and 1: PSTN access method from behind a PABX

| | | | |
|-----|---|---|--------------|
| Bit | 1 | 0 | Setting |
| | 0 | 0 | PSTN |
| | 0 | 1 | Loop start |
| | 1 | 0 | Ground start |
| | 1 | 1 | Flash start |

Bits 2 to 4: Not used

Bit 5: Action when receiving a SETUP signal containing no called number and the G4 subscriber number was programmed in this machine.

0: Respond to the call, 1: Do not respond to the call

Bit 6: Action when the received HLC (Higher Level Capabilities) is Tel or BC (Bearer Capabilities) is Speech.

0: Do not respond to the call, 1: Respond to the call

This switch determines which information transfer capabilities the machine can accept when receiving a call.

1: When the received HLC is Tel (digital telephone) or BC is Speech (voice), the machine responds to the call. In short, the machine receives every call.

This switch is useful for communication problems when the other terminal informs the above transfer capabilities although it is a fax machine.

Bit 7: Not used

6800CE(H) - User parameter switch 14 (SWUSR_0E)

Bit 0: Message printout while the machine is in Night Timer mode 0: On, 1: Off

Bit 1: Maximum document length detection (Well log)

0: Double letter, 1: 1200 mm (Memory transmission)

Bit 2: Batch transmission 0: Off, 1: On

Bit 3: Setting before mode key (Copy/Fax/Printer) is pressed

0: Not cleared, 1: Cleared

Bits 4 to 6: Not used

Bit 7: Manual service call (sends the system parameter list to the service station)
0: Off, 1: On

6800CF(H) - User parameter switch 15 (SWUSR_0F)

Bits 0, 1 and 2: Cassette for fax printout

| Bit | 2 | 1 | 0 | Setting |
|-----|----------------|---|---|------------------------|
| | 0 | 0 | 1 | 1st paper feed station |
| | 0 | 1 | 0 | 2nd paper feed station |
| | 0 | 1 | 1 | 3rd paper feed station |
| | Other settings | | | Not used |

Bits 3 and 4: Not used

Bit 5: Using the cassette specified by bits 0, 1 and 2 above only 0: On, 1: Off

Bits 6 and 7: Not used

6800D0(H) – User parameter switch 16 (SWUSR_10)

(This switch is not printed on the user parameter list.)

Bits 0 and 1: Not used

Bit 2: Paper size selection priority for an A4 size fax message when A4/LT size paper is not available.

0: A3 has priority, 1: B4 has priority

Bits 3 to 7: Not used

6800D1(H) – User parameter switch 17 (SWUSR_11)

Bits 0 and 1: Not used

Bit 2: Inclusion of the “Add” button when a sequence of Quick/Speed dials is selected for broadcasting

0: Not needed, 1: Needed

Bits 3 to 7: Not used

6800D2(H) - User parameter switch 18 (SWUSR_12)

Bit 0: TTI date 0: Off, 1: On

Bit 1: TTI sender 0: Off, 1: On

Bit 2: TTI file number 0: Off, 1: On

Bit 3: TTI page number 0: Off, 1: On

Bit 4 to 7: Not used

6800D3(H) - User parameter switch 19 (SWUSR_13)

Bit 0: Not used

Bit 1: Journal format

0: The Journal is separated into transmissions and receptions

1: The Journal is separated into G3 communications and G4 communications

Bit 2: Action when the paper cassette, which was selected by the specified cassette selection feature, becomes empty.

(This switch is not printed on the user parameter list.)

0: The machine will not print any received files until the paper is added.

1: The machine will use other cassettes to print received files that are not specified by this feature.

Bit 3: 90° image rotation during B5 portrait Tx

(This switch is not printed on the user parameter list.)

0: Off, 1: On

Bit 4: Reduction of sample images on reports to 50% in the main scan and sub-scan directions. (This switch is not printed on the user parameter list.)

0: Off, 1: On

Bit 5: Use of A5 size paper for reports
 (This switch is not printed on the user parameter list.)
 0: Off, 1: On

Bits 6 and 7: Not used

6800D4(H) - User parameter switch 20 (SWUSR_14)

Bit 0: PC transmission mode
 0: Direct Tx, 1: Memory Tx
 Bit 1: Addition of fax TTI during PC memory transmission
 0: Disabled, 1: Enabled
 Bit 2: Checkered mark on printouts during PC printing
 0: Disabled, 1: Enabled

Bits 3 and 4: Not used

Bit 5: Communication port for PC memory transmission
 (This switch is not printed on the user parameter list.)
 0: PSTN, 1: ISDN G4

Bits 6 and 7: Buffer threshold for PC direct transmission
 Keep this bit at "0,0" in most cases.
 (This switch is not printed on the user parameter list.)

| Bit 7 | Bit 6 | setting |
|-------|-------|-------------------|
| 0 | 0 | Minimum (default) |
| 0 | 1 | : |
| 1 | 0 | : |
| 1 | 1 | Maximum |

6800D5(H) - User parameter switch 21 (SWUSR_15)

Bit 0: PC fax reception 0: Disabled, 1: Enabled

Bits 1 and 2: PC fax reception mode

| Bit 2 | Bit 1 | Setting |
|-------|-------|--|
| 0 | 0 | Direct rx |
| 0 | 1 | Memory rx |
| 1 | 0 | Not used |
| 1 | 1 | Memory rx and print on the fax machine |

Bit 3: Automatic reduction when the machine transfers data to the PC from the machine. This switch is effective only for PC memory Tx.
 (This switch is not printed on the user parameter list.)

0: Enabled, 1: Disabled

Bits 4 and 5: Scan density for the "Light" setting.
 (This switch is effective only when a PC scanner application with the CMF-TWAIN driver is used.)

| Bit 5 | Bit 4 | Setting |
|-------|-------|-------------------|
| 0 | 0 | Level 1 (default) |
| 0 | 1 | Level 1 |
| 1 | 0 | Level 2 |
| 1 | 1 | Level 3 |

Bits 6 and 7: Scan density for the “Dark” setting.

(This switch is effective only when a PC scanner application with the CMF-TWAIN driver is used.)

| Bit 7 | Bit 6 | Setting |
|-------|-------|-------------------|
| 0 | 0 | Level 7 (default) |
| 0 | 1 | Level 5 |
| 1 | 0 | Level 6 |
| 1 | 1 | Level 7 |

6800D6(H) to 6800D7 - User parameter switch 22 to 23 (SWUSR_16 to 17)

Bits 0 to 7: Not used

6800D8(H) - User parameter switch 24 (SWUSR_18)

Bits 0 and 1: File retention time (Cross reference: System switch 02 bit4)

| Bit 1 | 0 | Setting |
|-------|---|----------|
| 0 | 0 | Disabled |
| 0 | 1 | 24 hours |
| 1 | 0 | Disabled |
| 1 | 1 | 72 hours |

Bits 2 to 7: Not used

6800D9(H) - User parameter switch 25 (SWUSR_19)

Bits 0 to 3: Not used

Bit 4: RDS operation 0: Not acceptable

1: Acceptable for the limit specified by system switch 03

Note: This bit is only effective when RDS operation can be selected by the user.

Bits 5 and 6: Not used

Bit 7: Daylight saving time 0: Disabled, 1: Enabled

6800DA(H) - User parameter switch 26 (SWUSR_1A)

(This switch is not printed on the user parameter list.)

Bit 0: Not used

Bit 1: Dialing type 0: Pulse dialing (10 pps), 1: Tone (DTMF) dialing

Bits 2 to 7: Not used

6800DB(H) - User parameter switch 27 (SWUSR_1B)

PSTN access code from behind a PABX

(This switch is not printed on the user parameter list.)

| Access number | Hex value to program (BCD) |
|---------------|----------------------------|
| 0 | F0 |
| ↓ | ↓ |
| 0 | F0 |
| 00 | 00 |
| ↓ | ↓ |
| 99 | 99 |

6800DC(H) to 6800DF - User parameter switch 28 to 31 (SWUSR_1C to 1F)

Bits 0 to 7: Not used

6800E0 to 6800EF(H) - G4 Parameter Switches

(Refer to the ISDN G4 option service manual for details.)

6800F0 to 68010F(H) - G4 Internal Switches

(Refer to the ISDN G4 option service manual for details.)

680110 to 68011E(H) - Service station's fax number (Service mode 09)

See 68027C(H) for the type of network used for this number.

68011F to 68012D(H) - Own fax PABX extension number**68012E to 68013C(H)** - Own fax number (PSTN)**68013D to 68014B(H)** - Own fax number (ISDN G4)**68014C to 68015A(H)** - The first subscriber number (ISDN G3)**68015B to 680169(H)** - The second subscriber number (ISDN G3)**68016A to 680178(H)** - The first subscriber number (ISDN G4)**680179 to 680187(H)** - The second subscriber number (ISDN G4)**680188 to 68019B(H)** - RTI (Max. 20 characters - ASCII) - See the following note.**6801B0 to 6801EF(H)** - TTI 1 (Max. 64 characters - ASCII) - See the following note.**6801F0 to 680229(H)** - TTI 2 (Max. 64 characters - ASCII) - See the following note.**680230 to 680243(H)** - CSI (Max. 20 characters - ASCII)**680258 to 68026B(H)** - ISDN G3 CSI (Max. 20 characters - ASCII)**68026C(H)** - Number of CSI characters (Hex)**68026E(H)** - Number of ISDN G3 CSI characters (Hex)**NOTE:** If the number of characters is less than the maximum (20 for RTI, 64 for TTI), add a stop code (FF[H]) after the last character.**680270(H)** - ID code (low - Hex)**680271(H)** - ID code (high - Hex)**680272(H)** - Confidential ID (low - BCD)**680273(H)** - Confidential ID (high - BCD)**68027C(H)** - Network type used for the service station number

00(H) - G3 (PSTN)

01(H) - G4 (ISDN)

680280 to 680287(H) - Last power off time (Read only)

680280(H) - 01(H) - 24-hour clock, 00(H) - 12-hour clock (AM), 02(H) - 12-hour clock (PM)

680281(H) - Year (BCD)

680282(H) - Month (BCD)

680283(H) - Day (BCD)

680284(H) - Hour

680285(H) - Minute

680286(H) - Second

680287(H) - 00: Monday, 01: Tuesday, 02: Wednesday, , 06: Sunday

680294(H) - Optional equipment (Read only – Do not change the settings)

Bits 0 to 2: EXMEM board 0: Not installed, 1: Installed

Bit 3: Not used

Bit 4: EXFUNC board 0: Not installed, 1: Installed

Bit 5 to 7: Not used

680295(H) - Optional equipment (Read only – Do not change the settings)

Bit 0: EXFUNC board 0: Not installed, 1: Installed

Bits 1 to 5: Not used

Bit 6: ISDN unit 0: Not installed, 1: Installed

Bit 7: PC Fax Expander unit 0: Not installed, 1: Installed

680296(H) - Optional equipment (Read only – Do not change the settings)

Bit 0: Paper tray unit 0: Not installed, 1: Installed

Bits 1 to 3: Not used

Bit 4: 1-bin sorter 0: Not installed, 1: Installed

Bits 5 to 7: Not used

680297(H) - Optional equipment (Read only – Do not change the settings)

Bit 0: Not used

Bit 1: Not used

Bit 2: Document feeder 0: Not installed, 1: Installed

Bit 3: Stamp 0: Not installed, 1: Installed

Bits 4 to 7: Not used

6802CC to 6802E3(H) - G4 terminal ID (ASCII - Max. 24 characters)**6802FD to 680300(H)** - ISDN G3 sub-address**680301 to 680304(H)** - ISDN G4 sub-address**680305 to 680309(H)** - CiG4 board ROM information (Read only)

680305(H) - Suffix

680306(H) - Version (BCD)

680307(H) - Year (BCD)

680308(H) - Month (BCD)

680309(H) - Day (BCD)

680314 to 680319(H) - Modem ROM version (Read only)

680314(H) - Part number (low)

680315(H) - Part number (high)

680316(H) - Control (low)

680317(H) - Control (high)

680318(H) - DSP (low)

680319(H) - DSP (high)

68037E(H) - Time for economy transmission (hour in 24h clock format - BCD)**68037F(H)** - Time for economy transmission (minute - BCD)**68039A(H)** - Transmission monitor volume 00 - 07(H)**68039B(H)** - Reception monitor volume 00 - 07(H)**68039C(H)** - On-hook monitor volume 00 - 07(H)**68039D(H)** - Dialing monitor volume 00 - 07(H)**68039E(H)** - Buzzer volume 00 - 07(H)**6803A1 to 6803A5(H)** - Periodic service call parameters

| Parameters | | Address (H) |
|---|---------------------------|-------------|
| Call interval: 01 through 15 month(s) (BCD) 00: Periodic service call disabled | | 6803A1 |
| Date and time of the next call | Day: 01 through 31 (BCD) | 6803A4 |
| | Hour: 01 through 24 (BCD) | 6803A5 |

6803AB to 6803AD(H) - Effective term of automatic service calls

| Parameters | Address (H) |
|--|---------------|
| Year: last two digits of the year (BCD) | 6803AB |
| Month: 01 through 12 (BCD) | 6803AC |
| Day: 01 through 31 (BCD) | 6803AD |

680400 to 6804E0(H) - NCU parameters (Refer to section 4.3 for details)

680DC8 to 680DEF(H) - SC codes NOT for automatic service call

If the fax unit receives a copier engine SC code other than those programmed in these addresses, the fax unit sends an automatic service call report to the programmed service station.

Six SC codes have already been programmed at default, as shown in the table below. Fourteen more SC codes can be programmed, if required (if an address contains FF(H), a code is not programmed in it).

Program a SC code in four-digit BCD format as shown in the example below.

Example 1: SC code '192'

Address (High) - 01 (BCD)

Address (Low) - 92 (BCD)

Wildcard characters "a" or "A" can be used to specify a series of SC codes.

Example 2: SC code '900 to 999'

Address (High) – 09 (BCD)

Address (Low) – aa or AA (Hex)

Example 3: SC code '330 to 339'

Address (High) – 03 (BCD)

Address (Low) – 3a or 3A (Hex)

- Default settings -

| High Address (H) | Data (BCD) | Low Address (L) | Data (BCD) | SC code |
|------------------------|------------|------------------------|------------|----------------|
| 680DC8 | 03 | 680DC9 | 29 | 329 |
| 680DCA | 03 | 680DCB | 61 | 361 |
| 680DCC | 03 | 680DCD | 65 | 365 |
| 680DCE | 05 | 680DCF | 48 | 548 |
| 680DD0 | 06 | 680DD1 | 30 | 630 |
| 680DD2 | 09 | 680DD3 | AA | 900 to 999 |
| 680DD4 to 680DEE | FF(H) | 680DD5 to 680DEF | FF(H) | Not Programmed |

68849C to 68889B(H) - Dedicated tx parameters for Quick Dial 01 - 32.

There are 32 bytes for each Quick Dial. Only the 23rd to 32nd bytes are used.

6884B2 to 6884BB(H) - Dedicated tx parameters for Quick 01

6884D2 to 6884DB(H) - Dedicated tx parameters for Quick 02

6884F2 to 6884FB(H) - Dedicated tx parameters for Quick 03



688892 to 68889B(H) - Dedicated tx parameters for Quick 32

688B9C to 68981B(H) - Dedicated tx parameters for Speed Dial #00 - #99.

There are 32 bytes for each Speed Dial. Only the 23rd to 32nd bytes are used.

688BB2 to 688BBB(H) - Dedicated tx parameters for Speed #00

688BD2 to 688BDB(H) - Dedicated tx parameters for Speed #01

688BF2 to 688BFB(H) - Dedicated tx parameters for Speed #02

↓

689812 to 68981B(H) - Dedicated tx parameters for Speed #99

68E8E4 to 68E8E5(H) - Line type change (refer to section 2 for more details)

68E8E4(H) - Current line type setting

68E8E5(H) - Line type to be used after the procedure

69CA00 to 69CBFF(H) - Latest 64 error codes (Read only)

One error record consists of 8 bytes of data.

First error record start address – 69CA00(H)

Second error record start address – 69CA08(H)

Third error record start address – 69CA10(H)

:

64th error record start address – 69CBF8(H)

The format is as follows:

1st byte - Minute (BCD)

2nd byte - Hour (BCD)

3rd byte - Day (BCD)

4th byte - Month (BCD)

5th byte - Error code – low (BCD) [If the error code is 1-23, 23 is stored here.]

6th byte - Error code – high (BCD) [If the error code is 1-23, 01 is stored here.]

7th byte - Communication line (Hex)

PSTN: 00(H), PABX: 02(H), ISDN G3: 0C(H), ISDN G4: 0D(H)

8th byte - Not used

69E134 to 69E813(H) - Latest 20 error communication records (Read only)

One error communication record consists of 88 bytes. The format is as follows:

1st byte - Header

| | |
|--|---------------------------------------|
| Bit 0: Communication result | 0: OK, 1: NG |
| Bit 1: Document jam | 1: Occurred |
| Bit 2: Power down | 1: Occurred |
| Bit 3: Not used | |
| Bit 4: Technical data printout instead of personal codes | 0: No, 1: Yes |
| Bit 5: Type of technical data | 0: Rx level, 1: Measure of error rate |
| Bit 6: Error report | 0: Not printed, 1: Printed |
| Bit 7: Data validity | 0: Not valid, 1: Valid |

2nd byte - Not used

3rd to 6th bytes - Date and time when the communication started

3rd byte - Month (BCD)

4th byte - Day (BCD)

5th byte - Hour (BCD)

6th byte - Minute (BCD)

7th and 8th bytes - Communication time

7th byte - Minutes (BCD)

8th byte - Seconds (BCD)

9th and 10th bytes - Number of pages transmitted or received

9th byte - Low byte (Hex)

10th byte - High byte (Hex)

11th and 12th bytes - Personal code or number of total/burst error lines

If bit 4 of the 1st byte is 0:

11th byte - Personal code (low - BCD)

12th byte - Personal code (high - BCD)

If bit 4 of the 1st byte is 1:

11th byte - Number of total error lines (Hex)

12th byte - Number of burst error lines (Hex)

13th byte - File number (low - Hex)

14th byte - File number (high - Hex)

15th and 16th bytes - Rx level or a measure of the error rate

If bit 5 of the 1st byte is 0:

15th byte - Rx level (low - Hex)

16th byte - Rx level (high - Hex)

If bit 4 of the 1st byte is 1:

15th byte - Measure of error rate (low - Hex)

16th byte - Measure of error rate (high - Hex)

17th byte - Final modem rate

Bits 0 to 3: Final modem speed

$$\begin{pmatrix} \text{Bit0} \\ \text{Bit1} \\ \text{Bit2} \\ \text{Bit3} \end{pmatrix} = \begin{pmatrix} 1 \\ 0 \\ 0 \\ 0 \end{pmatrix} : 2.4 \text{ k} \begin{pmatrix} 0 \\ 1 \\ 0 \\ 0 \end{pmatrix} : 4.8 \text{ k} \begin{pmatrix} 1 \\ 1 \\ 0 \\ 0 \end{pmatrix} : 7.2 \text{ k} \begin{pmatrix} 0 \\ 0 \\ 1 \\ 0 \end{pmatrix} : 9.6 \text{ k} \begin{pmatrix} 1 \\ 0 \\ 1 \\ 0 \end{pmatrix} : 12.0 \text{ k} \begin{pmatrix} 0 \\ 1 \\ 1 \\ 0 \end{pmatrix} : 14.4 \text{ k} \begin{pmatrix} 1 \\ 1 \\ 1 \\ 0 \end{pmatrix} : 16.8 \text{ k}$$

$$\begin{pmatrix} \text{Bit0} \\ \text{Bit1} \\ \text{Bit2} \\ \text{Bit3} \end{pmatrix} = \begin{pmatrix} 0 \\ 0 \\ 0 \\ 1 \end{pmatrix} : 19.2 \text{ k} \begin{pmatrix} 1 \\ 0 \\ 0 \\ 1 \end{pmatrix} : 21.6 \text{ k} \begin{pmatrix} 0 \\ 1 \\ 0 \\ 1 \end{pmatrix} : 24.0 \text{ k} \begin{pmatrix} 1 \\ 1 \\ 0 \\ 1 \end{pmatrix} : 26.4 \text{ k} \begin{pmatrix} 0 \\ 0 \\ 1 \\ 1 \end{pmatrix} : 28.8 \text{ k} \begin{pmatrix} 1 \\ 0 \\ 1 \\ 1 \end{pmatrix} : 31.2 \text{ k} \begin{pmatrix} 0 \\ 1 \\ 1 \\ 1 \end{pmatrix} : 33.6 \text{ k}$$

Bits 4 to 6: Final modem type

$$\begin{pmatrix} \text{Bit4} \\ \text{Bit5} \\ \text{Bit6} \\ \text{Bit7} \end{pmatrix} = \begin{pmatrix} 1 \\ 0 \\ 0 \\ 0 \end{pmatrix} : \text{V.27ter} \begin{pmatrix} 0 \\ 1 \\ 0 \\ 0 \end{pmatrix} : \text{V.29} \begin{pmatrix} 1 \\ 1 \\ 0 \\ 0 \end{pmatrix} : \text{V.33} \begin{pmatrix} 0 \\ 0 \\ 1 \\ 0 \end{pmatrix} : \text{V.17 (Long)} \begin{pmatrix} 1 \\ 0 \\ 1 \\ 0 \end{pmatrix} : \text{V.17 (Short)}$$

$$\begin{pmatrix} \text{Bit4} \\ \text{Bit5} \\ \text{Bit6} \\ \text{Bit7} \end{pmatrix} = \begin{pmatrix} 1 \\ 0 \\ 0 \\ 1 \end{pmatrix} : \text{V.34} \begin{pmatrix} 0 \\ 1 \\ 0 \\ 1 \end{pmatrix} : \text{V.34} \begin{pmatrix} 1 \\ 1 \\ 0 \\ 1 \end{pmatrix} : \text{V.34} \begin{pmatrix} 0 \\ 0 \\ 1 \\ 1 \end{pmatrix} : \text{V.34} \begin{pmatrix} 1 \\ 0 \\ 1 \\ 1 \end{pmatrix} : 2400 \text{ baud} \begin{pmatrix} 0 \\ 0 \\ 1 \\ 1 \end{pmatrix} : 3000 \text{ baud} \begin{pmatrix} 1 \\ 0 \\ 1 \\ 1 \end{pmatrix} : 3200 \text{ baud} \begin{pmatrix} 0 \\ 0 \\ 1 \\ 1 \end{pmatrix} : 2800 \text{ baud} \begin{pmatrix} 1 \\ 0 \\ 1 \\ 1 \end{pmatrix} : 3429 \text{ baud}$$

18th to 20th byte - Not used

21st to 44th byte - Remote terminal's ID (RTI, TSI or CSI) (ASCII)

45th byte - Communication mode #1

Bits 0 - 1: Network

$$\begin{pmatrix} \text{Bit0} \\ \text{Bit1} \end{pmatrix} = \begin{pmatrix} 1 \\ 0 \end{pmatrix} : \text{PSTN} \begin{pmatrix} 0 \\ 1 \end{pmatrix} : \text{ISDN}$$

Bit 2: Communication protocol 0: G3, 1: G4

Bit 3: ECM 0: Off, 1: On

Bits 4 to 7: Communication mode used

$$\begin{pmatrix} \text{Bit4} \\ \text{Bit5} \\ \text{Bit6} \\ \text{Bit7} \end{pmatrix} = \begin{pmatrix} 0 \\ 0 \\ 0 \\ 0 \end{pmatrix} : \text{Normal} \begin{pmatrix} 1 \\ 0 \\ 0 \\ 0 \end{pmatrix} : \text{Confidential} \begin{pmatrix} 0 \\ 1 \\ 0 \\ 0 \end{pmatrix} : \text{Polling} \begin{pmatrix} 1 \\ 1 \\ 0 \\ 0 \end{pmatrix} : \text{Transfer}$$

$$\begin{pmatrix} \text{Bit4} \\ \text{Bit5} \\ \text{Bit6} \\ \text{Bit7} \end{pmatrix} = \begin{pmatrix} 0 \\ 0 \\ 1 \\ 0 \end{pmatrix} : \text{Forwarding} \begin{pmatrix} 1 \\ 0 \\ 1 \\ 0 \end{pmatrix} : \text{Automatic Service Call}$$

Service Tables

46th byte - Communication mode #2

| | |
|--------------------------------|----------------------------|
| Bit 0: Tx or Rx | 0: Tx, 1: Rx |
| Bit 1: Reduction during Tx | 0: Not reduced, 1: Reduced |
| Bit 2: Batch transmission | 0: Not used, 1: Used |
| Bit 3: Send later transmission | 0: Not used, 1: Used |
| Bit 4: Transmission from | 0: ADF, 1: Memory |
| Bits 5 to 7: Not used | |

47th byte - Not used

48th byte - Number of errors during communication (Hex)

49th to 52nd byte - 1st error code and page number where the error occurred

49th byte - Page number where the error occurred (low - Hex)

50th byte - Page number where the error occurred (high - Hex)

51st byte - Error code (low - BCD)

52nd byte - Error code (high - BCD)

53rd to 56th byte - 2nd error code and page number where the error occurred

57th to 60th byte - 3rd error code and page number where the error occurred

61st to 64th byte - 4th error code and page number where the error occurred

65th to 68th byte - 5th error code and page number where the error occurred

69th to 72nd byte - 6th error code and page number where the error occurred

73rd to 76th byte - 7th error code and page number where the error occurred

77th to 80th byte - 8th error code and page number where the error occurred

81st to 84th byte - 9th error code and page number where the error occurred

85th to 88th byte - 10th error code and page number where the error occurred

7644F0 to 76B56F(H) - Dedicated tx parameters for Speed Dial #100 - #999, when the optional EXFUNC board is installed.

There are 32 bytes for each Speed Dial. Only the 23rd to 32nd bytes are used.

764506 to 76450F(H) - Dedicated tx parameters for Speed #100

764526 to 76452F(H) - Dedicated tx parameters for Speed #101

764546 to 76454F(H) - Dedicated tx parameters for Speed #102

↓

76B566 to 76B56F(H) - Dedicated tx parameters for Speed #999

5. PREVENTIVE MAINTENANCE

5.1 SPECIAL TOOLS AND LUBRICANTS

- Flash/SRAM data copy tool (P/N: A1939353)
- Flash Memory Card – 4MB (P/N: A2309352)
- Card Case (P/N: A2309351)

5.2 PM TABLE

No PM necessary for the fax option.

6. REMOVAL AND REPLACEMENT

6.1 PRECAUTION

⚠ CAUTION

Before starting disassembly, be sure to print all message files in the SAF memory. Then, turn off the main power switch and disconnect the power cord and telephone cable for safety.

Lithium Battery

The danger of explosion exists if a battery of this type is incorrectly replaced. Replace only with the same or an equivalent type recommended by the manufacturer. Discard used batteries in accordance with the manufacturer's instructions.

6.2 NCU AND SPEAKER

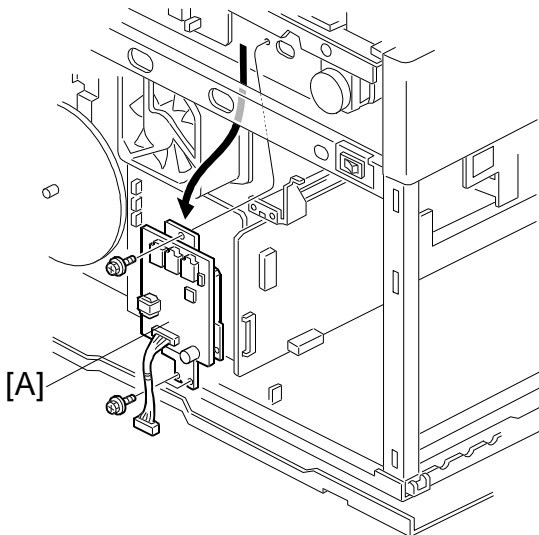

A891R504.WMF

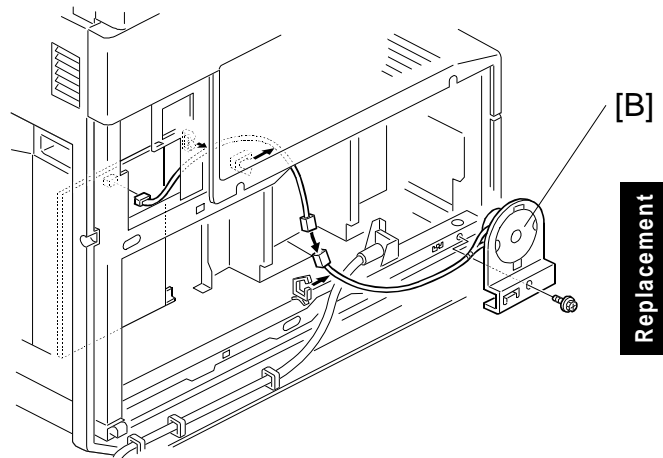

A891R501.WMF

Replacement
Adjustment

1. NCU: Remove the rear cover.
Speaker: Remove the left side cover.
2. Remove the NCU/speaker assembly [A/B].
3. Remove the NCU/speaker from the assembly.

6.3 FCU

6.3.1 REMOVAL

Note: If the machine has an optional printer controller installed, remove it before starting the following procedure.

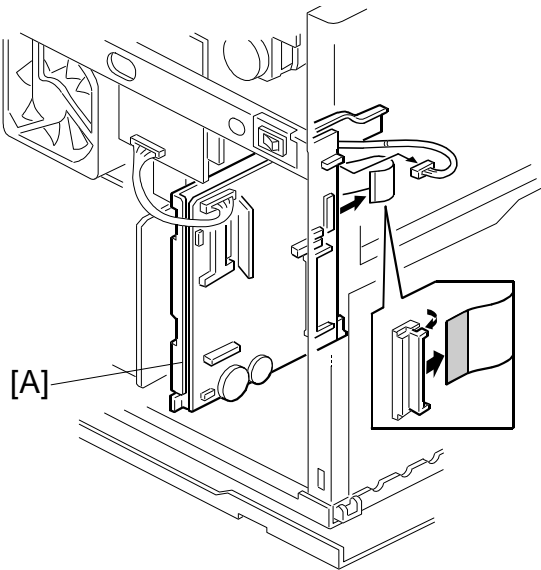

A891R502.WMF

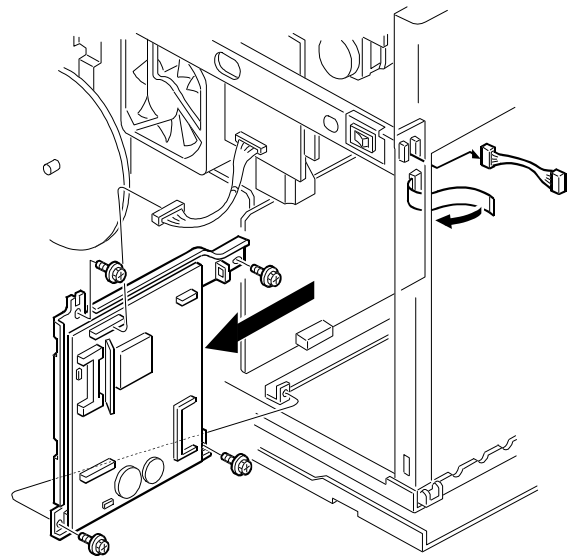

A891R503.WMF

1. Remove the rear cover and the left side cover.
2. Remove the FCU bracket [A] (4 screws), then the FCU. (6 screws, 4 connectors)
Turn on SW3 and turn off SW1 on the new FCU.
NOTE: Do not turn off SW3 on the old FCU if you will use it to restore SRAM data to the new FCU.
3. Go to one of the following procedures:
 - To restore SRAM data from the old FCU (if you do not have the latest data backup) – Go to section 6.3.2.
 - To restore SRAM data from a flash memory card backup – Go to section 6.3.3.

6.3.2 SRAM DATA RESTORE FROM FCU

Before restoring the SRAM data, install a new FCU and initialize the SRAM on the new FCU using the following procedure.

1. Install a new FCU in the machine (see section 6.3.1)
Do not put back the EXFUNC and EXMEM boards yet, if they were present.
2. Turn on the machine. The machine displays “SC1201”.
NOTE: The machine always displays “SC1201” the first time a new FCU with no RAM data is installed. Please ignore it.
3. Press YES to initialize the SRAM.

Then, restore the SRAM using the following procedure.

4. Turn off the machine.
5. Connect the data copy tool [A] with the old FCU [B] to the card slot as shown. See the note below for the switch settings.

IMPORTANT: Support the old FCU by hand from now until the end of the download procedure

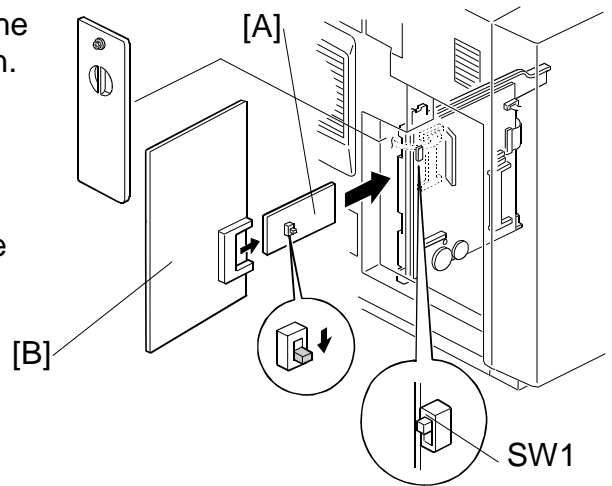

A891R507.WMF

- NOTE:**
- 1) The switch on the data copy tool must be OFF.
 - 2) SW1 below the card slot must be OFF.
 - 3) Do not turn off the battery switch on the old FCU.

6. Turn on the machine, and enter the fax service mode.
7. Press then .

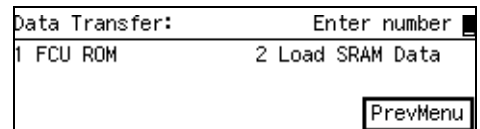

A891R510.TIF

8. Press .

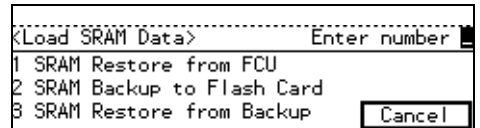

A891R511.TIF

If the switch settings are correct, the message on the right appears. Then go to the next step.

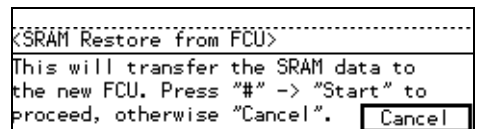

A891R512.TIF

If one of the switch settings is wrong, or if the tool is not connected correctly, the message on the right appears. Then turn off the machine and retry the procedure.

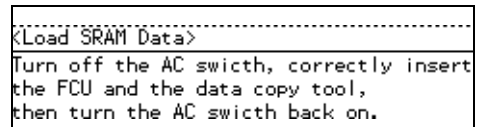

A891R513.TIF

9. Press "#" then .
- If data has been restored successfully, the message on the right appears.

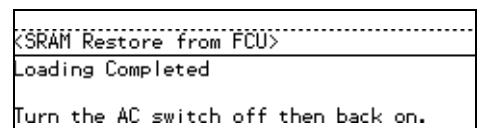

A891R514.TIF

Replacement Adjustment

10. Turn off the main power switch then disconnect the tools.
11. Install the EXFUNC and EXMEM boards if they were present.
12. Turn the machine back on.
13. Print the system parameter list to check if the previous settings have been successfully recovered.

6.3.3 SRAM DATA RESTORE FROM FLASH CARD BACKUP

SRAM data can be copied to a flash memory card. For how to do this, refer to section 6.5.

Before restoring the SRAM data, install a new FCU and initialize the SRAM on the new FCU using the following procedure.

1. Install a new FCU in the machine (see section 6.3.1).
2. Turn on the machine. The machine displays "SC1201".
NOTE: The machine always displays "SC1201" the first time the FCU is installed. Please ignore it.
3. Press YES to initialize the SRAM.

Then, restore the SRAM using the following procedure.

4. Turn off the machine.
NOTE: If the EXFUNC board was present; make sure that a backup of both the EXFUNC and FCU SRAM data is available, then install the EXFUNC.
If the EXFUNC backup is not available, restore the data from the old FCU before installing the EXFUNC board on the new FCU.

5. Connect the flash memory card [A] to the card slot as shown.
See the note below for the switch settings.

NOTE: 1) SW1 below the card slot must be OFF.
2) If the switch setting is wrong, the fax function will not start up.

6. Turn on the machine, and enter the fax service mode.

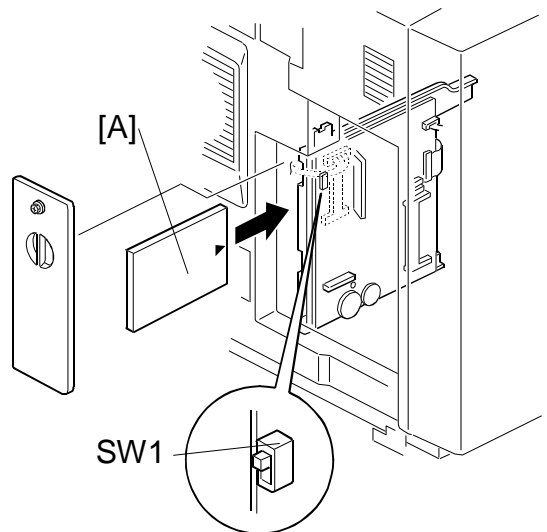

A891R506.WMF

7. Press **1** **6** then **2**.

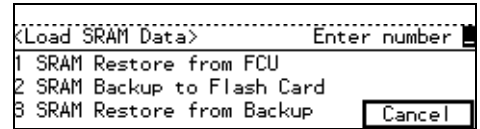

A891R511.TIF

8. Press **3**.

If the switch settings are correct, either of the messages below appears.



A891R515.TIF

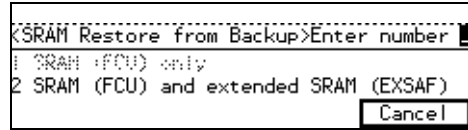

A891R516.TIF

Refer to the table below for which type of backup must be used, depending on the presence of an EXFUNC board.

| EXFUNC board | Type of backup | |
|--------------|----------------|---------------------|
| | FCU SRAM | FCU and EXFUNC SRAM |
| Not present | OK | Do not use. |
| Present | Do not use. | OK |

9. Press either of the following:

1 – Standard SRAM only

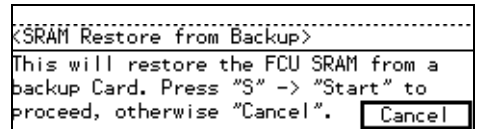

A891R517.TIF

2 – Standard SRAM and SRAM on the EXFUNC.

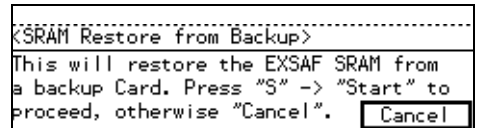

A693R518.TIF

10. Press "S" then **⏏**; a confirmation message appears.

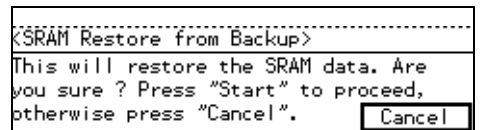

A891R519.TIF

11. Press Start to restore the SRAM.

If data has been restored successfully, the message on the right appears.

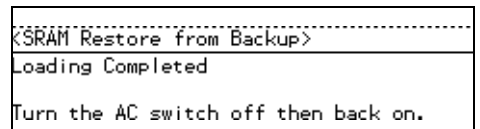

A891R520.TIF

12. Turn off the main power switch then disconnect the card.

13. Turn the machine back on.

- Print the system parameter list to check if the previous settings have been successfully recovered.

6.4 FIRMWARE UPDATE

6.4.1 FCU FIRMWARE DOWNLOAD

This function updates the FCU firmware using a flash memory card.

- Turn off the machine and remove the cover [A].

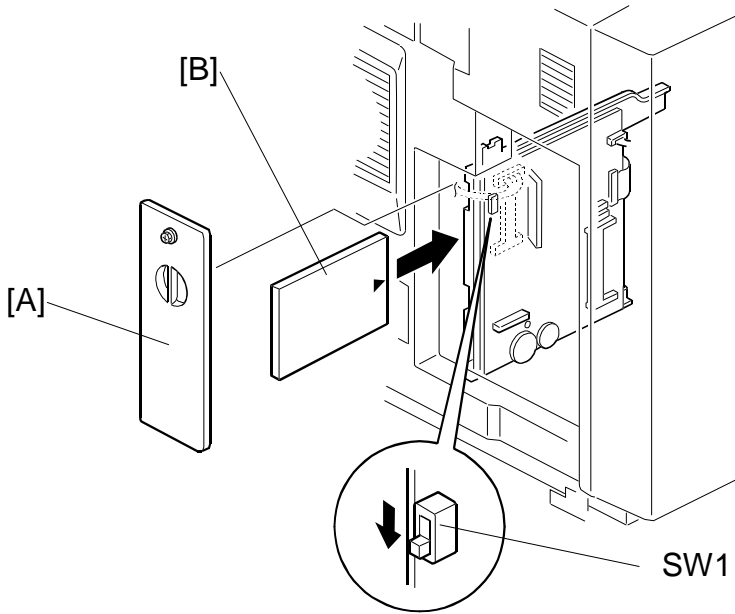

A891R505.WMF

- Connect the flash memory card [B] to the card slot as shown.

NOTE: SW1 below the card slot must be **ON**.

- Turn on the machine and enter the fax service mode.
- Press **1** **6** then **1**.

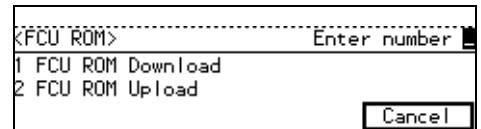

A891R521.TIF

- Press **1**.
If the switch setting is correct, the message on the right appears.
Then go to the next step.

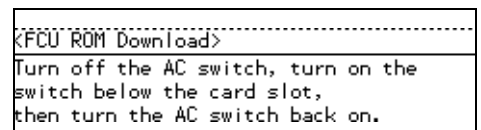

A891R522.TIF

If the switch setting is wrong, or if the tool is not connected correctly, the message on the right appears. Then turn off the machine and retry the procedure again.

6. Press OK, then check the ROM version. If the card does not contain FCU ROM data, "Please check flash card" appears. Turn off the machine and retry the procedure with the correct card.
7. Press Start.

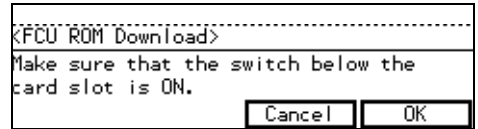

A891R522.TIF

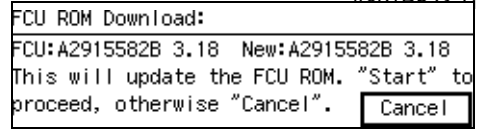

A891R519.TIF

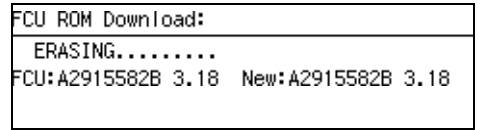

A891R525.TIF

After the machine updates the ROM data, the message on the right appears.

8. Turn off the main power switch then disconnect the flash memory card.
9. Turn the machine back on.
10. Print the system parameter list to check if the new ROM version is printed.

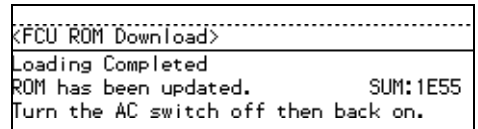

A891R526.TIF



6.4.2 FCU ROM UPLOAD

This function makes a copy of the FCU ROM inside the machine onto a flash memory card.

NOTE: This procedure erases the flash memory card completely before uploading ROM data.

1. Turn off the machine and remove the cover [A].

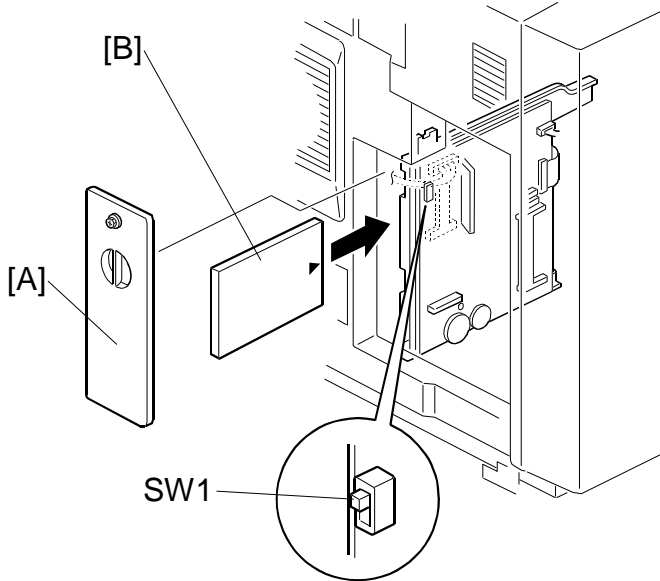

A8913R506.WMF

2. Connect the flash memory card [B] to the card slot as shown.

NOTE: SW1 below the card slot must be **OFF**.

3. Turn on the machine and enter the fax service mode.
4. Press **1** **6** then **1**.

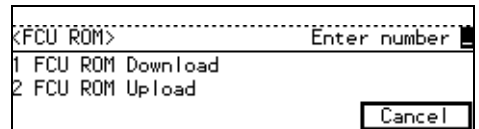

A891R521.TIF

5. Press **2**.
If the switch setting is correct, the message on the right appears.
Then go to the next step.

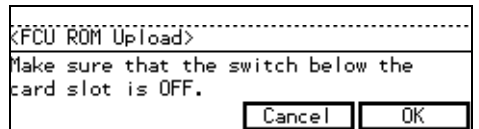

A891R527.TIF

If the switch setting is wrong, or if the tool is not connected correctly, the message on the right appears. Then turn off the machine and retry the procedure.

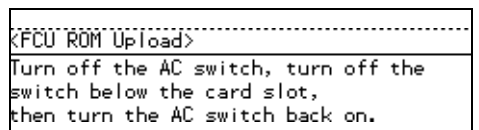

A891R528.TIF

6. Press OK, then check the ROM version.

```
FCU ROM Upload:
FCU:A2915582B 3.18 Flash Card
This will upload the FCU ROM. "Start" to
proceed, otherwise "Cancel". 
```

A891R523.TIF

7. Press Start.

```
FCU ROM Upload:
ERASING.....
FCU:A2915582B 3.18 Flash Card
```

A891R524.TIF

After the machine updates the ROM data, the message on the right appears.

```
FCU ROM Upload:
Loading Completed
FCU:A2915582B 3.18 Flash Card SUM:F17C
Turn the AC switch off then back on.
```

A891R525.TIF

8. Turn off the main power switch then disconnect the flash memory card.
9. Turn the machine back on.

6.5 SRAM DATA BACKUP AND RESTORE

6.5.1 SRAM BACKUP TO A FLASH MEMORY CARD

This function makes a backup copy of all the fax SRAM data onto a flash memory card. If a computer-based PC card writer system is available, the backup can be saved as a computer file from the flash memory card.

If the EXFUNC board is not installed, this function makes a backup copy of the standard SRAM on the FCU.

If the EXFUNC board is installed, this function makes a backup copy of the standard SRAM and the SRAM on the optional EXFUNC board.

NOTE: This procedure erases the flash memory card completely before uploading SRAM data.

1. Turn off the machine and remove the cover [A].

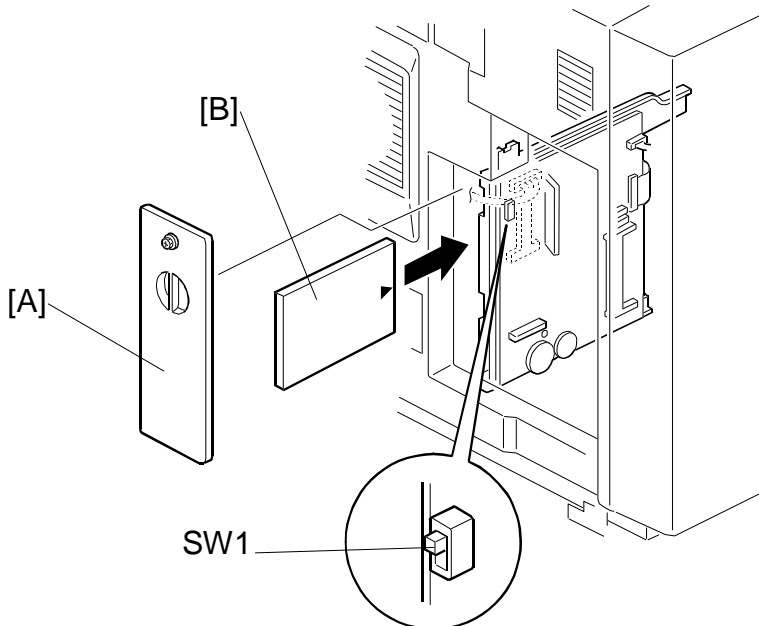

A891R506.WMF

2. Connect the flash memory card [B] to the card slot as shown.

NOTE: SW1 below the card slot must be **OFF**.

3. Turn on the machine and enter the fax service mode.

4. Press then .

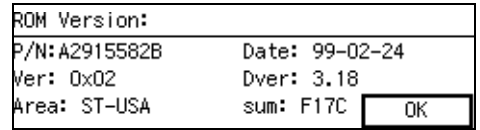

A891R511.TIF

5. Press .

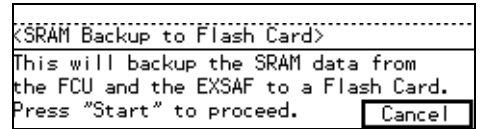

A891R536.TIF

6. Press Start.

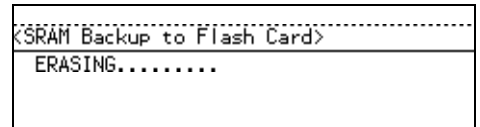

A891R537.TIF

After the machine backs up the data to the flash card, the message on the right appears.

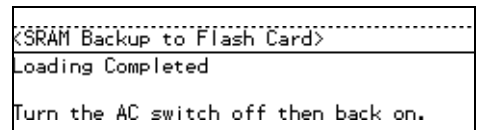

A891R538.TIF

7. Turn off the main power switch then disconnect the flash memory card.
8. Turn the machine back on

The data in the flash card can be copied to a PC for safe keeping. This data can then be uploaded from the PC to a flash memory card if the SRAM data has to be restored later.

Refer to the SwapFTL manual for details about how to copy files from flash card to PC and vice versa.

6.5.2 SRAM RESTORE FROM A FLASH MEMORY CARD

This function recovers SRAM data if the FCU is replaced or SRAM data was lost accidentally.

For how to restore the SRAM data from the backup on a flash memory card, refer to section 6.3.3.

7. TROUBLESHOOTING

7.1 ERROR CODES

If an error code occurs, retry the communication. If the same problem occurs, try to fix the problem as suggested below. Note that some error codes appear only in the error code display and on the service report.

| Code | Meaning | Suggested Cause/Action |
|------|---|---|
| 0-00 | DIS/NSF not detected within 40 s of Start being pressed | <ul style="list-style-type: none"> • Check the line connection. • Check the NCU - FCU connectors. • The machine at the other end may be incompatible. • Replace the NCU or FCU. • Check for DIS/NSF with an oscilloscope. • If the rx signal is weak, there may be a bad line. |
| 0-01 | DCN received unexpectedly | <ul style="list-style-type: none"> • The other party is out of paper or has a jammed printer. • The other party pressed Stop during communication. |
| 0-03 | Incompatible modem at the other end | <ul style="list-style-type: none"> • The other terminal is incompatible. |
| 0-04 | CFR or FTT not received after modem training | <ul style="list-style-type: none"> • Check the line connection. • Check the NCU - FCU connectors. • Try changing the tx level and/or cable equalizer settings. • Replace the FCU or NCU. • The other terminal may be faulty; try sending to another machine. • If the rx signal is weak or defective, there may be a bad line. <p>Cross reference</p> <ul style="list-style-type: none"> • Tx level - NCU Parameter 01 (PSTN) • Cable equalizer - G3 Switch 07 (PSTN) • Dedicated Tx parameters - Section 4 |
| 0-05 | Unsuccessful after modem training at 2400 bps | <ul style="list-style-type: none"> • Check the line connection. • Check the NCU - FCU connectors. • Try adjusting the tx level and/or cable equalizer. • Replace the FCU or NCU. • Check for line problems. <p>Cross reference</p> <ul style="list-style-type: none"> • See error code 0-04. |

| Code | Meaning | Suggested Cause/Action |
|------|--|--|
| 0-06 | The other terminal did not reply to DCS | <ul style="list-style-type: none"> • Check the line connection. • Check the FCU - NCU connectors. • Try adjusting the tx level and/or cable equalizer settings. • Replace the NCU or FCU. • The other end may be defective or incompatible; try sending to another machine. • Check for line problems. <p>Cross reference</p> <ul style="list-style-type: none"> • See error code 0-04. |
| 0-07 | No post-message response from the other end after a page was sent | <ul style="list-style-type: none"> • Check the line connection. • Check the FCU - NCU connectors. • Replace the NCU or FCU. • The other end may have jammed or run out of paper. • The other end user may have disconnected the call. • Check for a bad line. • The other end may be defective; try sending to another machine. |
| 0-08 | The other end sent RTN or PIN after receiving a page, because there were too many errors | <ul style="list-style-type: none"> • Check the line connection. • Check the FCU - NCU connectors. • Replace the NCU or FCU. • The other end may have jammed, or run out of paper or memory space. • Try adjusting the tx level and/or cable equalizer settings. • The other end may have a defective modem/NCU/FCU; try sending to another machine. • Check for line problems and noise. <p>Cross reference</p> <ul style="list-style-type: none"> • Tx level - NCU Parameter 01 (PSTN) • Cable equalizer - G3 Switch 07 (PSTN) • Dedicated Tx parameters - Section 4 |
| 0-14 | Non-standard post message response code received | <ul style="list-style-type: none"> • Check the FCU - NCU connectors. • Incompatible or defective remote terminal; try sending to another machine. • Noisy line: resend. • Try adjusting the tx level and/or cable equalizer settings. • Replace the NCU or FCU. <p>Cross reference</p> <ul style="list-style-type: none"> • See error code 0-08. |

| Code | Meaning | Suggested Cause/Action |
|------|--|---|
| 0-15 | The other terminal is not capable of specific functions. | <p>The other terminal is not capable of accepting the following functions, or the other terminal's memory is full.</p> <ul style="list-style-type: none"> • Confidential rx • Transfer function • SEP/SUB/PWD/SID |
| 0-16 | CFR or FTT not detected after modem training in confidential or transfer mode | <ul style="list-style-type: none"> • Check the line connection. • Check the FCU - NCU connectors. • Replace the NCU or FCU. • Try adjusting the tx level and/or cable equalizer settings. • The other end may have disconnected, or it may be defective; try calling another machine. • If the rx signal level is too low, there may be a line problem. <p>Cross reference</p> <ul style="list-style-type: none"> • See error code 0-08. |
| 0-17 | Communication was interrupted by pressing the Stop key. | <p>If the Stop key was not pressed and this error keeps occurring, replace the operation panel.</p> |
| 0-20 | Facsimile data not received within 6 s of retraining | <ul style="list-style-type: none"> • Check the line connection. • Check the FCU - NCU connectors. • Replace the NCU or FCU. • Check for line problems. • Try calling another fax machine. • Try adjusting the reconstruction time for the first line and/or rx cable equalizer setting. <p>Cross reference</p> <ul style="list-style-type: none"> • Reconstruction time - G3 Switch 0A, bit 6 • Rx cable equalizer - G3 Switch 07 (PSTN) |
| 0-21 | EOL signal (end-of-line) from the other end not received within 5 s of the previous EOL signal | <ul style="list-style-type: none"> • Check the connections between the FCU, NCU, & line. • Check for line noise or other line problems. • Replace the NCU or FCU. • The remote machine may be defective or may have disconnected. <p>Cross reference</p> <ul style="list-style-type: none"> • Maximum interval between EOLs and between ECM frames - G3 Bit Switch 0A, bit 4 |

| Code | Meaning | Suggested Cause/Action |
|------|--|--|
| 0-22 | The signal from the other end was interrupted for more than the acceptable modem carrier drop time (default: 200 ms) | <ul style="list-style-type: none"> • Check the line connection. • Check the FCU - NCU connectors. • Replace the NCU or FCU. • Defective remote terminal. • Check for line noise or other line problems. • Try adjusting the acceptable modem carrier drop time. <p>Cross reference</p> <ul style="list-style-type: none"> • Acceptable modem carrier drop time - G3 Switch 0A, bits 0 and 1 |
| 0-23 | Too many errors during reception | <ul style="list-style-type: none"> • Check the line connection. • Check the FCU - NCU connectors. • Replace the NCU or FCU. • Defective remote terminal. • Check for line noise or other line problems. • Try asking the other end to adjust their tx level. • Try adjusting the rx cable equalizer setting and/or rx error criteria. <p>Cross reference</p> <ul style="list-style-type: none"> • Rx cable equalizer - G3 Switch 07 (PSTN) • Rx error criteria - Communication Switch 02, bits 0 and 1 |
| 0-30 | The other terminal did not reply to NSS(A) in AI short protocol mode | <ul style="list-style-type: none"> • Check the line connection. • Check the FCU - NCU connectors. • Try adjusting the tx level and/or cable equalizer settings. • The other terminal may not be compatible. <p>Cross reference</p> <ul style="list-style-type: none"> • Dedicated tx parameters - Section 4 |
| 0-32 | The other terminal sent a DCS, which contained functions that the receiving machine cannot handle. | <ul style="list-style-type: none"> • Check the protocol dump list. • Ask the other party to contact the manufacturer. |
| 0-52 | Polarity changed during communication | <ul style="list-style-type: none"> • Check the line connection. • Retry communication. |
| 0-70 | The communication mode specified in CM/JM was not available (V.8 calling and called terminal) | <ul style="list-style-type: none"> • The other terminal did not have a compatible communication mode (e.g., the other terminal was a V.34 data modem and not a fax modem.) • A polling tx file was not ready at the other terminal when polling rx was initiated from the calling terminal. |
| 0-74 | The calling terminal fell back to T.30 mode, because it could not detect ANSam after sending CI. | <ul style="list-style-type: none"> • The calling terminal could not detect ANSam due to noise, etc. • ANSam was too short to detect. • Check the line connection and condition. • Try making a call to another V.8/V.34 fax. |

| Code | Meaning | Suggested Cause/Action |
|-------------|--|--|
| 0-75 | The called terminal fell back to T.30 mode, because it could not detect a CM in response to ANSam (ANSam timeout). | <ul style="list-style-type: none"> • The terminal could not detect ANSam. • Check the line connection and condition. • Try receiving a call from another V.8/V.34 fax. |
| 0-76 | The calling terminal fell back to T.30 mode, because it could not detect a JM in response to a CM (CM timeout). | <ul style="list-style-type: none"> • The called terminal could not detect a CM due to noise, etc. • Check the line connection and condition. • Try making a call to another V.8/V.34 fax. |
| 0-77 | The called terminal fell back to T.30 mode, because it could not detect a CJ in response to JM (JM timeout). | <ul style="list-style-type: none"> • The calling terminal could not detect a JM due to noise, etc. • A network that has narrow bandwidth cannot pass JM to the other end. • Check the line connection and condition. • Try receiving a call from another V.8/V.34 fax. |
| 0-79 | The called terminal detected CI while waiting for a V.21 signal. | Check for line noise or other line problems. If this error occurs, the called terminal falls back to T.30 mode. |
| 0-80 | The line was disconnected due to a timeout in V.34 phase 2 – line probing. | <ul style="list-style-type: none"> • The guard timer expired while starting these phases. Serious noise, narrow bandwidth, or low signal level can cause these errors. |
| 0-81 | The line was disconnected due to a timeout in V.34 phase 3 – equalizer training. | <p>If these errors happen at the transmitting terminal:</p> <ul style="list-style-type: none"> • Try making a call at a later time. • Try using V.17 or a slower modem using dedicated tx parameters. |
| 0-82 | The line was disconnected due to a timeout in the V.34 phase 4 – control channel start-up. | <ul style="list-style-type: none"> • Try increasing the tx level. • Try adjusting the tx cable equalizer setting. <p>If these errors happen at the receiving terminal:</p> |
| 0-83 | The line was disconnected due to a timeout in the V.34 control channel restart sequence. | <ul style="list-style-type: none"> • Try adjusting the rx cable equalizer setting. • Try increasing the tx level. • Try using V.17 or a slower modem if the same error is frequent when receiving from multiple senders. |
| 0-84 | The line was disconnected due to abnormal signaling in V.34 phase 4 – control channel start-up. | <ul style="list-style-type: none"> • The signal did not stop within 10 s. • Turn off the machine, then turn it back on. • If the same error is frequent, replace the FCU. |
| 0-85 | The line was disconnected due to abnormal signaling in V.34 control channel restart. | <ul style="list-style-type: none"> • The signal did not stop within 10 s. • Turn off the machine, then turn it back on. • If the same error is frequent, replace the FCU. |
| 0-86 | The line was disconnected because the other terminal requested a data rate using MPh that was not available in the currently selected symbol rate. | <ul style="list-style-type: none"> • The other terminal was incompatible. • Ask the other party to contact the manufacturer. |

| Code | Meaning | Suggested Cause/Action |
|-------------|---|---|
| 0-87 | The control channel started after an unsuccessful primary channel. | <ul style="list-style-type: none"> The receiving terminal restarted the control channel because data reception in the primary channel was not successful. This does not result in an error communication. |
| 0-88 | The line was disconnected because PPR was transmitted/received 9 (default) times within the same ECM frame. | <ul style="list-style-type: none"> Try using a lower data rate at the start. Try adjusting the cable equalizer setting. |
| 2-10 | The modem cannot enter tx mode | <ul style="list-style-type: none"> Replace the FCU. |
| 2-11 | Only one V.21 connection flag was received | <ul style="list-style-type: none"> Replace the FCU. |
| 2-12 | Modem clock irregularity | <ul style="list-style-type: none"> Replace the FCU. |
| 2-13 | Modem initialization error | <ul style="list-style-type: none"> Turn off the machine, then turn it back on. Update the modem ROM. Replace the FCU. |
| 2-20 | Abnormal coding/decoding (cpu not ready) | <ul style="list-style-type: none"> Replace the FCU. |
| 2-23 | JBIG compression or reconstruction error | <ul style="list-style-type: none"> Turn off the machine, then turn it back on. Replace the EXFUNC board if the error is frequent. |
| 2-24 | JBIG ASIC error | <ul style="list-style-type: none"> Turn off the machine, then turn it back on. Replace the EXFUNC board if the error is frequent. |
| 2-25 | JBIG data reconstruction error (BIH error) | <ul style="list-style-type: none"> JBIG data error Check the sender's JBIG function. Update the FCU ROM. |
| 2-26 | JBIG data reconstruction error (Float marker error) | |
| 2-27 | JBIG data reconstruction error (End marker error) | |
| 2-28 | JBIG data reconstruction error (Timeout) | |
| 2-50 | The machine resets itself for a fatal FCU system error | <ul style="list-style-type: none"> If this is frequent, update the ROM, or replace the FCU. |
| 2-51 | The machine resets itself because of a fatal communication error | <ul style="list-style-type: none"> If this is frequent, update the ROM, or replace the FCU. |
| 3-00 | G4 interface board reset | <ul style="list-style-type: none"> Replace the G4 interface board or FCU. |
| 3-10 | Disconnection during ISDN G3 communication | <ul style="list-style-type: none"> Check the other terminal and the ISDN line. The other terminal may have dialed a wrong number. |
| 3-11 | Disconnection during ISDN G4 communication | <ul style="list-style-type: none"> Check the other terminal and the ISDN line. |
| 3-20 | A CSA signal was received during ISDN G4 communication | <ul style="list-style-type: none"> The operator at the other terminal may have interrupted the communication. |

| Code | Meaning | Suggested Cause/Action |
|-------------|--|---|
| 3-21 | A CSA signal was sent during ISDN G4 communication, because the Stop key was pressed | <ul style="list-style-type: none"> The local operator has interrupted the communication. |
| 3-30 | Mismatched specifications (rx capability) | <ul style="list-style-type: none"> Check the receive capabilities requested from the other terminal. |
| 4-01 | Line current was cut | <ul style="list-style-type: none"> Check the line connector. Check the connection between FCU and NCU. Check for line problems. Replace the FCU or the NCU. |
| 4-10 | Communication failed because of an ID Code mismatch (Closed Network) or Tel. No./CSI mismatch (Protection against Wrong Connections) | <ul style="list-style-type: none"> Get the ID Codes the same and/or the CSIs programmed correctly, then resend. The machine at the other end may be defective. |
| 5-00 | Data construction not possible | <ul style="list-style-type: none"> Replace the FCU. |
| 5-01 | Data reconstruction not possible | |
| 5-10 | DCR timer expired | |
| 5-20 | Storage impossible because of a lack of memory | <ul style="list-style-type: none"> Temporary memory shortage. Test the SAF memory. Replace the FCU or optional EXMEM board |
| 5-21 | Memory overflow | |
| 5-22 | Mode table overflow after the second page of a scanned document | <ul style="list-style-type: none"> Wait for the messages which are currently in the memory to be sent or delete some files from memory. |
| 5-23 | Print data error when printing a substitute rx or confidential rx message | <ul style="list-style-type: none"> Test the SAF memory. Ask the other end to resend the message. Replace the FCU or optional EXMEM board. |
| 5-24 | Memory overflow after the second page of a scanned document | <ul style="list-style-type: none"> Try using a lower resolution setting. Wait for the messages which are currently in the memory to be sent or delete some files from memory. |
| 5-25 | SAF file access error | <ul style="list-style-type: none"> Replace the FCU or EXMEM board. |
| 6-00 | G3 ECM - T1 time out during reception of facsimile data | <ul style="list-style-type: none"> Try adjusting the rx cable equalizer. Replace the FCU or NCU. |
| 6-01 | G3 ECM - no V.21 signal was received | |
| 6-02 | G3 ECM - EOR was received | |

| Code | Meaning | Suggested Cause/Action |
|------|--|--|
| 6-04 | G3 ECM - RTC not detected | <ul style="list-style-type: none"> • Check the line connection. • Check connections from the NCU to the FCU. • Check for a bad line or defective remote terminal. • Replace the FCU or NCU. |
| 6-05 | G3 ECM - facsimile data frame not received within 18 s of CFR, but there was no line fail | <ul style="list-style-type: none"> • Check the line connection. • Check connections from the NCU to the FCU. • Check for a bad line or defective remote terminal. • Replace the FCU or NCU. • Try adjusting the rx cable equalizer <p>Cross reference</p> <ul style="list-style-type: none"> • Rx cable equalizer - G3 Switch 07 (PSTN) |
| 6-06 | G3 ECM - coding/decoding error | <ul style="list-style-type: none"> • Defective FCU. • The other terminal may be defective. |
| 6-08 | G3 ECM - PIP/PIN received in reply to PPS.NULL | <ul style="list-style-type: none"> • The other end pressed Stop during communication. • The other terminal may be defective. |
| 6-09 | G3 ECM - ERR received | <ul style="list-style-type: none"> • Check for a noisy line. • Adjust the tx levels of the communicating machines. • See code 6-05. |
| 6-10 | G3 ECM - error frames still received at the other end after all communication attempts at 2400 bps | <ul style="list-style-type: none"> • Check for line noise. • Adjust the tx level (use NCU parameter 01 or the dedicated tx parameter for that address). • Check the line connection. • Defective remote terminal. |
| 6-21 | V.21 flag detected during high speed modem communication | <ul style="list-style-type: none"> • The other terminal may be defective or incompatible. |
| 6-22 | The machine resets the sequence because of an abnormal handshake in the V.34 control channel | <ul style="list-style-type: none"> • Check for line noise. • If the same error occurs frequently, replace the FCU. • Defective remote terminal. |
| 6-99 | V.21 signal not stopped within 6 s | <ul style="list-style-type: none"> • Replace the FCU. |

| Code | Meaning | Suggested Cause/Action |
|-------------|--|---|
| 9-40 | CRC error during PC fax communication | <ul style="list-style-type: none"> • Check the serial interface and cable connection between the PC. • Replace the DIU (PCFE board) or FCU. |
| 9-41 | Third failure during PC fax communication | |
| 9-42 | DCN received unexpectedly during PC fax communication | |
| 9-43 | Frame received unexpectedly during PC fax communication | |
| 9-44 | Response time over during PC fax communication | |
| 9-45 | Frame transmission error during PC fax communication | |
| 9-61 | Memory overflow occurs during reception | Check the SAF. |
| 22-00 | Original length exceeded the maximum scan length | <ul style="list-style-type: none"> • Divide the original into a few pages. • Check the resolution used for scanning. Lower the scan resolution if possible. • Add optional page memory. |
| 22-01 | Memory overflow while receiving | <ul style="list-style-type: none"> • Wait for the files in the queue to be sent. • Delete unnecessary files from memory. • Transfer the substitute reception files to an another fax machine, if the machine's printer is busy or out of order. • Add an optional SAF memory card or hard disk. |
| 22-02 | Tx or rx job stalled due to line disconnection at the other end | <ul style="list-style-type: none"> • The job started normally but did not finish normally; data may or may not have been received fully. • Restart the machine. |
| 22-04 | The machine cannot store received data in the SAF | <ul style="list-style-type: none"> • Update the ROM • Replace the FCU. |
| 23-00 | Data read timeout during construction | <ul style="list-style-type: none"> • Restart the machine. • Replace the FCU |
| 25-00 | The machine software resets itself after a fatal transmission error occurred | <ul style="list-style-type: none"> • Update the ROM • Replace the FCU. |
| F0-xx | V.34 modem error | <ul style="list-style-type: none"> • Replace the FCU. |

7.2 FAX SC CODES

7.2.1 OVERVIEW

When the FCU detects a Fax SC Code condition other than SC1201 and SC1207, it resets itself automatically (default setting). This initializes the FCU without erasing files in the SAF memory or resetting the switches.

NOTE: For details on Fax SC Codes 1201 and 1207, refer to the following sections.

If bit 7 of System Switch 1F is changed to “1”, when the FCU detects a Fax SC Code condition, it displays the code on the display and stops working until the fax unit is initialized using one of the following methods:

- Hold down the “#” and “*” keys for more than 10 s.
- Turn off the main power switch and turn it back on.
- Remove the rear cover, and press SW2 on the FCU.

The fax unit cannot make automatic service calls in reaction to a Fax SC Code, because the fax unit cannot make fax communications in SC Code conditions.

7.2.2 SC1201

When the FCU detects an unrecoverable error in the SRAM, which requires a complete SRAM initialization, the fax unit displays this SC Code and stops. There is no way to recover from this error condition without a complete SRAM initialization (all the user and service programmed data will be erased).

The possible causes are:

- SRAM backup battery defect, or SW1 on the FCU is at the “OFF” position
- SRAM on the FCU has a physical defect
- Flash memory card or data copy tool connection was loose

7.2.3 SC1207

This is the same as SC1201 except the error location is the SRAM on the EXFUNC board.

The possible causes are:

- SRAM backup battery defect, or SW1 on the EXFUNC board is at the “OFF” position.
- SRAM on the EXFUNC has a physical defect.
- The EXFUNC connection was loose.

7.2.4 FAX SC CODE TABLE

| SC Code | Description | Suggested Action | Sys Switch 1F bit 7 = 0 | Sys Switch 1F bit 7 = 1 |
|---------|---|--|----------------------------|----------------------------|
| 1102 | Handshake error with BiCU at start-up | Initialize the fax unit. (See section 7.2.1 for the initialization procedure) | Automatic reset | SC Code display |
| 1111 | Command TX/RX error to/from the BiCU | | | |
| 1112 | Base copier's engine was reset | | | |
| 1120 | Interface module error | | | |
| 1201 | Unrecoverable FCU - SRAM error | Refer to section 7.2.2. | SC Code display | |
| 1207 | Unrecoverable EXFUNC - SRAM error | Refer to section 7.2.3. | SC Code display | |
| 1299 | Software error | Turn off and on the main switch. | Automatic reset | |
| 1301 | Original size error | Check the scanner mechanism. | | |
| 1302 | Scanner parameter error | Initialize the fax unit. | | |
| 1303 | Software error | Initialize the fax unit. | | |
| 1304 | | | | |
| 1305 | | | | |
| 1306 | | | | |
| 1308 | | | | |
| 1313 | | | | |
| 1314 | | | | |
| 1316 | | | | |
| 1318 | | | | |
| 1323 | | | | |
| 1324 | | | | |
| 1326 | | | | |
| 1328 | | | | |
| 1334 | | | | |
| 1338 | | | | |
| 1401 | Command timeout error - after scanning | Initialize the fax unit. | | |
| 1402 | Software error | Initialize the fax unit. | | |
| 1403 | | | | |
| 1404 | | | | |
| 1405 | Command timeout error - during storage | Check the connection for the FCU. | | |
| 1406 | Command timeout error - original feed out | Initialize the fax unit. | | |
| 1410 | Software error | Initialize the fax unit. | | |

A891 Point to Point Diagram (model: Stinger-C Fax unit)

